



Catalog 250-19

Maverick® II Commercial Packaged Rooftop Systems

Heating and Cooling

Models MPS 015F-017F, 020G-026G and 030F-075F

15 to 75 Tons

R-410A Refrigerant



Table of Contents

Introduction	3	MPS 026–035 Unit Dimensions	58
The HVAC Solution for Low Rise Buildings	3	MPS 026–035 Roof Curb Dimensions	61
MPS 015–050 Features and Options	4	MPS 026–035 with Energy Recovery Wheel Unit Dimensions	62
MPS 015–050 Units with Energy Recovery Wheel Features and Options	6	MPS 026–035 Units with Energy Recovery Wheel Roof Curb Dimensions	66
MPS 061–075 Features and Options	8	MPS 040–050 Unit Dimensions	67
Features and Benefits	10	040–050 Roof Curb Dimensions	70
Why Choose Daikin Applied Rooftop Systems?	10	MPS 040–050 Units with Energy Recovery Wheel Dimensions	71
Outside Air Options	14	MPS 040–050 Units with Energy Recovery Wheel Roof Curb Dimensions	73
MicroTech Unit Controls	16	MPS 061 Unit and Curb Dimensions	74
Application Considerations	22	MPS 070–075 Unit and Curb Dimensions	75
Unit Selection	27	MPS 061–075 Additional Curb Dimensions	76
Physical Data	29	MPS 061–075 Section Dimensions	77
Performance Data	33	MPS 061–075 Knockout Dimensions	79
Electric Heating Capacity	33	Weight Data	80
Hot Water Heating Capacity	33	MPS 015–050 Unit and Curb Weights	80
Gas Heating Capacity	34	MPS 015–050 Weight Distribution Percentage	81
Pressure Drops	35	MPS 015–050 Weight Distribution Locations	81
Hot Water Low/High Heat Curves	37	MPS 061–075 Unit Weights	82
Hot Water Pressure Drop Curves	42	6-Row Coil and HGRH Coil Weights	82
Supply Fan Performance	45	Fan Motor Weights	82
Dimensional Data	51	Roof Curb Weights	82
MPS 015–020 Unit Dimensions	51	Electrical Data	83
MPS 015–020 Roof Curb Dimensions	54	Power Wiring	83
MPS 015–020 with Energy Recovery Wheel Unit Dimensions	55	Supply Power Wiring	87
MPS 015–020 Units with Energy Recovery Wheel Roof Curb Dimensions	57	Data Electric Heater Data	87
		Engineering Guide Specifications	88

©2023 Daikin Applied, Minneapolis, MN. All rights reserved throughout the world. This document contains the most current product information as of this printing. Daikin Applied Americas Inc. has the right to change the information, design, and construction of the product represented within the document without prior notice. For the most up-to-date product information, please go to www.DaikinApplied.com.

™@ PreciseLine, MicroTech, SiteLine, and Daikin Applied are trademarks or registered trademarks of Daikin Applied Americas Inc. The following are trademarks or registered trademarks of their respective companies: BACnet from American Society of Heating, Refrigerating and Air-Conditioning Engineers, Inc.; Echelon, LonWorks, LonMark, and LonTalk from Echelon Corporation; Modbus from Schneider Electric; and Windows from Microsoft Corporation.

Introduction

The HVAC Solution for Low Rise Buildings

- Non-ozone depleting R-410A refrigerant
- Variable air volume (VAV) or constant volume (CV) operation
- EER meets ASHRAE 90.1 2016
- Durable, double wall construction with access doors on both sides
- Gas heat option with staged or modulating control
- Economizer with 80% to 100% exhaust
- Building pressure control with a VFD
- Factory integrated and commissioned MicroTech® DDC control system
- Daikin Applied's Open Choices™ feature provides building automation system integration using BACnet® MS/TP, BACnet IP, or LONTALK® communication protocol options
- Stainless steel sloped drain pan
- 2" prefilters with option for 4" secondary filter on sizes 15–50, and 12" secondary filters on sizes 61–75
- Airfoil fans provide non-overloading operation, better fan efficiency, and less noise
- Energy recovery wheel with unitary construction and single-point power connection

Agency Listed



MEA
265-07-E



Nomenclature (MPS 015*–050)

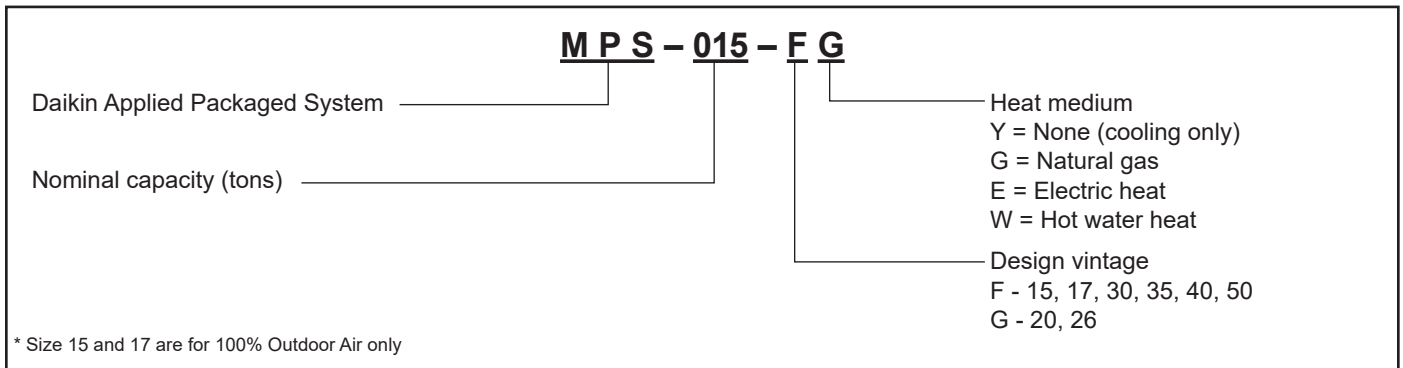

Nomenclature (MPS 061–075)

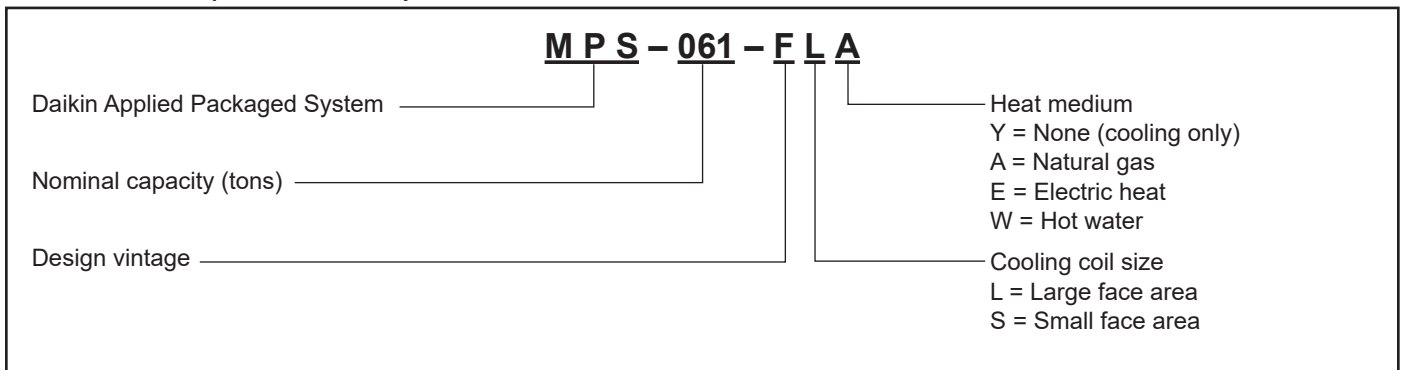

MPS 015–050 Features and Options

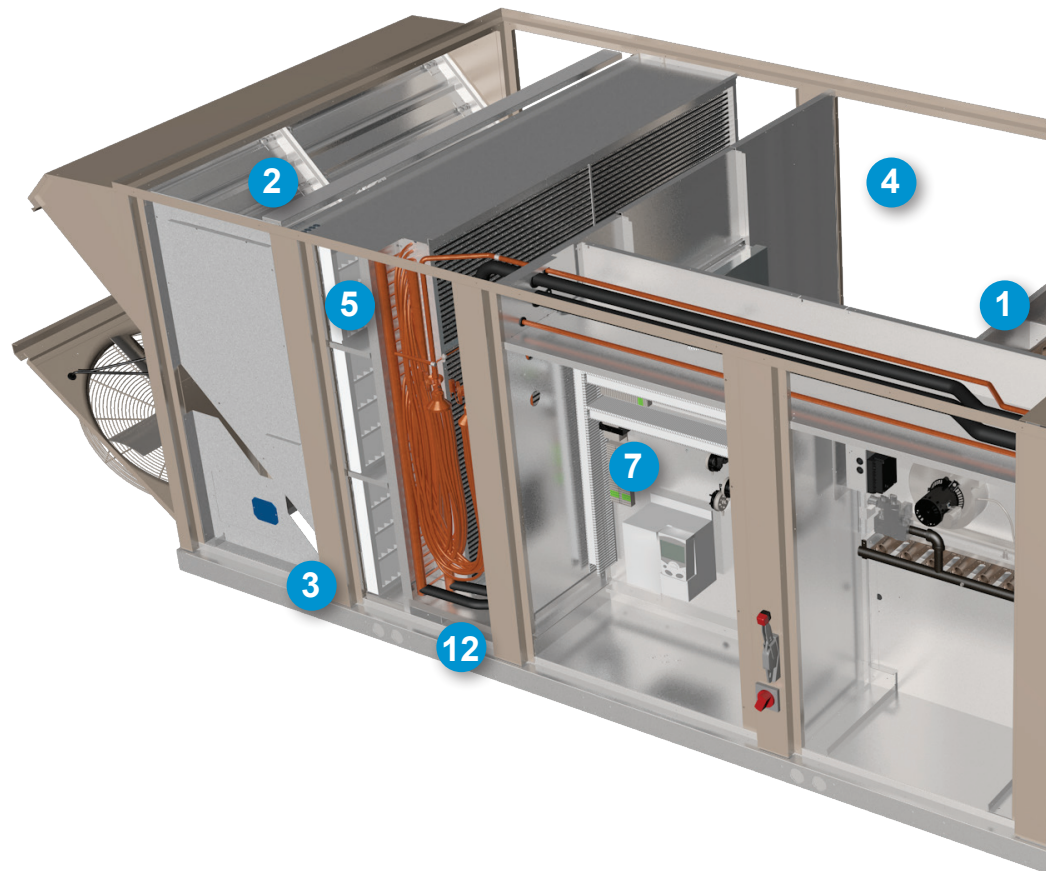

1 Airfoil plenum fan

- Energy efficient and quiet
- 1" spring isolators for superior vibration control
- Class II construction
- Premium efficiency motor is standard

2 Low leak outside air dampers

- 4 cfm/ft² to meet ASHRAE Standard 90.1 2016
- Double-wall blades
- Blade edge and jamb seals
- Outdoor Air Monitor option

3 Economizer

- DCV control for efficient VAV operation
- CO₂ control for building IAQ
- Exhaust fans with building pressure control
- Provide better building envelope airflow control which increases building operation efficiency

4 Hinged access doors

- On both sides of unit of every section for easy access to all components
- Easy open quarter-turn latches
- Double-wall construction protects insulation during maintenance

5 2 3/4" combination filter rack

- Provides more flexibility to meet building filtration requirements
- 2" MERV 8 filters shipped with unit, owner preference thereafter

6 Microchannel condenser coils

- Proven technology from the automotive industry
- Suited for R-410A operating pressures
- All aluminum design for minimal corrosion between fins, tubes, and header

7 MicroTech® unit controller

- Open Choices™ feature provides interoperability with BACnet or LonMark communications for easy integration into your building automation system of choice
- Outdoor air and humidity control logic maintains minimum fresh air intake and optimum humidity levels
- Optionally add the SiteLine™ Building Controls solution, to provide real-time data streams for benchmarking performance, monitoring system operations and implementing remote diagnostics and control

8 Durable construction

- Pre-painted exterior cabinet panels pass 1000-hour ASTM B 117 Salt Spray Test for durability
- Weather-resistant construction with capped seams and sloped top panels
- Double-wall construction protects R-4 insulation and provides wipe-clean surface

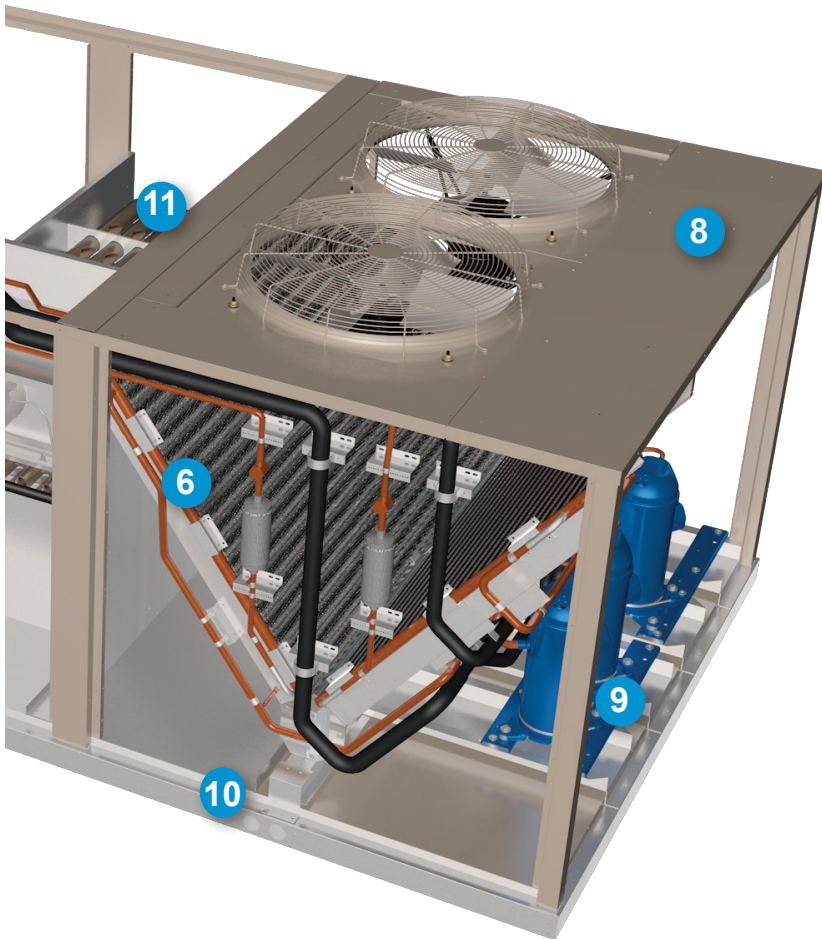

9 Fixed speed scroll compressors

- Provide maximum dependability, efficiency, and quiet operation
- 2-5 stages of capacity control for efficient DAT control

Variable speed scroll compressors

- Enhanced part load efficiency, lower operating cost
- Improved comfort, precise temperature and humidity control
- Reduced refrigerant fluctuations
- Superior acoustics at part load
- Minimized compressor cycling
- Reduced wear of compressors

10 R-410A refrigerant

- No ozone depletion potential or phase-out date
- Greater than 10.0 EER, meets ASHRAE 90.1 2016 energy requirements
- Dual refrigerant circuits provide redundancy for high unit reliability

11 Gas heat

- Tubular heat exchanger for maximum heat transfer
- Four-stage capacity control
- Optional 4-to-1 modulation control on low heat
- Optional 8-to-1 modulation control on high heat

Optional electric heat

- 4-stage control
- Operational safeties
- High-limit temperature switch
- Single point power

Optional hot water heat

- Low and high capacity options
- DDC control ready with 0–10 volt wiring harness
- Vestibule for field installed control valve package

12 Stainless steel, double-sloped drain pan

- Prevents corrosion
- Avoids standing water for high IAQ

MPS 015–050 Units with Energy Recovery Wheel Features and Options

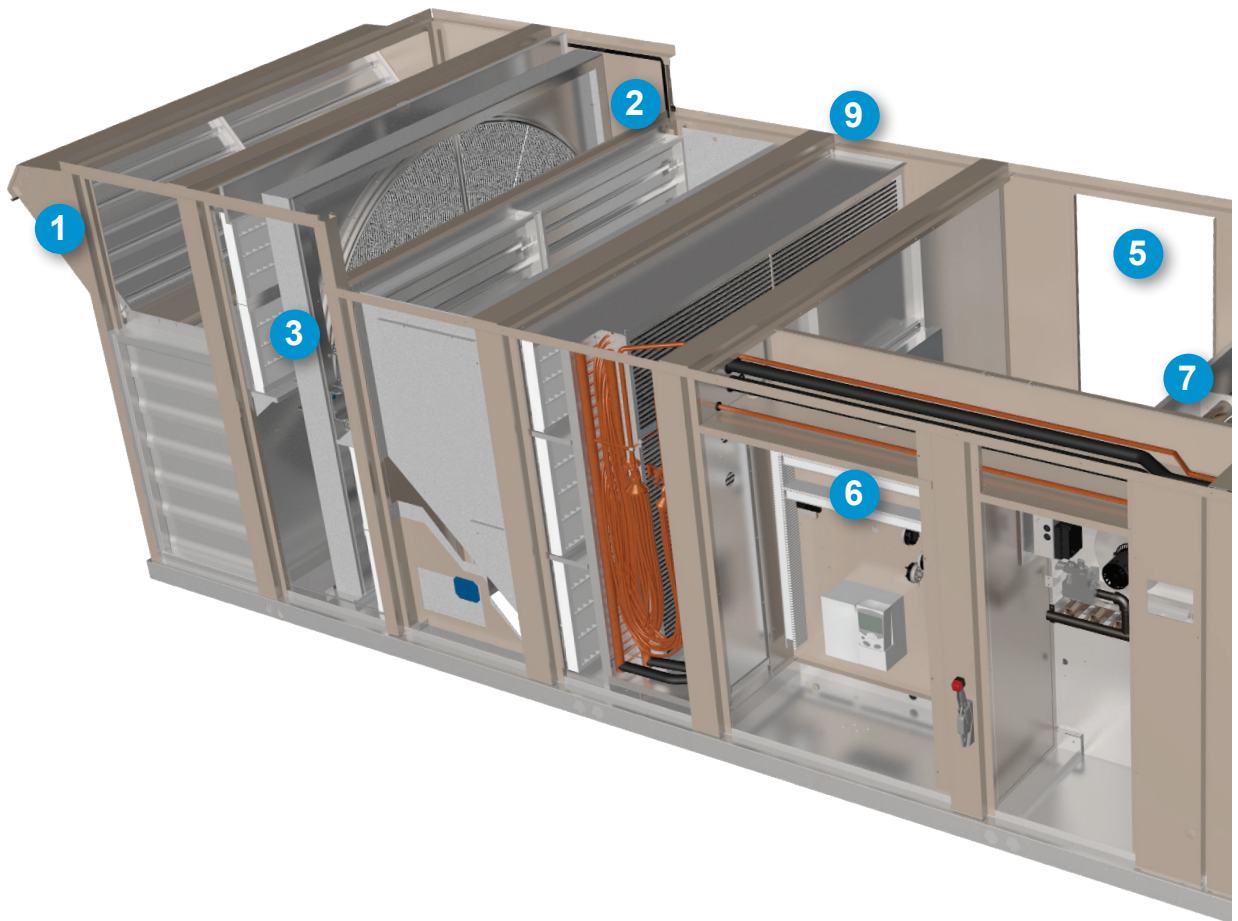

1 Exhaust fans with building pressure control

- Provide better building operations, higher customer satisfaction

2 Optional energy recovery wheel

- Meets ASHRAE Standard 90.1 2016
- Factory installed
- Single point power
- 2" MERV 7 filters to minimize wheel cleaning and maintenance

3 2" Combination filter rack

- Provides more flexibility to meet building filtration requirements
- 2" MERV 8 filters shipped with unit, owner preference at building occupancy

4 Fixed speed scroll compressors

- Provide maximum dependability, efficiency and quiet operation

Variable speed scroll compressors

- Enhanced part load efficiency, lower operating cost
- Improved comfort, precise temperature and humidity control
- Reduced refrigerant fluctuations
- Superior acoustics at part load
- Minimized compressor cycling
- Reduced wear of compressors

5 Hinged access doors

- On both sides of unit for easy access to all components
- Easy open, quarter-turn latches
- Double-wall construction protects insulation during maintenance

6 MicroTech® unit controller

- Open Choices™ feature provides interoperability with BACnet or LonWorks communications for easy integration into your building automation system of choice
- Outdoor air and humidity control logic maintains minimum fresh air intake and optimum humidity levels
- Optionally add the SiteLine™ Building Controls solution, to provide real-time data streams for benchmarking performance, monitoring system operations and implementing remote diagnostics and control

7 Airfoil plenum fan

- Energy efficient and quiet
- 1" spring isolators for superior vibration control
- Premium efficiency motor is standard
- Vibration transmissibility of less than 5%

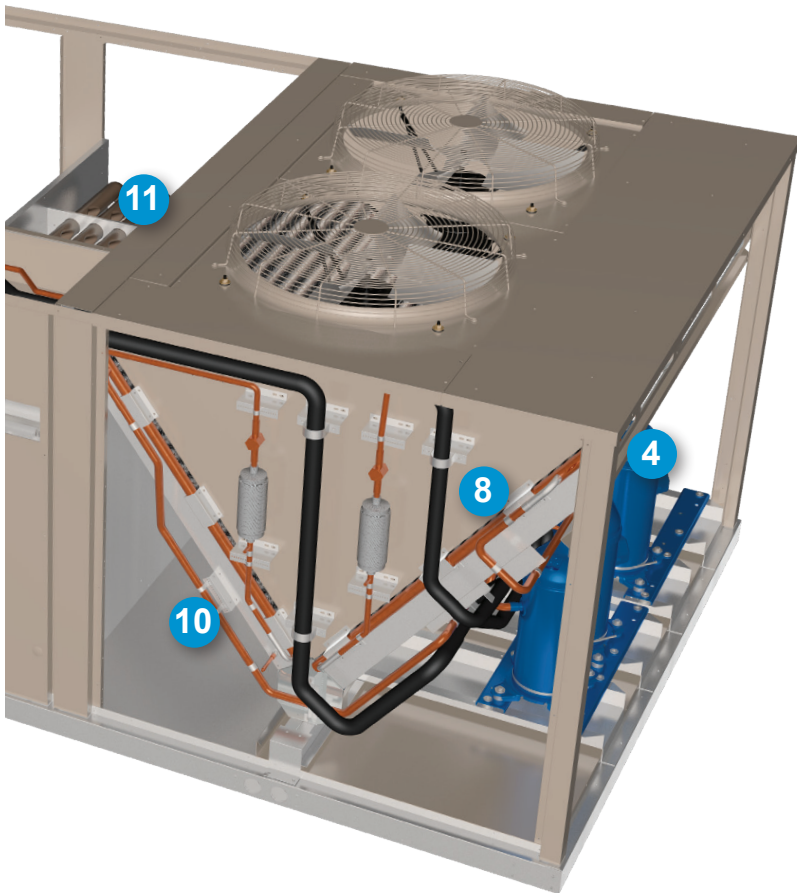

8 Microchannel condenser coils

- Proven technology from the automotive industry
- Suited for R-410A
- All aluminum design
- Minimal corrosion between fins, tubes and header
- LEED® credit for enhanced refrigeration management

9 Durable construction

- Pre-painted exterior cabinet panels pass 1000-hour ASTM B 117 Salt Spray Test for durability
- Double-wall construction protects insulation and provides wipe-clean surface

10 R-410A refrigerant

- No ozone depletion potential or phase-out date
- EER per ASHRAE 90.1 2016
- Dual refrigerant circuits provide redundancy for high unit reliability

11 Gas heat

- Tubular heat exchanger
- Aluminized steel or optional stainless steel tubes
- Staged or modulating control
 - 4:1 on low heat
 - 8:1 on high heat

Optional electric heat

- 4-stage control
- Operational safeties
- High-limit temperature switch
- Single point power connection

Optional hot water heat

- Low and high capacity options
- DDC control ready with 0–10 volt wiring harness for water control valve
- Vestibule for field installed control valve package

MPS 061–075 Features and Options

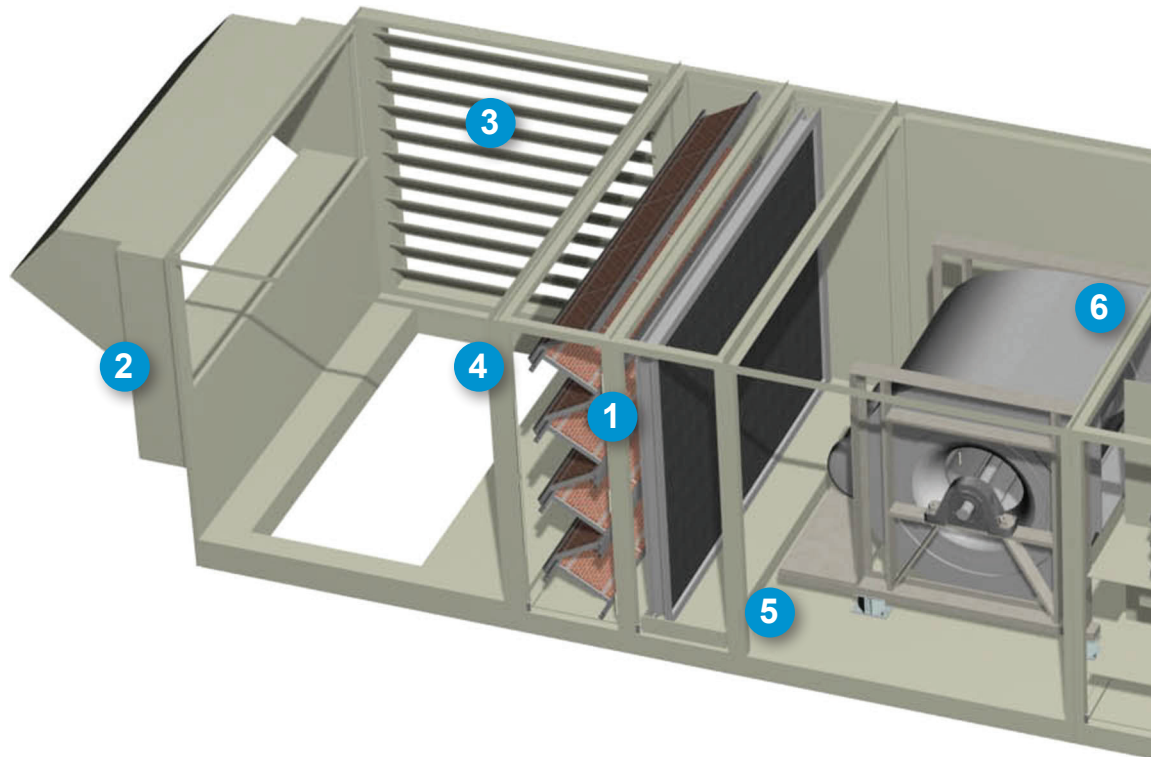

1 Cartridge filters with prefilters

- 2", 30% MERV 8 angular (shown)
- 6", 60% MERV 11
- 12", 90% MERV 14

2 Economizer

- DCV control for efficient VAV operation

3 Low leak outside air dampers

- Double-wall blades
- Blade edge and jamb seals

4 Exhaust fans with building pressure control

- Provide better building envelope airflow control which increases building operation efficiency

5 Stainless steel, double-sloped drain pan

- Prevents corrosion
- Avoids standing water for high IAQ

6 Airfoil plenum fan (DWDI shown)

- Energy efficient and quiet
- 2" seismic spring isolators for superior vibration control
- Class II construction
- Premium efficiency motor is standard

7 MicroTech unit controller

- Open Choices feature provides interoperability with BACnet or LonMark communications for easy integration into your building automation system of choice
- Outdoor air and humidity control logic maintains minimum fresh air intake and optimum humidity levels
- Optionally add the SiteLine™ Building Controls solution, to provide real-time data streams for benchmarking performance, monitoring system operations and implementing remote diagnostics and control

8 Hinged access doors

- On both sides of unit of every section for easy access to all components
- Easy open, single point latch
- Double-wall construction protects insulation during maintenance

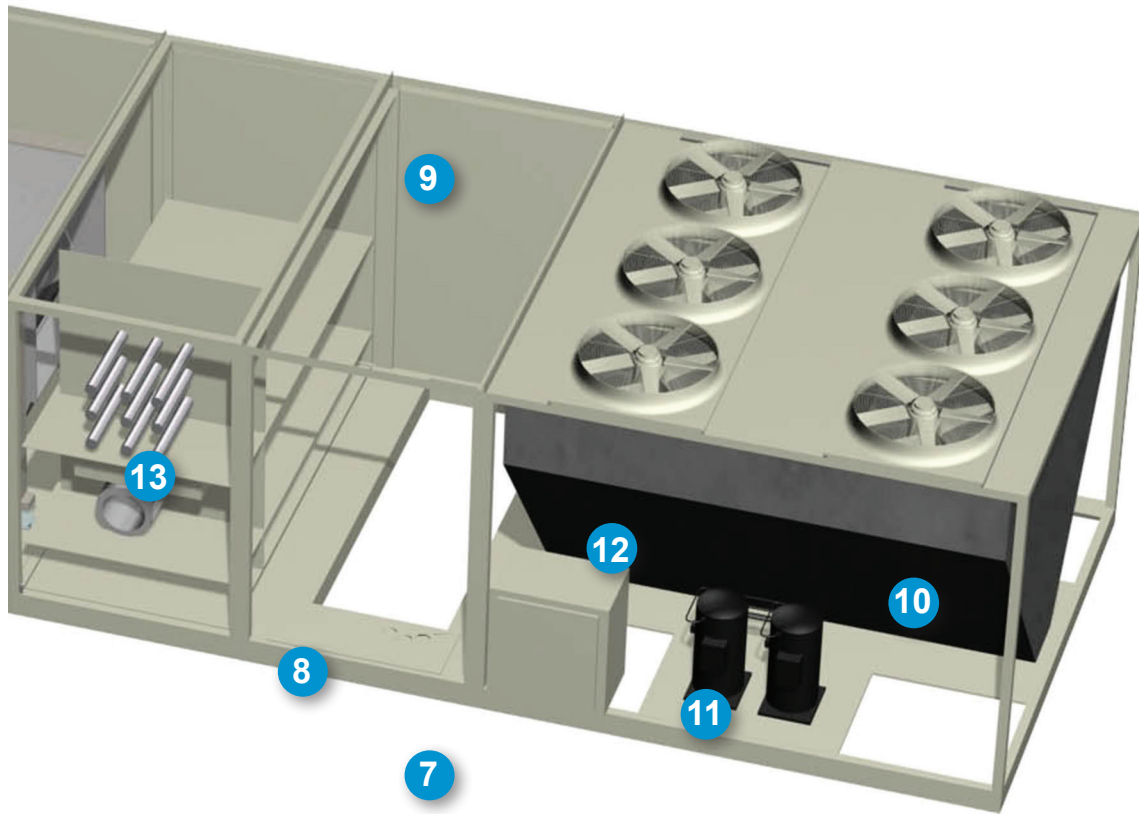

9 Durable construction

- Pre-painted exterior cabinet panels pass 1000-hour ASTM B 117 Salt Spray Test for durability
- Weather-resistant construction with capped seams and sloped top panels
- Double-wall construction protects R-6.5 insulation and provides wipe-clean surface

10 Microchannel condenser coils

- Proven technology from the automotive industry
- Suited for R-410A high operating pressures
- All aluminum design
- Minimal corrosion between fins, tubes, and header

11 Scroll compressors

- Provide maximum dependability, efficiency, and quiet operation
- 4-6 stages of capacity control for efficient DAT control
- Discharge unit liquid line isolation valves standard

12 R-410A refrigerant

- No ozone depletion potential or phase-out date
- Meets ASHRAE 90.1 2016 energy requirements (except the 75)
- Dual refrigerant circuits provide redundancy for high unit reliability

13 Gas heat

- Drum and tube heat exchanger for maximum heat transfer
- 3-to-1 modulation control on low heat
- Stainless steel heat exchanger

Optional electric heat

- DDC with 4-stage control
- Operational safeties
- High-limit temperature switch
- Single point power

Optional hot water heat

- Low and high capacity options

Features and Benefits

Why Choose Daikin Applied Rooftop Systems?

Maverick II rooftop systems are the HVAC solution for low rise building projects. Available with cooling capacities from 15 to 75 tons and energy efficiencies of 10.0 EER and higher.

Maverick II systems are built to perform, with features and options that provide for lower installed costs, high energy efficiency, good indoor air quality, quiet operation, low cost maintenance and service, and longevity. Completed systems are factory tested and shipped with a cETLus Safety Listing.

High Efficiencies and Competitively Priced

Daikin Applied offers a complete line of R-410A rooftop systems that meet the efficiencies of ASHRAE 90.1 2016

Variable Speed Scroll Compressors

Daikin Applied units with variable speed scroll compressors are engineered with both fixed speed and variable speed scroll compressors in such a way that unit delivers only the required energy to satisfy space conditions and provides you with exceptional energy savings. It improves comfort through precise temperature and humidity control. Variable speed scroll compressors enhanced energy efficiency and are capable of providing modulation down to 20%, eliminates excessive compressor cycling and reduces the wear on compressors. It also provides superior acoustics at part load capacity.

Variable speed scroll compressors on Daikin Applied Maverick II rooftops are provided with Internal Permanent Magnet (IPM) motors. Compressors are designed to vary capacity by modulating the speed of the scroll set. The speed ratio for IPM motor compressors is 4:1.

Figure 2: MPS 020–050 Example

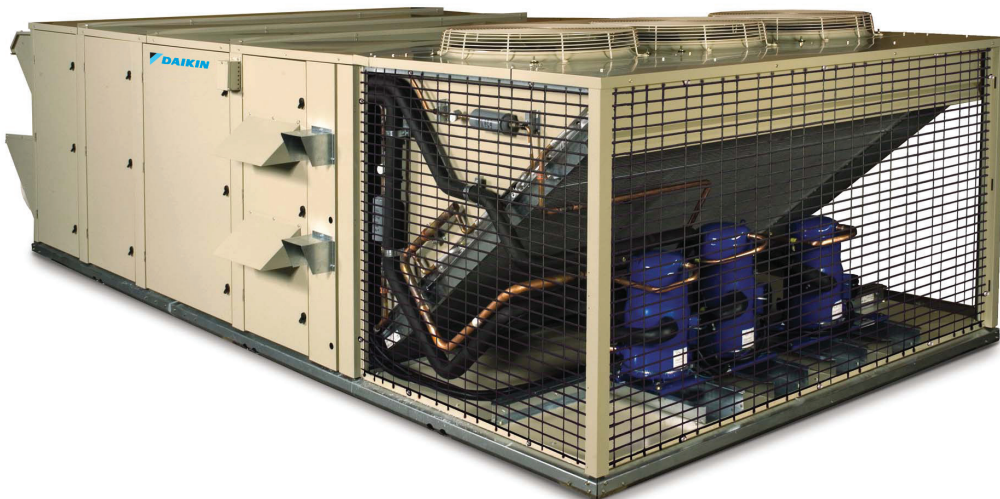

Easy, Low Cost Installation, Maintenance and Service

Maverick II units arrive at the job site as a complete package, including fully tested controls. This eliminates the need for expensive field assembly, refrigerant piping, and control installation. Hinged access doors on both sides of the unit put all components within easy reach for maintenance and service personnel. This promotes regular maintenance for peak system performance.

Daikin Applied R-410A rooftop systems use all-aluminum, microchannel condenser coils, which help reduce galvanic corrosion, making them more resistant to corrosion in any environment. However, if the unit is located in a corrosive environment, such as near the sea coast or industrial fumes, then optional coated condenser coils are required.

Figure 1: Microchannel Condenser Coils

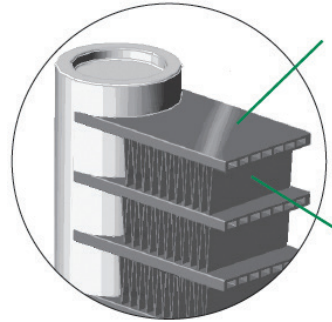

Flat aluminum tubes with many small flow channels increase fluid-to-tube heat transfer and reduce refrigerant charge requirements.

Aluminum fins brazed between adjoining tubes protect the fins from surface damage, which can inhibit cooling

MicroTech® controls are easily accessed for equipment diagnostics and adjustments via a keypad/display on the unit. Our Open Choices feature provides interoperability with building automation systems (BAS), including those using the BACnet and LonTalk communication protocols. The result is easy access to all unit operating data from a central control station.

Unit Construction

- Nominal unit cooling capacities from 15 to 75 tons
- Pre-painted exterior surfaces that withstand a minimum 1000-hour salt spray test per ASTM B117
- Double-wall hinged access doors on both sides of the unit
- Heavy-gauge, galvanized steel unit base with a formed recess to seat on roof curb gasket and provide positive weather-tight seal
- Rigging brackets integral to the unit base
- Double-wall construction to protect the insulation, enhance performance, and satisfy IAQ requirements
- Fully insulated base and condenser fans

Controls

- Integrated advanced MicroTech DDC controls with unit-mounted interface featuring a 4-line, 20-character English display for fast equipment diagnostics and adjustments, providing the best possible comfort to the space while saving energy and money
- Controls factory installed and commissioned prior to shipment for fast start-up
- Open Choices feature allows interoperability with a BAS, including those using BACnet and LonTalk communication protocols for integrating into Building Automation Services

Figure 3: MicroTech Unit Controller

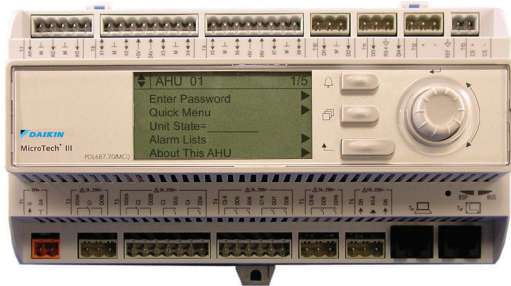
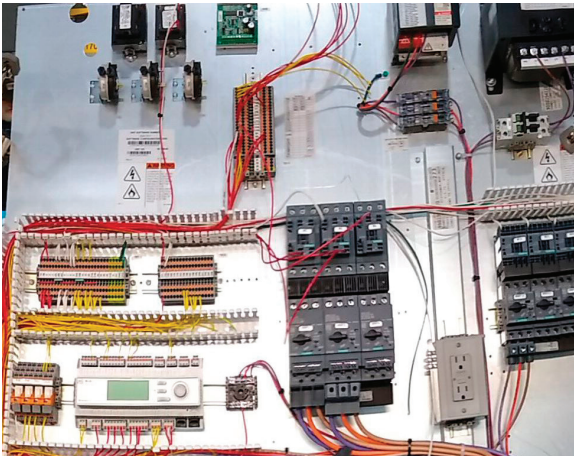

Figure 4: Control Panel Section (MPS 015–050)



Variable Air Volume Control

- Factory mounted energy saving variable frequency drive (VFD) fan speed control
- All VFDs are factory installed and tested
- To manage building static pressure, the exhaust fans have an option for being controlled by a VFD
- MicroTech controls provide advanced duct and building static pressure control and equipment diagnostics capability

Figure 5: Variable Frequency Drives



Electrical

- Units are completely wired and tested at the factory to provide faster commissioning and start-up
- Wiring complies with NEC requirements and all applicable UL standards
- All units have a minimum short circuit current rating of 10,000 amps
- For ease of use, wiring and electrical components are number coded and labeled according to the electrical diagram
- Units have a 120 V GFI convenience receptacle. The independent power supply for the receptacle is field supplied
- An optional unit powered 120 V convenience receptacle, complete with factory mounted transformer, disconnect switch, and primary and secondary overload protection, eliminates the need to pull a separate 120 V power source
- Supply air fan, compressor, and condenser fan motors branch circuits have individual short circuit protection
- A single point power connection with power block is standard
- The optional unit-mounted disconnect includes a service handle on the exterior of the unit
- Electrical power feeds inside the perimeter roof curb through factory provided knockouts located in the bottom of the main control panel

Supply Fan Section

- Airfoil blade fans provide superior energy performance and quiet operation
- Class II construction
- Concentric locking bearing
- Minimum, standard 1" seismic spring isolation reduces noise transmission into the space
- Each fan assembly is dynamically trimmed balanced at the factory
- A neoprene gasket isolates the fan housing and eliminates vibration transmission to the fan bulkhead
- Solid steel fan shafts rotate in 200,000 hour regreasable pillow block ball bearings, providing years of reliable operation
- All fan and motor assemblies are isolated from the main unit on 1" deflection spring mounts (2" deflection on 61–75 ton units)
- All fan drives have fixed pitch sheaves as standard

Figure 6: Fan Section (MPS 015–050)



Figure 7: Gas Heat Section (MPS 015–050)

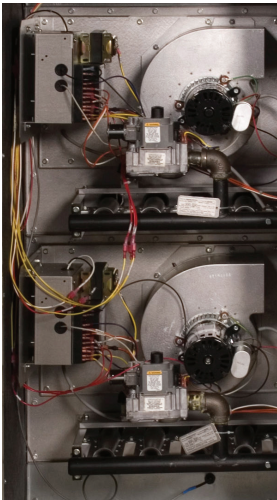

Gas Heat Option

- Natural gas heating is provided with modular heat exchangers
- Optional stainless steel heat exchanger (standard on 61–75 ton units) and optional modulating gas heat with turndowns as high as 8:1, save energy and supply greater comfort to the space
- All gas burners exceed ASHRAE Standard 90.1 efficiency requirement of 78% for low fire and 80% for high fire
- Gas burners are UL listed with the complete furnace assembly cETLus listed
- All burner assemblies are factory tested and adjusted prior to shipment.
- 15–50 ton unit heat exchangers are air induced draft tubular design with in-shot burner manifolds
- Low heat option has one module with two stages of heating capacity
 - High heat option has two modules with four stages of heating capacity control
 - 61–75 ton unit heat exchangers are a forced draft drum and tube design
- Fuel lines may be conveniently routed through the curb or the burner vestibule
- Heating control is fully integrated into the unit's MicroTech control system
- Optional field installed LP kits are available for staged heating control only

Figure 8: Gas Heat (MPS 061–075)

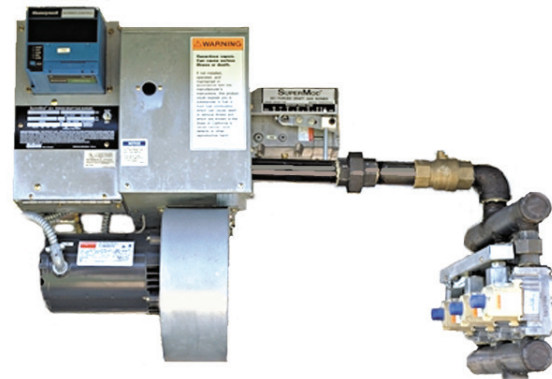

Energy Recovery Wheel

- Optional energy recovery wheel for increase efficiency for conditioning minimum outdoor air
- Unitary design for installation/rigging cost savings
- Single point power connection for decreased installation cost
- Slide-out wheel cassette & track for easy maintenance and cleaning
- Bypass dampers for increased efficiency during economizer operation
- Integrated unit control for control coordination between rooftop unit and wheel that controls the wheel speed
- Leaving wheel temperature sensors for wheel operation monitoring
- Integrated unit control with optimum leaving wheel temperature control to prevent over-heating the outdoor air
- Defrost options including ON/OFF control, Start/Stop and VFD speed modulation.

Figure 9: Energy Recovery Wheel

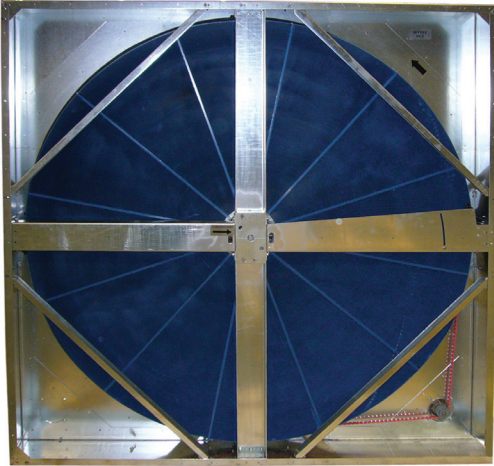

Controls and Wiring

Drive Motor

The enthalpy wheel comes with a constant speed, standard drive motor.

Frost Protection Option

The frost protection option includes the following:

- VFD to vary the speed of the energy recovery wheel (ERW)
- MicroTech controls and sensors

Frosting can occur when EA is saturated and OAT is below 32°F (Figure 10). MicroTech senses the RA temperature and humidity, as well at OAT, and determines if frost can occur. If so, the wheel is slowed down so that the wheel LAT is not saturated.

Frost may not occur on many cold climate applications

- If the energy recovery wheel only operates during day time hours, then the point #1 OAT is warmer than the ASHRAE designed winter temperatures
- If no humidification is provided, then the point #2 space relative humidity is probably 20% or lower

Figure 10: Frost protection psychrometric chart

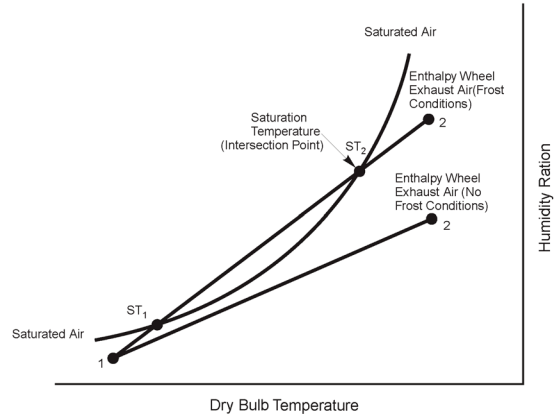

Energy Recovery Bypass Damper Control

When a unit is equipped with a 0-100% modulating economizer, the energy recovery option includes a set of bypass dampers that allow air to bypass the energy recovery wheel when the wheel is not operating. The dampers are driven closed for 2 minutes whenever the energy recovery wheel is turned on, forcing the entering and leaving air to go through the wheel. When the outdoor dampers are driven more than 3% above the Minimum Outdoor Damper Position SetPoint (as when the unit enters the Economizer operating state) the wheel is shut off and the bypass dampers are driven open allowing the entering and leaving air to bypass the wheel.

Hot Water Heat Option

- 1 and 2-row, low and high output options
- Fully cased coil
- Factory installed coil vent and drain
- Piping vestibule for field installed piping control package
- DDC control ready with 0–10 volt wiring harness
- Optional valve package on size 61–75

Electric Heat Option

- Low, medium, and high kW furnace options for matching the requirements of any project
- 4 stages of DDC control
- Single point power connection eliminates the need to pull multiple power connections
- Operational safeties
- High-limit temperature switch
- Individual coil fusing

Figure 11: Electric Heat Section

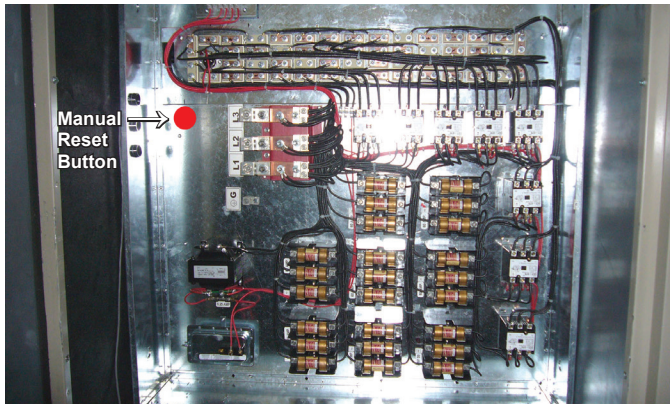

Modulating Hot Gas Reheat Option

- All aluminum coil construction eliminates corrosion and provides better heat transfer
- Controls leaving air temperature and leaving air dew point
- Low volume microchannel coil eliminates the need for refrigerant receivers
- By over-cooling the conditioned air, excessive humidity is reduced to prevent mold growth and sick building syndrome
- Modulating control provides precise temperature reheat control to keep conditioned space better satisfied

Outside Air Options

Maverick II units are available with a 0% to 30% outdoor air damper or a 0% to 100% economizer. All dampers are low-leak with blade and side seals. Leakage rates are only 1.5 cfm/ft² of the damper area at 1" differential pressure.

0% to 30% Outside Air Option

(N/A on 015 – 017 Sizes)

- Includes return air plenum and 0% to 30% outside air intake hood with motorized dampers to minimize leakage during off cycles
- Damper is field adjusted to a fixed open position that is easily set using the MicroTech keypad, allowing for a balance between IAQ and energy savings

0% to 100% Economizer Option

- A fully functional modulating economizer takes advantage of free cooling days
- Includes return air plenum with back or bottom opening, exhaust air relief dampers and low leak economizer dampers to minimize leakage during off cycles
- Economizer control is fully integrated into the unit's MicroTech control system and features spring-return actuator, adjustable minimum outside air set point and adjustable changeover
- Dry bulb economizer changeover control is standard. Optional comparative enthalpy control provides the most economical amount of outside air for "free" cooling
- Barometric relief dampers are standard for exhaust control

0% to 100% Outdoor Air (OA) Option

- Unit can be equipped with a 100% OA damper
- Damper is fully modulating for field adjustment to required air flow at the installation site
- Damper is actuated to minimize leakage during off cycles

Prop Exhaust Fans

- MicroTech controls provide staged capacity control as standard
- MicroTech controls can provide an optional VFD control for building static pressure control. The building pressure transducer is included in the control panel
- Building static pressure control is important in minimizing exfiltration, energy consumption, and preventing mold growth

Cooling Coil/Drain Pan Section

- Evaporator coils with enhanced copper tubing and aluminum fins, provide high efficiencies at full and part load operating conditions
- All evaporator coils feature interlaced circuiting to keep the full face of the coil active and eliminate air temperature stratification, allowing the cooling coil maximum humidity control
- Construction will include stainless steel drain pans to eliminate corrosion
- Drain pan is sloped 1/8"/ft per the requirements of ASHRAE, eliminating standing water and preventing bacteria growth

Ventilation Control

Daikin Applied Rooftops comply with ASHRAE 62.1-2000

- Standard Maverick II controls allow the balancer to comply with ASHRAE 62.1-2000 by adjusting minimum outdoor air damper positions to provide ventilation air at design airflow
- For VAV applications, MicroTech automatically resets the minimum damper position to compensate for reduced SAF speed
- The outdoor air monitor option eliminates the need for the balancer to adjust the minimum position and directly measures outdoor air to provide more accurate ventilation control

Size 015–050 optional OA Monitor features and benefits

- Directly measure and control outdoor ventilation air down to airflow as low as 15 cfm per ton in order to improve IAQ
 - Down to 350 cfm on Maverick II 15–20 ton units
 - Down to 600 cfm on Maverick II 26–35 ton units
 - Down to 800 cfm on Maverick II 40–50 ton units
- Thermal dispersion technology, NIST traceable flow standards and laboratory testing of the entire assembly allows the ventilation control accuracy to +/-15%
- Complies with the measurement portion of the Outdoor Air Delivery Monitoring LEED® Point EQc1
- This option is factory-installed, calibrated and tested to reduce installation costs and risks. The user must only enter the outdoor airflow set point

Application

- The outdoor air monitor measures the airflow and sends the appropriate analog signal to the MicroTech controller which in turn modulates the outdoor air damper to maintain proper ventilation levels. The desired outdoor airflow set point is directly entered at the MicroTech controller, keypad or read from the BAS
- Outdoor air cfm can be displayed on the MicroTech controller, as well as the outdoor air monitor and the MicroTech writes this value to the BAS
- All BAS communication is done through the optional, MicroTech, Lon or BACnet communications cards

Figure 12: Outdoor Air Monitor



OA Monitor

OA Controller

Condensing Section

- Open design permits unrestricted condenser airflow, access to compressors, and refrigeration components and piping
- Condenser coil hail protection is integral with the design
- High efficiency scroll compressors
- Each refrigerant circuit is furnished with an accessible filter drier, high pressure switch, low pressure switch, and expansion valve
- All units feature dual refrigeration circuits for redundancy and efficient capacity control
- Vertical air discharge minimizes condenser fan noise
- Three-phase condenser fan motors eliminate reverse rotation failures
- A vandal protection screen is standard on 15–50 ton units and optional on 61–75 ton units

Figure 13: Condensing Section (MPS 015–050)



Filter Section

- Combination 2" – 4" filter tracks and 2" MERV 8 filters are provided for 15–50 ton units. Single or combination tracks may be used for the building's filtration needs
- 61–75 ton units are available with 2", 30% MERV 8 angular filters, 6", 60% MERV 11 cartridge filters, or 12", 90% MERV 14 filters. MERV 11 and MERV 14 filters also include MERV 8 prefilters
- Multiple access doors allow easy filter changes from either side of the unit

Roof Curbs

- Constructed in accordance with NRCA guidelines with 12-gauge galvanized steel
- Fits inside the unit base. 15–50 ton units use a full perimeter curb. 61–75 ton units use an air handler curb with an island rail for the condensing unit
- Gasket seals between the curb and the unit

MicroTech Unit Controls

Superior Performance and Easy Integration

Each Maverick II rooftop unit is equipped with a complete MicroTech unit control system that is pre-engineered and factory tested prior to shipment. Its features include:

- Stable, efficient temperature and static pressure control
- Comprehensive diagnostics
- Alarm monitoring
- Alarm-specific component shutdown if critical equipment conditions occur

The MicroTech control system comes standard with a user interface, providing system operators with superior access to temperatures, pressures, operating states, alarm messages, control parameters, and schedules. All messages display in English text. Password protection is included to protect against unauthorized or accidental set point or parameter changes.

MicroTech control system components include:

- DDC controller with keypad/display user interface
- Ductwork or building pressure transducers
- Unit-mounted temperature sensors
- Field installed zone temperature sensor packages
- Enthalpy sensors/controllers
- Field installed CO₂ sensors

Open Choices™ Feature

MicroTech unit control systems are factory configured for either stand-alone operation or for incorporation into an independent building automation systems (BAS) through Daikin Applied's Open Choices feature. This feature provides building automation system integration using BACnet MS/TP, BACnet IP, or LonTalk communication protocol options.

BACnet communications conform to the BACnet Standard, ANSI/ASHRAE Standard 135-2004, and are supported by a protocol implementation conformance statement (PICS).

LonTalk communications are in accordance with either the Discharge Air Controller (DAC) or Space Comfort Controller (SCC) profiles and are LONMARK 3.4 certified.

The building automation system can interact with one or more rooftop unit controllers in any of the following ways:

- Sets the unit's operating and occupancy modes
- Monitors all controller inputs, outputs, set points, parameters, and alarms
- Sets controller set points and parameters
- Clears alarms
- Resets the cooling discharge air temperature set points (VAV units)
- Resets the duct static pressure set point (VAV units)
- Sets the heat/cool changeover temperature
- Sets the representative zone temperature (CAV-ZTC units)

DDC Unit Controller

The DDC controller contains a microprocessor that is preprogrammed with the software necessary to control the unit. This can keep schedules, set points and parameters from being lost, even during a 48-hour power outage. The microprocessor board processes system input data and then determines and controls output responses.

Communication Modules

Field installed communication modules provide the means to configure MicroTech unit controls for interoperability with an independent BAS using Daikin Applied's innovative Open Choices feature. Communication modules are available to support BACnet MS/TP, BACnet/IP, LONMARK and Daikin Applied DIII communication protocols.



SiteLine™ Building Controls

Daikin Applied makes building automation simpler, more effective and easier to scale than any other controls solution on the market today.

Whether you're overseeing a complex HVAC ecosystem of equipment and buildings or monitoring standalone units, SiteLine Building Controls and Service Solutions will help you create comfortable and sustainable environments where tenants work and live.

Daikin Applied's scalable, cloud-based building automation systems (BAS) instantly and easily optimize the performance of any HVAC ecosystem—including other makes and existing building systems. Plus, our real-time analytics provide effortless insight and enable optimization for energy, indoor air quality (IAQ) and sustainability.

Benefits

- Easy installation with out-of-the box functionality for both new and retrofit applications.
- Simple operation that brings insight to system performance and is intuitive to manage.
- Low upfront costs that enable you to work with other equipment systems
- Scalable solutions for both standalone equipment and building systems.
- Advanced security that protects customer data.

Figure 14: VRV/DOAS System

VRV + Dedicated Outside Air System (DOAS)

The Daikin MPS can be directly connected to a Daikin, VRV, DIII network. A DIII gateway communication card is shipped loose for field installation or factory-installed in the MPS control panel.

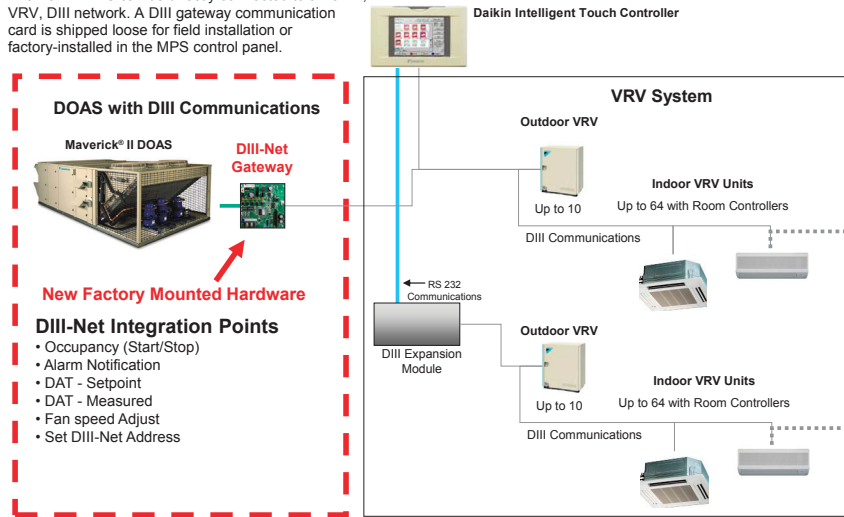

Figure 15: SiteLine Building Controls Dashboards

Customer Dashboard

The Customer Dashboard provides a comprehensive overview of building performance. Key sections include:

- Building Status:** Shows an aerial view of the building and an **Energy Star Score** of 100 (Target Score: 75).
- My Usage Comparison:** Displays energy, water, and fuel usage, all showing significant savings compared to last year (e.g., Energy is 4.6% lower).
- HVAC Summary:** Shows unit status (No Alarm), maintenance needs (Not Needed), and live power usage (0.45% savings).
- Comfort Index:** A 95% score is shown, indicating high occupant comfort.
- Weather:** Real-time weather data for Plymouth, MN, including temperature, wind, and humidity.
- Financial Summary:** A bar chart shows monthly savings (USD) from January to June, with a total payback amount of \$5040.00.
- Building Info:** Details such as Site Name (Daikin Corporate Office), Unit (RTU-2), and Site Address.
- As of the Last 30 Days:** A graph shows relative humidity (%) over time, with a 95% Comfort Index score.

Technician Dashboard

The Technician Dashboard provides detailed information for a specific unit, **Unit Tag - RTU-4**. Key features include:

- Unit Overview:** Shows **Alarm Cleared / No Active Alarms** and provides access to the **Alarm Log**.
- Overview Live Data:**
 - Unit Overview: Discharge Air Temperature (72.7°F), Occupancy Mode (Auto), Occupancy Status (Occ), Return Air Temperature (69.9°F).
 - Heating, Economizer, Cooling, and Power Usage sections.
- Unit Diagram:** A 3D model of the RTU-4 unit with numbered callouts (1-7) for maintenance access points:
 - ERV, Economizer & Filter Access
 - Coil Access Panel
 - Supply Fan & Gas Heat Access
 - Gas Connection
 - Condensate
 - Control Panel
 - Inverter Panel
- Upcoming Maintenance:** RTU-4 is scheduled for weekly, bi-monthly, monthly, quarterly, and annual maintenance.

Keypad/Display

The keypad/display provides a user interface with the main controller and has easy-to-use keys and control knob used for navigation and entering changes. The display is a 4-line by 20 character format with clear English display messages. All operating conditions, system alarms, control parameters and schedules can be monitored from the keypad/display. If the correct password has been entered, any adjustable parameter or schedule can be modified from the keypad.

Figure 16: Keypad/Display Interface

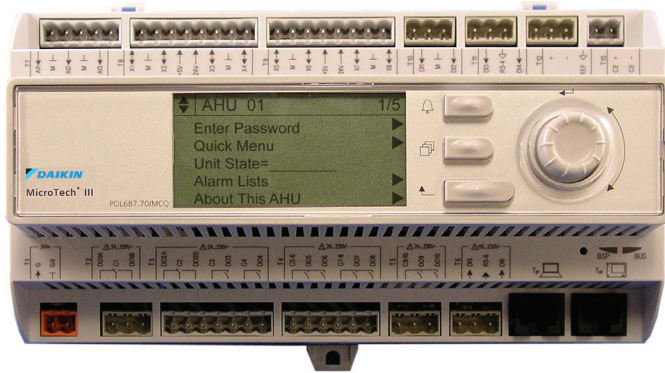

Unit Sensors

Temperature and Enthalpy Sensors

The return, discharge, and outside air temperature sensors are factory installed. The zone temperature sensor package can be ordered as a field installed option.

Zone Temperature Sensors

Two optional zone temperature sensors are available:

1. Zone sensor with tenant override.
2. Zone sensor with tenant override and remote set point adjustment.

Timed tenant override is a standard MicroTech control feature.

Zone sensors are required for the controller's space reset of supply air set point and night setback features. All zone sensors are field installed with field wiring terminated at the unit controller.

The optional comparative enthalpy control economizer package is provided with the enthalpy sensor for the return air and outside air factory installed.

Static Pressure Transducers

When the Daikin Applied Packaged System is ordered with the VAV option, the duct static pressure transducer is factory installed as standard. The units can also have an exhaust fan option. The exhaust fans on VAV units are controlled by the building static pressure control package. The exhaust fans on CAV units are controlled by either the building static pressure control package as mentioned above, or they are controlled by the DDC program based on the outside air damper position. The static pressure transducers are factory installed when building static pressure control is ordered. The installation and routing of the field-supplied sampling tubes is done at the time of the unit installation.

Stand-Alone Controller Features

MicroTech rooftop unit controls include all of the essential features required to make them capable of independent and stand-alone operation.

Auto/Manual Operation Selection

Automatic or manual operation can be controlled at the keypad. The keypad provides a variety of occupancy and auto/manual control mode selections available to the operator:

Occupancy Modes	Control Modes
Auto	Off Manual
Occupied	Auto or Heat/Cool
Unoccupied	Cool Only
Bypass (tenant override)	Heat Only
	Fan Only

Cooling and Heating Lockout Control

All unit controls include separate keypad-programmable set points for locking out mechanical cooling and heating. Mechanical cooling is locked out when the outdoor temperature is below the cooling lockout set point. Heating is locked out when the outdoor temperature is above the heating lockout set point. This feature can save energy cost by eliminating unnecessary heating and cooling during periods when the outdoor air temperature is mild.

Night/Unoccupied Setback

When one of the zone temperature sensors is connected to them unit controller, night setback heating control and night setback cooling control are available. Separate, keypad-programmable, night heating and night cooling set points are used to start the unit when necessary. After the unit starts, night setback control is similar to normal occupied control except that the minimum outside air damper position is set to zero. If the outside air is suitable for free cooling, it is used during night setback operation.

Internal Time Clock

An internal time clock is included in the MicroTech unit controller. Current date and time can be quickly and easily set at the user interface keypad.

Internal Schedule

Seven daily schedules and holiday schedules can be entered at the keypad of all unit controllers. For each of these eight schedules, one start and one stop time can be entered. Up to 16 holiday periods of any duration can be designated. The unit will automatically run according to the holiday schedule on the holiday dates.

In lieu of its internal schedule, the unit can be operated according to a network schedule from a BAS.

External Time Clock or Tenant Override Input

An input is supplied that can be used to accept a field wired start/stop signal from a remote source. An external time clock, a tenant override switch, or both may be connected. Whenever the external circuit is closed, the controller overrides the internal schedule (if activated) and places the unit into the occupied mode.

If the internal schedule or a BAS network schedule is used, field wiring is not required.

Timed Tenant Override

Off-hour operation flexibility is a must in today's office environments and the stand-alone MicroTech controls handle it with ease. When unit operation is desired during unoccupied hours the tenant override button on either of the optional zone sensor packages is pressed to initiate the override operation. The unit then starts and runs in the occupied mode for a keypad-adjustable length of time (up to five hours). If the button is pressed again while the unit is operating, the timer resets to the full time allowance without interrupting unit operation. Tenant override operation can also be initiated by a BAS.

Remote Set Point Adjustment Options

All constant air volume-zone temperature control (CAV-ZTC) unit controllers include an input that can be used to remotely adjust the zone cooling and heating set points. To use this feature, wire the optional zone sensor package with set point adjustment to the controller. The remote set point adjustment feature can be enabled or disabled from the keypad at any time. When enabled, the remote set point adjustment is available even if the return temperature is selected to be the control temperature.

The building automation system (BAS) can also remotely adjust the unit's setpoints.

Standard Control Options

MicroTech controls offer two basic control configurations; (1) variable air volume with discharge temperature control (VAV-DTC) or (2) constant air volume with zone temperature control (CAV-ZTC).

All control configurations use sophisticated state change control logic to provide stable, reliable and efficient control. When combined with MicroTech's many available control capabilities—both factory installed and keypad programmable—these basic configurations can be customized to meet the requirements of the most demanding applications.

Configuration 1: Variable Air Volume with Discharge Temperature Control (VAV-DTC)

MicroTech VAV-DTC controls provide discharge air temperature control along with duct static pressure control. The operator can enter the desired cooling set point and VAV parameters at the keypad.

Configuration 2: Constant Air Volume with Zone Temperature Control (CAV-ZTC)

MicroTech CAV-ZTC controls provide the sophisticated and flexible zone temperature control that is only possible with DDC systems. Zone temperature sensors are available with or without a remote set point adjustment. With the remote adjustment model, the space set point can be set at the keypad or at the zone sensor package. (Even if a zone sensor is connected, remote set point adjustment can be enabled or disabled as desired at the keypad.)

Control Temperature

The Control Temperature for VAV-DTC or CAV-ZTC determines whether the unit supplies heating, cooling, or neither. It also determines the amount of heating or cooling required to satisfy the load. Its source can be selected at the keypad from among the following selections:

- Zone temperature sensor
- Return temperature sensor

Supply Air Reset

By automatically varying the discharge air temperature to suit a building's cooling or heating needs, supply air temperature reset can increase the energy efficiency of VAV systems. MicroTech controllers offer a variety of different reset strategies that can be selected at the keypad. Because they are keypad-programmable, reset strategies can be changed or eliminated as desired. Separate strategies can be selected for both cooling and heating. If reset is not desired, a fixed discharge cooling or heating set point can be entered.

The following reset methods are available:

- Space temperature
- Return temperature
- Outdoor air temperature
- Supply airflow (VAV, cooling set point only)
- External 0–10 V (dc) or 0–20 mA signal
- Network communication

For all temperature reset methods, the minimum and maximum cooling and heating set points are keypad programmable along with the corresponding minimum and maximum space, return or outdoor air temperature parameters. For the supply airflow method, the discharge set point will be reset as the supply fan modulates between 30% (adjustable) and 100% (adjustable). For the external method, the discharge set point will be reset as the voltage or current signal varies over its entire range. For units in a BAS network, the discharge set points are reset via the communication signal.

Compressor Control

Compressor Staging

Compressor staging is controlled directly by the control temperature. When the control temperature is warmer than the cooling set point, cooling is staged up; when the control temperature is cooler than the cooling set point, cooling is staged down. However, a stage change can only occur when the control temperature is outside the dead band. Staging is constrained by an inter-stage delay timer (five minute default setting) and minimum and maximum discharge air temperature limits (all keypad programmable). These constraints protect the compressors from short cycling while eliminating temperature variations near the diffusers.

Project Ahead Algorithm

Because of the inherent thermal inertia in a building, zone temperature control applications can cause overshoot during warm-up or cool-down periods, MicroTech features a "Project Ahead" control algorithm. "Project Ahead" calculates the rate at which the control temperature is changing and reduces the unit's cooling or heating output as the zone temperature nears its set point, essentially eliminating overshoot.

Energy Recovery Control

The energy recovery wheel option has integrated control with the units DDC controller. Temperature sensors are mounted at the wheel to coordinate its operation with the rooftop unit. The outdoor air temperature, leaving wheel temperature, return air temperature, and exhaust air temperature are connected to the rooftop unit controller. These temperatures are also available as BACnet variables for the BAS integration option. The operational performance of the wheel and unit is maximized with this integrated control. The benefit of the integrated control is that it will monitor the leaving wheel temperature and prevent the wheel operation from overheating the outdoor air, which will force the building into the cooling mode of operation and consume more energy.

Frost control can be provided by a number of options. The standard offering for frost protection is to stop the wheel when a frost condition is encountered. The second option is to have the start-stop-jog control to prevent the wheel from reaching a frost condition. The third option for frost control is VFD proportional control. The speed of the wheel is varied to prevent the wheel from entering a frost condition. This option maximizes the amount of energy savings and also prevents the frost condition.

Supply Fan Control

Duct Static Pressure Control

On all VAV-DTC units, duct static pressure control is maintained by a control algorithm which provides precise control of the supply fan variable frequency drive. The keypad programmable set point can be set between 0.20" wc and 2.0" wc.

Economizer Control

Economizer Changeover Selection

On units equipped with an economizer, there are two methods of determining whether the outdoor air is suitable for free cooling.

- The standard offering uses an internal dry bulb changeover strategy: the unit controller compares the outdoor air dry-bulb temperature to a keypad-programmable set point
- The optional second method is a comparative enthalpy control. It uses a solid state device that compares the outdoor air ambient enthalpy to the return air enthalpy. When the outdoor air enthalpy is lower than the return air enthalpy, the unit will change to economizer operation

Minimum Ventilation Air Volume Control

Consistently maintaining the minimum outdoor air requirements of ASHRAE Standard 62 has been a long-standing control challenge for VAV systems. As supply air fan volumes were reduced, the volume of air introduced through a fixed-position, minimum outdoor air damper was also reduced, compromising indoor air quality. To meet this challenge, MicroTech controls feature user-selected control methods for maintaining outdoor air volume.

MicroTech controls have a keypad-selected control function that automatically adjusts outdoor air damper position in response to changes in supply air fan volume. Regardless of supply air volume, this strategy maintains a nearly constant outdoor air volume at all times.

The outdoor air damper position can also be controlled by the following:

- The MicroTech controller can accept an external 0–10 V (dc) or a 0–20 mA signal from a control device or from a CO₂ sensor
- The MicroTech controller can accept a BAS network signal for the minimum position
- A fixed minimum damper position can be keypad programmed. This selection may be acceptable when ventilation requirements are met through other sources. During cold ambient conditions where the mixed air temperature of the minimum outdoor air and the return air can become too low, MicroTech controls maintain the minimum discharge temperature set point by controlling the unit's heating system

Exhaust Fan Control

Building Static Pressure Control

Any constant or variable air volume Maverick unit with an optional variable volume exhaust fan can be provided with direct building static pressure control capability. The building static pressure is measured and processed by the unit DDC controller. The controller provides precise control of the exhaust fan's variable speed drive to maintain the space pressure set point. The range of the keypad-programmable set point is between $-0.25''$ and $+0.25''$ wc.

Field Output Signals

All MicroTech controls include two solid-state relay outputs that are available for field connection to any suitable device: a remote alarm output and a fan operation output. These outputs are used to signal field equipment of unit status.

Remote Alarm Output

The remote alarm output can be used to operate a 24 V relay to provide a remote alarm signal to a light, audible alarm, or other device when an alarm condition exists at the unit.

Fan Operation Output

The fan operation output is used to operate a 24 V relay to control field equipment that depends on fan operation, such as field-installed isolation dampers or VAV boxes. To allow actuators enough time to stroke, the fan operation output is energized three minutes before the fan starts. It then remains energized until thirty seconds after the unit airflow switch senses no airflow. The fan operation output is on whenever the unit airflow switch senses airflow.

Alarm Management and Control

MicroTech unit controllers are capable of sophisticated alarm management and controlled response functions. Each alarm is prioritized, indicated, and responded to with the appropriate action. The current alarm (up to four alarms, arranged by alarm priority), each with a time and date stamp, can be displayed at the user interface.

Alarm Priority

The various alarms that can occur are prioritized according to the severity of the problem. Three alarm categories are used: (1) Faults, (2) Problems, and (3) Warnings.

1. Faults are the highest priority alarms. If a fault condition occurs, the complete unit is shut down until the alarm condition is gone and the fault is manually cleared at the keypad. A fault example is a "Fan Fail" alarm.
2. Problems are the next lower priority to faults. If a problem occurs, the complete unit does not shut down, but its operation is modified to compensate for the alarm condition. A problem automatically clears when the alarm condition that caused it is gone. "Lo Pres-Ckt1" is an example of a problem where only the affected compressor is shut down.
3. Warnings are the lowest priority alarms. No control action is taken when a warning occurs; it is simply indicated to alert the operator that the alarm condition needs attention. To remind the operator to read warnings, they must be manually cleared. "Dirty Filter" indication is an example of a warning.

Table 1: MicroTech Alarm Summary

Alarm Name	Fault	Problem	Warning
Emergency Off	X		
Control T Fail	X		
Disch Sensor	X		
Duct Hi Limit	X		
Hi Return Tmp	X		
Hi Disch Tmp	X		
Lo Disch Tmp	X		
Fan Fail	X		
OAT Sensor		X	
Space Sensor		X	
Return Sensor		X	
Hi Pres-Ckt1		X	
Hi Pres-Ckt2		X	
Lo Pres-Ckt1		X	
Lo Pres-Ckt2		X	
Dirty Filter			X

Application Considerations

General Rooftop Applications

Units are intended for use in normal heating, ventilating, and air conditioning applications. Consult your local Daikin Applied sales representative for applications involving operation at high ambient temperatures, high altitudes, non-cataloged voltages, and for job specific unit selections that fall outside of the range of the catalog tables.

For proper operation, units should be rigged in accordance with instructions stated in [IM 842](#). Fire dampers, if required, must be installed in the ductwork according to local or state codes. No space is allowed for these dampers in the unit. Follow factory check, test and start procedures explicitly to achieve satisfactory start-up and operation (see [IM 842](#)).

Most rooftop applications take advantage of the significant energy savings provided with economizer operation. When an economizer system is used, mechanical refrigeration is typically not required below an ambient temperature of 50°F. Standard MPS refrigeration systems are designed to operate in ambient temperatures down to 20°F for 15–50 ton units or 45°F for 61–75 ton units. Maverick units with inverter compressors can provide mechanical cooling down to 35°F on 30–35 ton units and 0°F on 40–50 ton units.

Unit Location

The structural engineer must verify that the roof has adequate strength and ability to minimize deflection. Take extreme caution when using a wooden roof structure.

Unit condenser coils should be located to avoid contact with any heated exhaust air. If the unit is located in a corrosive environment, such as near the sea coast or industrial fumes, then, optional coated condenser coils are required.

Allow sufficient space around the unit for maintenance/service clearance. Refer to [Figure 17](#) for recommended clearances. Consult your Daikin Applied sales representative if available clearances do not meet minimum recommendations. Where code considerations, such as the NEC, require extended clearances, they take precedence.

Figure 17: MPS 015-075 Service Clearances (020 Show)

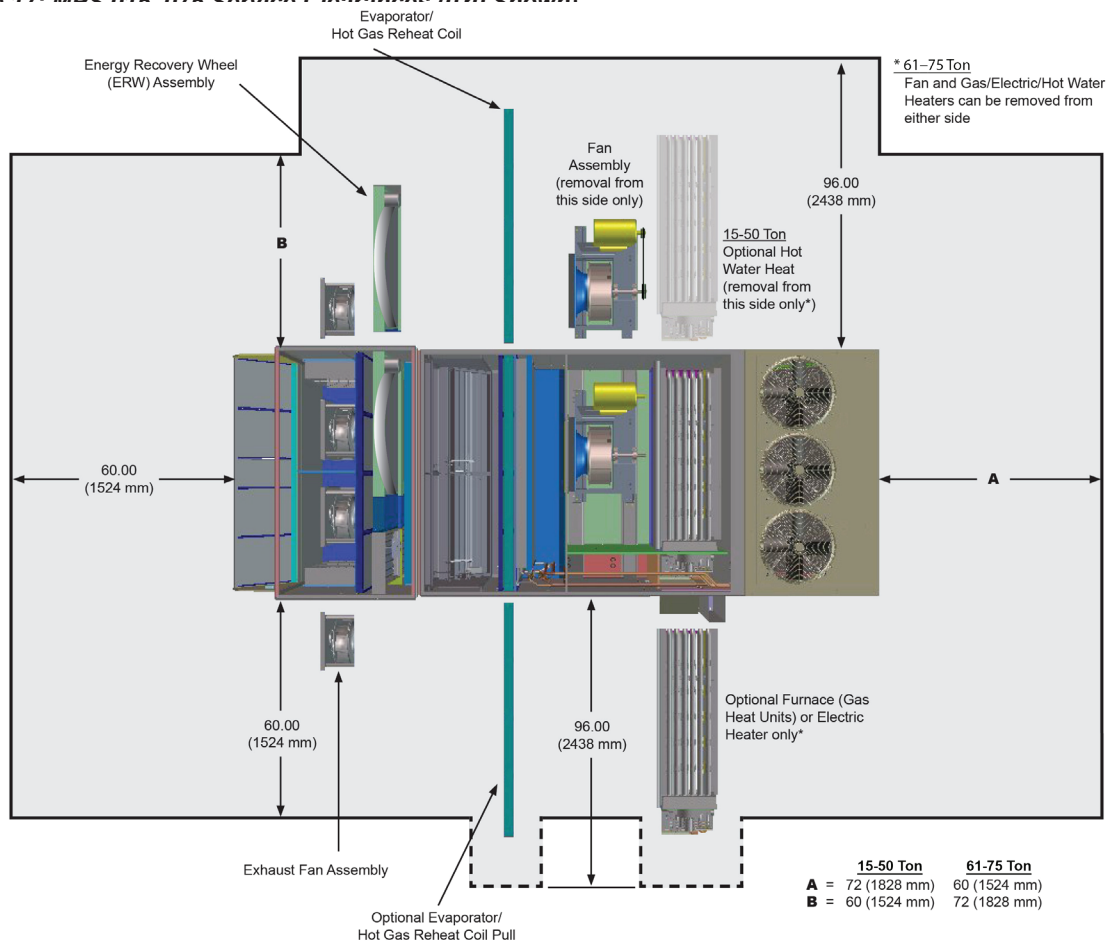

Service Clearance

Allow recommended service clearances as shown in Figure 13. Provide a roof walkway along the sides of the unit for service and access to controls and components. Contact your Daikin Applied sales representative for service requirements less than those recommended.

Curb Installation

The roof curb is field assembled and must be installed level (within 1/16" per foot side to side). A sub-base has to be constructed by the contractor in applications involving pitched roofs. Gaskets are furnished and must be installed between the unit and curb. For proper installation, follow NRCA guidelines. Typical curb installation is illustrated in [Figure 56 on page 61](#) and [Figure 65 on page 70](#). In applications requiring post and rail installation, an I-beam securely mounted on multiple posts should support the unit on each side. In addition the insulation on the underside of the unit should also be protected from the elements.

Applications in geographic areas subjected to seismic or hurricane conditions must meet code requirements for fastening the unit to the curb and the curb to the building structure.

Acoustical Considerations

Good acoustical design is critical for any installation and should start at the earliest stages in the design process. Common sound paths for rooftop equipment must be addressed are:

- Radiated sound through the bottom of the unit (air handling section and condensing section) and into the space
- Radiated sound to the property line
- Structure-borne vibration from the unit to the building
- Airborne sound through the supply air duct
- Airborne sound through the return air duct

Locating rooftop equipment away from sound sensitive areas is critical and the most cost effective means of avoiding sound problems. If possible, rooftop equipment should always be located over less sensitive areas such as corridors, toilet facilities or auxiliary spaces and away from office areas, conference rooms and classrooms.

Some basic guidelines for good acoustical performance are:

- Provide proper structural support under all areas of the unit
- Always locate the unit's center of gravity close to a main support to minimize roof deflection
- Use a concrete deck or pad when a unit has to be located over an occupied space where good acoustics are essential
- Only the supply and return air ducts should penetrate the acoustical material and decking within the curb perimeter, and the openings must be sealed once the duct is installed
- Don't overlook the return air path. Never leave a clear "line of sight" into a return or exhaust fan; always include some duct work (acoustically lined tee) at the return inlet
- Place an acoustical material in the area directly beneath the condensing section
- Select acoustical material that discourages microbial growth
- Minimize system static pressure losses to reduce fan sound generation
- Design duct systems to minimize turbulence
- Account for low frequency duct breakout in system design. Route the first 20 ft. of rectangular duct over non-sensitive areas and avoid large duct aspect ratios. Consider round or oval duct to reduce breakout

There are many sound sources in rooftop systems. Fans, compressors, condenser fans, duct take-offs, etc., all generate sound. For guidelines on reducing sound generation in the duct system, refer to the ASHRAE Applications Handbook.

Contact your local Daikin Applied sales representative for equipment supply, return and radiated sound power data specific to your application.

Ductwork Considerations

A well-designed duct system is required to allow the rooftop equipment to provide rated performance and to minimize system resistance and sound generation. Duct connections to and from units should allow straight, smooth airflow transitions. Avoid any abrupt change in duct size and sharp turns in the fan discharge. Avoid turns opposed to wheel rotation since they generate air turbulence and result in unwanted sound. If 90° turns are necessary, use turning vanes. Refer to the ASHRAE Applications Handbook for specific guidelines relevant to rooftop equipment.

Return Duct

The return path is the most often overlooked. A section of return duct is required to avoid a "line of sight" to the return air opening and to provide attenuation of return air sound. Install an insulated tee with a maximum duct velocity of 1000 to 1200 feet per minute. Extend the duct 15 feet to provide adequate attenuation.

Supply Duct

Insulate supply air ductwork for at least the first 20 feet from the unit. Consider the use of round or oval ductwork, as it significantly reduces low frequency breakout noise near the equipment. If rectangular duct is used, keep the aspect ratio of the duct as low as possible. The large flat surfaces associated with high aspect ratios increase low frequency breakout to the space and can generate noise, such as “oil canning.” The maximum recommended supply duct velocity is 1800 to 2000 feet per minute.

Duct High Limit

A Daikin Applied Packaged System with VAV control includes a duct high limit switch as a standard feature that is of particular importance when fast acting, normally closed boxes are used.

Vibration Isolation

Make duct attachments to the unit with a flexible connection.

Economizer and Exhaust Fan Application

Rooftop economizer applications usually require exhaust fans to properly control building pressure and maintain minimum ventilation.

The air balancer must adjust the outdoor air damper to provide minimum ventilation settings.

The EAF is normally off during non-economizer operation. During these minimum outdoor air conditions, the system essentially acts like a supply fan only system.

Smoke and Fire Protection

Due to the wide variation in building design and ambient operating conditions into which our units are applied, we do not represent or warrant that our products are fit and sufficient for smoke, fume, and fire control purposes. The owner and a fully qualified building designer are responsible for meeting all local and NFPA building code requirements with respect to smoke, fume, and fire control.

The unit’s control panel has a terminal block that a supply air and return air smoke detector can be wired to. An optional return air smoke detector is offered. Any other smoke detector, its installation, and the wiring to the unit controller are all field supplied.

Variable Air Volume Application

MPS units are available with variable speed drives to provide variable air volume (VAV) control as shown in Figure 14.

Daikin Applied MPS variable air volume systems (VAV) employ the concept of varying the air quantity to a space at a constant temperature, thereby balancing the heat gains or losses and maintaining the desired room temperature. This ability to reduce supply air quantities not only provides substantial fan energy savings at partial load conditions, but it also minimizes equipment sizing.

Variable volume systems offer the following advantages:

- Lower system first cost by using system diversity to reduce equipment and duct sizes
- Lower operating costs by reducing fan energy demands, especially at part load conditions
- Acoustical sound performance is reduced at the lower airflows

Figure 18: Variable Air Volume (VAV) Control

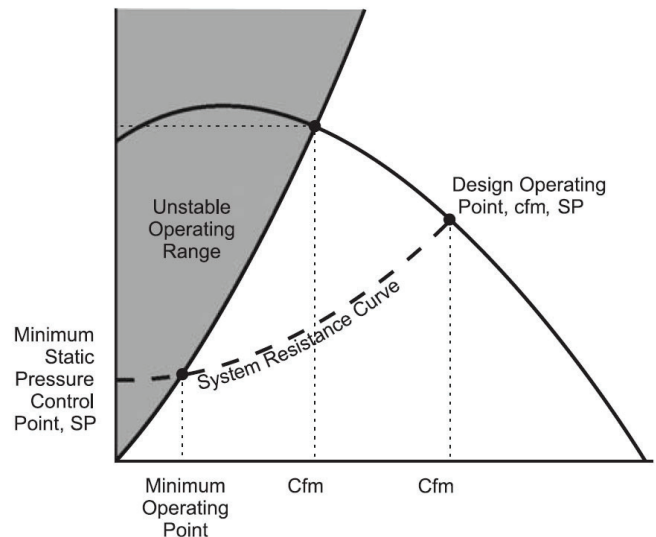

In placing a duct static pressure sensor, locate a pressure tap near the end of the main duct trunk. Adjust the static pressure set point so that at minimum airflow all of the terminals receive the minimum static pressure required plus any downstream resistance. Locate the static pressure sensor tap in the ductwork in an area free from turbulence effects and at least ten duct diameters downstream and several duct diameters upstream from any major interference, including branch takeoffs.

Fan Isolation

All Daikin Applied MPS systems feature internally isolated fans. All supply fans are statically and dynamically balanced in the factory. 15–50 ton unit springs have 1" deflection and 61–75 ton unit springs have 2" deflection. Flexible isolation is provided as standard between the fan and bulkhead to prevent hard contact and vibration transmission.

When using an isolation curb, consult with the curb manufacturer to confirm no resonant vibration situation can occur between the fan and roof curb.

Normally, 15–50 ton unit springs are left in the tied down position. Optional rubber and shear isolators should be ordered for 61–75 ton units.

Fan Operating Range

The acceptable system operating range of the Daikin Applied rooftop is determined by all of the following characteristics. Each of these limiting factors must be considered for proper performance and component design life:

- Unstable fan operation
- Maximum fan rpm
- Maximum cabinet static pressure
- Maximum face velocity (cooling coil is most important)
- Minimum furnace velocity
- Turndown capability on VAV applications
- Compressor operating pressures

Indoor Fan and Motor Heat

The indoor fan and motor electrical consumption is a sensible cooling load approximately equal to 2.8 MBh per bhp (depending slightly on motor efficiency). The fan and motor temperature rise is equal to $Btuh / (1.08 \times cfm)$ and is typically about 3°F.

Ambient Operating Ranges for Compressors

Maverick MPS II units have two independent refrigerant circuits with one to three condenser fans on each circuit depending on unit size. Head pressure is maintained by cycling condenser fans of each refrigeration circuit automatically in response to ambient air temperature.

- Maverick II 15-50 ton units allows mechanical cooling operation down to 0°F ambient temperatures for fixed speed scroll unit
- Maverick II 26-50 ton units with variable speed scroll compressor allows mechanical cooling operation down to 35°F on 30–35 ton units and 0°F on 40–50 ton units
- Maverick II 61-75 ton units allows mechanical cooling operation down to 45°F ambient temperatures and 0°F ambient temperatures for unit with variable speed condenser fan, low ambient option

Altitude Adjustments

Fan Curve Performance

Fan curve performance is based on 70°F air temperature and sea level elevation. Selections at any other conditions require adjustment for air densities listed in Table 2. Higher elevations generally require more rpm to provide a given static pressure but less bhp due to the decrease in air density.

Example:

Assume 12,000 cfm is required at 2.0" TSP. The elevation is 5000 ft. and 70°F average air temperature is selected. A 24" SWSI airfoil fan is selected.

1. The density adjustment factor for 5000 ft. and 70°F is 0.83.
2. TSP must be adjusted as follows: $2.0" / 0.83 = 2.4"$.
3. Locate 12,000 cfm and 2.4 on the fan curve. $Rpm = 1700$ and $bhp = 9$.
4. Consumed fan power at design = $9 bhp \times 0.83 = 7.5 bhp$.

Table 2: Temperature and Altitude Conversion Factors

Air Temp (°F)	Altitude (feet)								
	0	1000	2000	3000	4000	5000	6000	7000	8000
-20	1.20	1.16	1.12	1.08	1.04	1.00	0.97	0.93	0.89
0	1.15	1.10	1.08	1.02	0.99	0.95	0.92	0.88	0.85
20	1.11	1.06	1.02	0.98	0.95	0.92	0.88	0.85	0.82
40	1.06	1.02	0.98	0.94	0.91	0.88	0.84	0.81	0.78
60	1.02	0.98	0.94	0.91	0.88	0.85	0.81	0.79	0.76
70	1.00	0.96	0.93	0.89	0.86	0.83	0.80	0.77	0.74
80	0.98	0.94	0.91	0.88	0.84	0.81	0.78	0.75	0.72
100	0.94	0.91	0.88	0.84	0.81	0.78	0.75	0.72	0.70
120	0.92	0.88	0.85	0.81	0.78	0.76	0.72	0.70	0.67
140	0.89	0.85	0.82	0.79	0.76	0.73	0.70	0.78	0.65

Condenser Performance

Altitudes greater than sea level require a derate in condenser and cooling performance that can be estimated as follows:

For altitudes up to 6000 feet:

- Cooling capacity decrease factor (all sizes) = 0.5% per 1000 feet
- Compressor kW increase factor = 0.6% per 1000 feet

For altitudes above 6000 feet, consult the factory. The actual derate varies with each individual unit and design conditions. Your local Daikin Applied representative can provide exact performance data.

Furnace Performance

Gas heat performance data is based on standard 70°F air temperature and zero feet altitude (sea level).

For altitudes between 2000 to 6000 feet, the gas burner must be derated 4% for every 1000 feet of altitude.

Example:

A 400 MBh furnace at an altitude of 3000 feet is derated ($0.04 \times 3 = 0.12$). At 400 MBh input (400×0.12 MBh), the actual input is ($400 - 48 = 352$ MBh) at 3000 feet.

For altitudes above 6000 feet, consult the factory.

System Operating Limits

Daikin Applied MPS systems are designed to operate over an extensive operating range. However, for proper system operation some limits do apply.

To help prevent moisture blow-off, design guidelines have been established for cooling coil selection. Based on laboratory testing, average coil face velocities should not exceed 600 ft./min. For applications outside of these limits, consult your Daikin Applied sales representative.

In addition to maximum face velocity limitations, minimum velocity guidelines must also be followed. In order to maintain proper refrigeration performance, the minimum coil face velocity is 175 ft./min. When selecting a variable air volume unit, it is necessary to design the system such that the 175 ft./min. limit is maintained at light load conditions.

Condensate Drainage

Provide all drain pans with a properly sized p-trap to allow free drainage of coil condensate. For trap sizing, follow instruction given in [IM 842](#). Run all traps and drain lines full size from the threaded unit connection to the roof drain.

Zone Sensor Placement

Placement of the zone temperature sensor is critical for proper and economical operation of the heating and cooling system. It is generally recommended that the space sensor be located on an inside wall (3 to 5 feet from an outside wall) in a space having a floor area of at least 400 square feet. Do not locate the sensor below the outlet of a supply diffuser, in the direct rays of the sun, on a wall adjacent to an unheated or abnormally warm room (boiler or incinerator room), or near any heat producing equipment. Where zone sensor placement is a problem, all zone control systems, as standard, have the capability to use a return air sensor for heating and cooling.

Unit Wiring

All units require three phase, 60 Hz, 208, 230, 460, or 575 volt power supply. All units include branch circuits and short circuit protection and are available with a power block or non-fused disconnect switch. Each unit is provided with a 115V convenience outlet. Per the NEC, this circuit must be fed independent of the main unit power supply.

All wiring must be installed in accordance with the National Electric Code (NEC) and local codes.

Winter Shipment

Flat bed shipment in winter can expose units to harsh road chemicals. Since equipment size and configuration precludes covering during transit, wash units free of these chemicals as soon as possible to help prevent corrosion.

Coil Freeze Protection

When applying roof-mounted equipment in areas that experience subfreezing conditions, coil freeze protection measures must be provided. Subfreezing temperatures can adversely affect water and steam coils during controlled or uncontrolled unit shutdowns and even during unit operation. Daikin Applied economizer dampers are arranged to direct the outside and return air streams toward each other, however, there may not always be a uniform unit temperature profile under all load and ambient temperatures. Some temperature stratification will occur, particularly at low ambient temperatures and the associated reduced airflow inherent with VAV systems.

Glycol is strongly recommended as a positive means of freeze protection for water coils. No control sequence can prevent coil freezing in the event of a power failure or equipment malfunction. During those periods, glycol is the only positive means of freeze protection. When selecting water coils, specify glycol to account for performance differences.

Freeze protection control strategies must be designed to keep unit cabinet temperatures from exceeding 150°F during a unit shutdown. Temperatures in excess of 150°F may exceed the design limits of motors, electrical components, gaskets, etc. potentially leading to premature failure of components.

Unit Selection

Achieving Optimal Performance

Achieving the optimal performance of a rooftop system requires both accurate system design and proper equipment selection. Factors that control the unit selection include applicable codes, ventilation and air filtration requirements, heating and cooling loads, acceptable temperature differentials, and installation limitations.

The Daikin Applied SelectTools™ software selection program allows your local Daikin Applied sales representative to provide you with fast, accurate and complete selection of Daikin Applied MPS units. You also can select your unit through reference to physical, performance, dimensional, and unit weight data included in this catalog.

To properly select unit equipment:

1. Select unit size and cooling coil.
2. Select heating coils and equipment.
3. Select fans and motors.

Below are examples that illustrate the equations and catalog references used in the unit selection process.

Table 3: Selection Example

A constant volume system with DX cooling and natural gas heat is required to meet the following criteria:	
Supply air volume	= 14,000 cfm
Return air volume	= 11,200 cfm
Minimum outside air volume	= 2800 cfm
Maximum face velocity	= 550 fpm
Supply ductwork external SP	= 1.50-in. w.g.
Return ductwork external SP	= 0.50-in. w.g.
Altitude	= Sea level
Economizer	= Required
30% throw-away filters	= Required
Voltage	= 460 V/60 Hz/3 Ph
Natural gas heat	= Required
Double-wall construction	= Required
Summer Design:	
Mixed air temperature	= 80°F/67°F
Total sensible load	= 345,000 Btu/hr
Total load	= 450,000 Btu/hr
Space supply air temperature	= 60°F
Ambient conditions	= 95°F/76°F
Est. supply fan sensible heat rise (included in above sensible load)	= 3°F
Winter Design:	
Return air temperature	= 70°F
Ambient temperature	= 10°F
Space heating load	= 315,000 Btu/hr

Selecting Unit Size to Satisfy Summer Design

Unit size is based on coil face area and cooling capacity requirements. Supply air capacity and maximum face velocity constraints should serve as a guide for selecting coil dimensions and cabinet size.

Based on the given data in [Table 3](#), the appropriate coil face area may be determined as follows:

$$\begin{aligned} \text{Minimum face} &= \text{supply air volume}/\text{max. face velocity area} \\ &= 14,000 \text{ cfm}/550 \text{ fpm} \\ &= 25.5 \text{ square feet} \end{aligned}$$

NOTE: Unit data is based on standard air conditions of 70°F at sea level. Refer to [Application Considerations on page 22](#) for temperature/altitude conversion factors for nonstandard conditions.

Referring to [Physical Data on page 29](#), the 29.4 square foot coil of the MPS 040A unit satisfies the required face velocity.

Using the [Performance Data on page 33](#), the unit selection is an MPS 040A. Unit performance equals 457,000 Btu/hr. total, 350,000 Btu/hr. Sensible.

$$\begin{aligned} \text{Supply air dry bulb} &= 80^\circ\text{F} - 350 \text{ MBh}/(1.085 \times 14,000 \text{ cfm}) \\ &= 57.0^\circ\text{F} \end{aligned}$$

Once the initial unit selection is made, determine the actual supply fan heat rise and check and verify the selection for net capacity and supply air temperature.

Selecting the Unit Heating System

Heating equipment and coils can be specified directly from figures and tables incorporated in [Hot Water Heating Capacity on page 33](#).

Calculating Total Heating Load

$$\begin{aligned} \text{Total heating load} &= \text{Space heating load} + \text{Outdoor air load} \\ &\quad - \text{Supply fan heat} \end{aligned}$$

From the data given in [Table 3](#), the outdoor air load is (1.085×2800)

$$(70 - 10) / 1000 = 182 \text{ MBh and supply fan heat is } 46 \text{ MBh.}$$

$$\text{Total heat load} = 315 \text{ MBh} + 182 \text{ MBh} - 46 \text{ MBh} = 451 \text{ MBh}$$

Selecting Fans and Motors

Fan and motor selections are based on total static pressure drop and design airflow. Total static pressure includes internal air pressure drops of unit components and external air pressure drops in supply and return ducts. Refer to [Pressure Drops on page 35](#) for internal pressure drops of unit components.

When selecting unit fans and motors, use the fan curves provided in [Figure 36](#) and [Figure 37 on page 46](#).

Select the motor size most closely above the application brake horsepower. (Example: For an application brake horsepower of 7 bhp, select a 7.5 hp motor). An oversized motor (large horsepower to load ratio) can greatly increase electric consumption due to the reduction in motor performance.

Exhaust Fan and Motor

Exhaust fans must be sized for maximum exhaust cfm and return duct ESP at those conditions. See [Hot Water Pressure Drop Curves on page 42](#) for more information.

Supply Fan and Motor

Since the system in [Table 3](#) includes a return fan, the return duct static pressure drop is not added to the supply fan pressure drop. Therefore, the total static pressure for the supply fan in [Table 3](#) is as follows:

Internal pressure drops:

- 0–100% economizer, with RAF = 0.17-in. w.g.
- 30% filters = 0.13-in. w.g.
- Evaporative coil = 0.61-in. w.g.
- Total internal pressure drop = 1.16-in. w.g.*

External pressure drops:

- Supply duct = 1.50-in. w.g.
- Return duct = 0.50-in. w.g.
- Total external pressure drop = 2.00-in. w.g.*

$$\begin{aligned} \text{Total static pressure} &= \text{internal drops} + \text{external drops} \\ &= 1.16 + 2.00 \\ &= 3.16\text{-in. w.g.} \end{aligned}$$

Entering the MPS 040A fan curve at 14,000 cfm and 3.16-in. w.g., the required fan motor size is 15 hp operating at 1325 rpm. Fan brake horsepower is 12.9 horsepower.

The total fan and motor heat for the supply fan is as follows:
(12.9) bhp × 2.8 MBh/bhp = 36 MBh

Additional Weights When Selecting Motors

[Table 4](#) and [Table 5](#) lists additional weights when selecting a motor and exhaust fan. See [Physical Data on page 29](#) for base unit weights, capacities and physical data.

Table 4: Additional Weights When Selecting Motors/ Exhaust Fans (015–020 units)

HP	Additional Motor Weight (lbs)	UnitTons	Additional Exhaust Fan Weight (lbs)
1	0	15	150
1.5	9	17	150
2	9	20	150
3	32		
5	43		

Table 5: Additional Weights When Selecting Motors/ Exhaust Fans (026–050 units)

HP	Additional Motor Weight (lbs)	Unit Tons	Additional Exhaust Fan Weight (lbs)
7.5	0	26	150
10	25	30	150
15	125	35	150
20	175	40	200
25	225	50	200
30	275		

NOTE: See [Table 34 on page 82](#) for additional weights on 61–75 ton units.

Supply Power Wiring for Units Without Electric Heat

Sizing supply power wire for a unit is based on the circuit with the largest amperage draw. All electrical equipment is wired to a central panel for single or optional multipower connections. Refer to [Electrical Data on page 83](#) for FLA and RLA ratings of equipment. Determination of Minimum Circuit Ampacity (MCA) for a 460 V unit with standard condenser fans and R410A is as follows:

Fans and Cooling

$$\text{MCA} = 1.25 \times (\text{RLA or FLA of largest motor}) + \text{FLA of all other loads}$$

Example:

- | | |
|--------------------------------|-----------------------|
| | <u>FLA/RLA</u> |
| Compressor 1, 2, 3 | = 16.5, 16.5, 14 amps |
| Condenser fan motors, (3) 1 hp | = 2 amps ea. |
| Supply fan motor, 15 hp | = 17.7 amps |
| Controls | = 1 amps |

Therefore,

$$\text{MCA} = (1.25 \times 17.7) + 16.5 + 16.5 + 14.0 + (3 \times 2) + 1 = 76 \text{ amps}$$

NOTE: In the above example, the selected power supply wire is based on 90 amperes.

Physical Data

Table 6: MPS 015–026 Unit Capacity and Physical Data

Model	MPS			
	015	017	020	026
Cooling Performance				
Gross cooling capacity (tons)	16.0	18.5	22.4	25.3
Nominal airflow (cfm)	6000	7000	8000	10,000
Maximum EER ³	N/A	N/A	10.0	11.1
Maximum IEER (VAV) ³	N/A	N/A	12.5	12.8
Gas Heating Performance				
Low heat MBH (input/output) ²	240/192	240/192	240/192	300/240
Number of stages (low heat)	2	2	2	2
Turndown (low heat) ²	4:1	4:1	4:1	4:1
Gas connection pipe size/qty (low heat) ¹	3/4"/1	3/4"/1	3/4"/1	3/4"/1
High heat MBH (input/output) ²	480/384	480/384	480/384	600/480
Number of stages (high heat)	4	4	4	4
Turndown (high heat)	8:1	8:1	8:1	8:1
Steady state efficiency	80%	80%	80%	80%
Hot Water Heating Performance				
Face area (sq ft)	12.2	12.2	12.25	19.25
Rows/FPI (low heat)	1/11	1/11	1/14	1/14
Coil model (low heat)	5WB	5WB	5WB	5WB
Connection sizes/type (low heat)	ODM Sweat	ODM Sweat	ODM Sweat	ODM Sweat
Rows/FPI (high heat)	2/12	2/12	2/9	2/10
Coil model (high heat)	5WB	5WB	5WS	5WS
Connection sizes/type (high heat)	ODM Sweat	ODM Sweat	ODM Sweat	ODM Sweat
Electric Heating Performance				
Number of stages	4	4	4	4
kW (low/medium/high heat)	18/36/54	18/36/54	36/54/72	54/72/90
Compressors⁴				
Quantity/Type	2/Fixed Speed Scroll		3/Fixed Speed Scroll	
Number of stages/Capacity control	2/Staged		4/Staged	
Number of refrigeration circuits	2			
Evaporator Coils				
Rows/FPI	4/14	4/14	6/13	4/12
Face area (sq ft)	18.2	18.2	18.2	25.4
Capacity control	TXV	TXV	TXV	TXV
Hot Gas Reheat				
Coil type	Microchannel	Microchannel	Microchannel	Microchannel
Control type	Modulating	Modulating	Modulating	Modulating
Face area (sq ft)	14.1	14.1	14.1	19.9
Minimum temperature rise	20°	20°	20°	20°
Condenser Coils				
Fin type	Enhanced	Enhanced	Enhanced	Enhanced
FPI	18	18	18	18
Face area (sq ft)	36.2	36.2	36.2	41.2
Outdoor Fans				
Type	Propeller	Propeller	Propeller	Propeller
Number – diameter	2–26"	2–26"	2–26"	3–26"
Drive type/number of speeds	Direct/1	Direct/1	Direct/1	Direct/1
Indoor Fans				
Type	AF - SWSI	AF - SWSI	AF - SWSI	AF - SWSI
Number – diameter	1–18"	1–20"	1–22"	1–24"
Drive type	Fixed sheave	Fixed sheave	Fixed sheave	Fixed sheave
Isolation	1" spring	1" spring	1" spring	1" spring
Number of motors	1	1	1	1
Motor hp range	1.5–10	1.5–10	2–15	5–20
Motor nominal rpm	1800	1800	1800	1800
Motor efficiency	Premium	Premium	Premium	Premium
Filters (Mixed Air)				
Type	2", MERV 8			
Area (sq ft)	24	24	24	32
Qty. – size	6–24" × 24"	6–24" × 24"	6–24" × 24"	8–24" × 24"
Energy Recovery Wheel Filters for both Outdoor Air and Return Air				
Type	2", MERV 8			
Area (sq ft)	12	12	12	16
Qty. – size	3–24" × 24"	3–24" × 24"	3–24" × 24"	4–24" × 24"

- Note:
- 1) Piping connections are given with a male outside diameter dimension, brazed connection.
 - 2) Heating output is for standard conditions at sea level.
 - 3) AHRI performance
 - 4) Compressor information for units with Fixed Speed Compressors only.

Table 7: MPS 030–050 Unit Capacity and Physical Data

Model	MPS			
	030	035	040	050
Cooling Performance				
Gross cooling capacity (tons)	30.0	34.0	40.0	50.0
Nominal airflow (cfm)	12,000	14,000	16,000	20,000
Maximum EER ³	10.3	10.1	10.3	10.4
Maximum IEER (VAV) ³	13.1	12.8	13.6	14.1
Gas Heating Performance				
Low heat MBH (input/output) ²	300/240	300/240	400/320	400/320
Number of stages (low heat)	2	2	2	2
Turndown (low heat)	4:1	4:1	4:1	4:1
Gas connection pipe size/qty (low heat) ¹	3/4"/1	3/4"/1	3/4"/1	3/4"/1
High heat MBH (input/output) ²	600/480	600/480	800/640	800/640
Number of stages (high heat)	4	4	4	4
Turndown (high heat)	8:1	8:1	8:1	8:1
Steady state efficiency	80%	80%	80%	80%
Hot Water Heating Performance				
Face area (sq ft)	19.25	19.25	19.25	19.25
Rows/FPI (low heat)	1/12	1/12	1/11	1/11
Coil model (low heat)	5WB	5WB	5WH	5WH
Connection sizes/type (low heat)	ODM Sweat	ODM Sweat	ODM Sweat	ODM Sweat
Rows/FPI (high heat)	2/10	2/10	2/13	2/13
Coil model (high heat)	5WS	5WS	5WS	5WS
Connection sizes/type (high heat)	ODM Sweat	ODM Sweat	ODM Sweat	ODM Sweat
Electric Heating Performance				
Number of stages	4	4	4	4
kW (low/medium/high heat)	54/72/90	54/72/90	72/90/108	72/90/108
Compressors⁴				
Quantity/Type	3/Fixed Speed Scroll		4/Fixed Speed Scroll	
Number of stages/Capacity control	5/Staged			
Number of refrigeration circuits	2			
Compressors^{5, 6}				
Quantity/Type	(1) Variable Speed and (2) Fixed Speed Compressors ⁷		(1) Variable Speed and (3) Fixed Speed Compressors	
Capacity control/Capacity steps %	Modulating/20–100			
Number of refrigeration circuits	2			
Evaporator Coils				
Rows/FPI	4/12	4/12	4/12	4/12
Face area (sq ft)	25.4	25.4	35.7	35.7
Capacity control	TXV	TXV	TXV	TXV
Hot Gas Reheat Coils				
Coil type	Microchannel	Microchannel	Microchannel	Microchannel
Control type	Modulating	Modulating	Modulating	Modulating
Face area (sq ft)	19.9	19.9	26.8	26.8
Minimum temperature rise	20°	20°	20°	20°
Condenser Coils				
Fin type	Enhanced	Enhanced	Enhanced	Enhanced
FPI	18	18	18	18
Face area (sq ft)	41.2	41.2	74.7	74.7
Outdoor Fans				
Type	Propeller	Propeller	Propeller	Propeller
Number – diameter	3–26"	3–26"	4–26"	4–26"
Drive type/number of speeds	Direct/1	Direct/1	Direct/1	Direct/1
Indoor Fans				
Type	AF–SWSI	AF–SWSI	AF–SWSI	AF–SWSI
Number – diameter	1–24"	1–24"	1–30"	1–30"
Drive type	Fixed sheave	Fixed sheave	Fixed sheave	Fixed sheave
Isolation	1" spring	1" spring	1" spring	1" spring
Number of motors	1	1	1	1
Motor hp range	5–20	5–20	7-1/2–30	7-1/2–30
Motor nominal rpm	1800	1800	1800	1800
Motor efficiency	Premium	Premium	Premium	Premium
Filters (Mixed Air)				
Type	2", MERV 8			
Area (sq ft)	32	32	44	44
Qty. – size	8–24" × 24"	8–24" × 24"	8–24" × 24" / 4–18" × 24"	8–24" × 24" / 4–18" × 24"
Energy Recovery Wheel Filters for both Outdoor Air and Return Air				
Type	2", MERV 8			
Area (sq ft)	16	16	24	24
Qty. – size	4–24" × 24"	4–24" × 24"	8–24" × 24"	8–24" × 24"

- Note:
- 1) Piping connections are given with a male outside diameter dimension, brazed connection.
 - 2) Heating output is for standard conditions at sea level.
 - 3) AHRI performance.
 - 4) Compressor information for units with Fixed Speed Compressors only.
 - 5) Unit model numbers and compressor information with Variable Speed Compressors.
 - 6) Mechanical cooling down to 35°F (30–35 tons) or 0°F (40–50 tons) ambient temperature with Variable Speed Compressors.
 - 7) Variable speed compressor option not available on MPS 035, 208 volt units

Table 8: MPS 061–075 Unit Capacity and Physical Data

Model	MPS		
	061	070	075
Cooling Performance			
Nominal gross cooling capacity (tons)	61.0	70.0	75.0
Nominal airflow (cfm)	24,000	26,000	28,000
Maximum EER ³	10.0	9.7	9.4
Maximum IEER ³	13.2	13.6	12.9
Gas Heating Performance			
Low heat MBH (input/output) ²	500/400	500/400	500/400
Gas connection pipe size/qty (low heat) ¹	1"/1	1"/1	1"/1
Medium heat MBH (input/output) ²	600/480	600/480	800/640
Gas connection pipe size/qty (medium heat) ¹	1-1/4"/1	1-1/4"/1	1-1/4"/1
High heat MBH (input/output) ²	980/790	980/790	980/790
Number of stages - all furnaces	Mod	Mod	Mod
Turndown - all furnaces	3:1	3:1	3:1
Steady state efficiency - all furnaces	80%	80%	80%
Hot Water Heating Performance			
Face area (sq ft)	29.7	29.7	29.7
Type—rows (standard / high capacity)	5WH-1 / 5WS-2	5WH-1 / 5WS-2	5WH-1 / 5WS-2
FPI	9	9	9
Electric Heating Performance			
Number of stages	4	4	4
kW (low/medium/high heat)	100/120/160	100/120/160	100/120/160
Compressors			
Type/number	Scroll/4	Scroll/6	Scroll/6
Number of stages	4	6	6
Evaporator Coils			
Rows/FPI	5/10	5/10	5/10
Face area (sq ft)	39.5 or 47.1	47.1	47.1
Capacity control	TXV	TXV	TXV
Condenser Coils			
Fin type	Enhanced	Enhanced	Enhanced
FPI	18	18	18
Face area (sq ft)	32.1 × 2	37.3 × 2	37.3 × 2
Outdoor Fans			
Type	Propeller	Propeller	Propeller
Number - diameter	6–26"	6–26"	8–26"
Drive type/number of speeds	Direct/1	Direct/1	Direct/1
Indoor Fans			
SWSI AF		1–44"	
DWDI AF		1–30" or 1–33"	
Drive type		Fixed sheave	
Isolation		2" spring	
Number of motors		1	
Motor hp range		5–40	
Motor nominal rpm		1800	
Motor efficiency		Premium	
Filters (Mixed Air)			
Qty. - type / sq. ft.	Merv 8 angular	(7) 16 × 20 and (21) 16 × 25 / 73 sq. ft.	
	6" Merv 11 or 12" Merv 14	(4) 12 × 24 and (8) 24 × 24 / 40 sq. ft. standard air flow (8) 12 × 24 and (8) 24 × 24 / 48 sq. ft. high air flow	
Energy Recovery Wheel Filters for both Outdoor Air and Return Air			
Type		2", MERV 8	
Area (sq ft)		30 sq. ft.	
Qty. - size		7—16" × 20" plus 21—16" × 25"	

Note: 1) Piping connections are given with a male outside diameter dimension, brazed connection.
 2) Heating output is for standard conditions at sea level.
 3) AHRI performance

Table 9: MPS Refrigerant Charge Table*

Size (ton)	Evaporator	Circuit 1		Circuit 1 with HGRH		Circuit 2	
		lbs.	kg.	lbs.	kg.	lbs.	kg.
15F	4-row	9.0	4.1	17.3	7.8	9.0	4.1
	6-row	10.4	4.7	18.7	8.4	10.4	4.7
17F	4-row	9.0	4.1	17.3	7.8	10.0	4.5
	6-row	10.4	4.7	18.7	8.4	11.5	5.2
20G	6-row	12.7	5.8	21.0	9.6	14.4	6.6
26G	4-row	21.8	9.9	32.8	14.9	10.2	4.6
	6-row	24.8	11.2	35.8	16.2	11.9	5.4
30F	4-row	22.8	10.3	34.5	15.6	12.1	5.5
	6-row	25.7	11.7	37.4	17.0	13.6	6.2
35F	4-row	22.8	10.3	34.5	15.6	12.4	5.6
	6-row	25.7	11.7	37.4	17.0	14.0	6.4
40F	4-row	25.5	11.6	42.5	19.3	26.0	11.8
	6-row	29.0	13.2	46.0	20.9	29.5	13.4
50F	4-row	28.6	13.0	45.6	20.7	29.1	13.2
	6-row	32.1	14.5	49.1	22.2	32.6	14.8

* For Fixed Speed Scroll Compressor Units

Performance Data

Electric Heating Capacity

Table 10: MPS 015–075 Electric Heating Capacities

Unit	Nom. cfm	Stages	Low Heat				Medium Heat			High Heat				
			kW	MBh	Delta T*	Min. cfm	kW	MBh	Delta T*	Min. cfm	kW	MBh	Delta T*	Min. cfm
015	6000	4	18	61	9.3	950	36	123	18.6	1900	72	246	37.2	3800
017	6800	4	18	61	8.2	950	36	123	16.4	1900	72	246	32.8	3800
020	8000	4	36	123	14.1	1900	54	184	21.1	2900	72	246	28.2	3800
026	10,000	4	54	184	16.9	2900	72	246	25.5	3800	90	307	31.4	4800
030	12,000	4	54	184	14.2	2900	72	246	19.0	3800	90	307	23.7	4800
035	14,000	4	54	184	12.2	2900	72	246	16.3	3800	90	307	20.3	4800
040	16,000	4	72	246	14.2	3800	90	307	17.8	4800	108	369	21.3	5700
050	20,000	4	72	246	11.4	3800	90	307	14.2	4800	108	369	17.1	5700
061	24,000	4	100	342	13.1	14,000	160	546	21.0	14,000	200	684	26.3	14,000
070	26,000	4	100	342	12.1	14,000	160	546	19.6	14,000	200	684	24.2	14,000
075	28,000	4	100	342	11.3	14,000	160	546	18.0	14,000	200	684	22.5	14,000

Note: * Temperature rise is calculated at nominal cfm

Hot Water Heating Capacity

Table 11: MPS 015–050 Hot Water Heating Capacities

Unit	Nom. cfm	Low Heat					High Heat				
		MBh	Delta T*	GPM	Min. cfm	Inlet dia.	MBh	Delta T*	GPM	Min. cfm	Inlet dia.
015	6000	145	22.4	25.9	1850	1.5	270	41.7	25.9	1850	1.5
017	6800	158	21.5	30.2	1850	1.5	302	41.1	32.0	1850	1.5
020	8000	233	26.6	26.6	1850	1.5	415	40.7	40.0	1850	1.5
026	10,000	312	28.6	32.8	2900	1.5	640	58.5	63.0	2900	2.5
030	12,000	297	22.8	29.0	2900	1.5	553	42.5	57.2	2900	2.5
035	14,000	315	20.7	30.5	2900	1.5	614	40.4	60.8	2900	2.5
040	16,000	389	22.4	34.0	2900	1.5	758	43.7	69.5	2900	2.5
050	20,000	446	20.6	43.4	2900	1.5	878	40.5	87.0	2900	2.5

Note: * Temperature rise is calculated at nominal cfm. Water temperature drop = 20°

Gas Heating Capacity

Table 12: MPS 015–075 Gas Heating Capacities

Data	Unit Size								
	015–020		026–035		040–050		061, 070, 075		
	Low Heat	High Heat	Low Heat	High Heat	Low Heat	High Heat	Low Heat	Medium Heat	High Heat
Heating Input (MBh)	240	480	300	600	400	800	500	800	988
Heating Output (MBh)	192	384	243	486	320	640	400	640	790
Steady State Efficiency	80%	80%	81%	81%	80%	80%	80%	80%	80%
Number of Stages	2	4	2	4	2	4	Mod	Mod	Mod
Turndown ¹	4:1	8:1	4:1	8:1	4:1	8:1	3:1	3:1	3:1
Minimum Airflow*	2960	5920	3700	7400	4900	9800	6000	9600	12,000
Maximum Temperature Rise	60°F	60/100°F ⁴	60°F	60/85°F ⁴	60°F	60/85°F ⁴	61°F	61°F	61°F
Gas Main Pressure									
Natural Gas (in. wc) Staged Heat	7-14	7-14	7-14	7-14	7-14	7-14	—	—	—
Natural Gas (in. wc) Modulating Heat	10-14	10-14	10-14	10-14	10-14	10-14	7-13.5	7-13.5	7.5-13.5
Liquid Propane (in. wc)	12-14	12-14	12-14	12-14	12-14	12-14	7-13.5	7-13.5	7.5-13.5
Connection Pipe sz/qty	3/4"/1	3/4"/2	3/4"/1	3/4"/2	3/4"/1	3/4"/2	1"/1	1-1/4"/1	1-1/4"/1
Manifold Pressure — Natural Gas (per gas valve)									
Stage 1 (in. wc)	1.2	1.2	1.2	1.2	1.2	1.2	N/A	N/A	N/A
Stage 2 (in. wc)	3.2	3.2	3.2	3.2	3.2	3.2	N/A	N/A	N/A
Modulating Low fire ²	0.4	0.4	0.4	0.4	0.4	0.4	N/A	N/A	N/A
Propane³									
Stage 1 (in. wc)	2.3	2.3	2.3	2.3	2.3	2.3	N/A	N/A	N/A
Stage 2 (in. wc)	10.0	10.0	10.0	10.0	10.0	10.0	N/A	N/A	N/A

Note: 1) Modulating gas heat only.

2) Modulating gas heat not available with propane.

3) See Table 7 on page 30 and Table 8 on page 31 for connection sizes.

4) Stainless steel heat exchanger only in 100% OA configuration only.

* Minimum airflow at full fire for 60°F temperature rise.

Pressure Drops

Table 13: Component Pressure Drops—MPS 015–050

Component	Unit	Unit Airflow (CFM)								
		4000	6000	8000	10,000	12,000	14,000	16,000	18,000	20,000
Economizer/ RA/OA	015–017	0.01	0.02	0.03	—	—	—	—	—	—
	020	0.01	0.02	0.03	0.05	—	—	—	—	—
	026–035	—	0.01	0.02	0.04	0.06	0.08	—	—	—
	040–050	—	—	0.01	0.02	0.03	0.04	0.05	0.06	0.08
Filter	015–017	0.04	0.09	0.16	—	—	—	—	—	—
	020	0.04	0.09	0.16	0.25	—	—	—	—	—
	026–035	0.02	0.04	0.07	0.11	0.16	0.21	—	—	—
	040	—	0.02	0.05	0.08	0.12	0.16	0.21	—	—
Cooling Coil	015–017	0.08	0.17	0.31	—	—	—	—	—	—
	020	0.08	0.17	0.31	0.50	—	—	—	—	—
	026–035	—	0.09	0.15	0.24	0.34	0.47	—	—	—
	040	—	—	0.14	0.22	0.32	0.45	0.58	—	—
Hot Gas Reheat	015–020	0.06	0.11	0.17	0.23	—	—	—	—	—
	026–035	—	0.07	0.10	0.14	0.19	0.23	—	—	—
	040–050	—	—	0.07	0.09	0.12	0.15	0.18	0.22	0.25
	050	—	—	0.04	0.06	0.08	0.11	0.15	0.19	0.23

Table 14: Gas Heat Pressure Drops—MPS 015–050

Unit	Heat Type	Unit Airflow (CFM)								
		4000	6000	8000	10,000	12,000	14,000	16,000	18,000	20,000
015–017	Low (240MBH)	0.08	0.19	0.33	—	—	—	—	—	—
	High (480 MBH)	0.14	0.31	0.55	—	—	—	—	—	—
020	Low (240MBH)	—	0.19	0.33	0.52	0.74	—	—	—	—
	High (480 MBH)	—	0.31	0.55	0.86	1.24	—	—	—	—
026–035	Low (300MBH)	—	—	0.10	0.16	0.23	0.31	—	—	—
	High (600 MBH)	—	—	0.18	0.28	0.41	0.56	—	—	—
040–050	Low (400 MBH)	—	—	0.04	0.07	0.10	0.14	0.18	0.23	0.28
	High (800 MBH)	—	—	0.11	0.18	0.26	0.35	0.46	0.58	0.71

Table 15: High Temperature Furnace Airside Pressure Drops

Unit	4000	6000	8000	10,000	12,000	14,000
015–017	0.14	0.31	—	—	—	—
020	0.14	0.31	0.55	—	—	—
026–035	0.13	0.29	0.53	0.83	—	—
040–050	—	0.26	0.45	0.69	0.98	1.32

Table 16: Hot Water Pressure Drops—MPS 015–050

Unit	Heat Type	Unit Airflow (CFM)								
		4000	6000	8000	10,000	12,000	14,000	16,000	18,000	20,000
015–017	015–017 Low (1 row)	0.09	0.17	0.27	—	—	—	—	—	—
	015–017 High (2 row)	0.17	0.34	0.68	—	—	—	—	—	—
020	020–025 Low (1 row)	—	0.20	0.32	0.52	—	—	—	—	—
	020–025 High (2 row)	—	0.28	0.46	0.98	—	—	—	—	—
026–035	030–035 Low (1 row)	—	—	0.14	0.20	0.27	0.35	—	—	—
	030–035 High (2 row)	—	—	0.23	0.33	0.46	0.59	—	—	—
040–050	040–050 Low (1 row)	—	—	—	0.19	0.26	0.34	0.42	0.51	0.61
	040–050 High (2 row)	—	—	—	0.40	0.54	0.69	0.86	1.05	1.25

Table 17: Electric Heat Pressure Drops—MPS 015–050

Unit	Unit Airflow (CFM)								
	4000	6000	8000	10,000	12,000	14,000	16,000	18,000	20,000
015–017	0.05	0.11	0.20	—	—	—	—	—	—
020	0.05	0.11	0.20	0.31	—	—	—	—	—
026–035	—	0.05	0.10	0.15	0.22	0.30	0.39	—	—
040–050	—	—	0.05	0.08	0.11	0.15	0.19	0.24	0.30

Table 18: Component Pressure Drops—MPS 061–075

Component		Airflow (cfm)								
		14,000	16,000	18,000	20,000	22,000	24,000	26,000	28,000	30,000
Outdoor/ return air options ¹	0–30% outside air hood w/damper	0.06	0.08	0.10	0.12	0.15	0.18	0.21	0.24	0.28
	100% outside air hood w/damper	0.01	0.02	0.02	0.03	0.03	0.04	0.05	0.05	0.06
	0–100% economizer, w/o RAF	0.08	0.10	0.13	0.16	0.19	0.23	0.27	0.31	0.36
Filter options	30% pleated	0.08	0.10	0.12	0.14	0.16	0.18	0.20	0.25	0.27
	Prefilter, standard flow	0.17	0.20	0.24	0.28	0.32	0.37	0.41	—	—
	Prefilter, medium flow	0.13	0.15	0.18	0.21	0.25	0.28	0.32	0.35	0.39
	65% cartridge, standard flow	0.27	0.34	0.41	0.49	0.57	0.66	0.76	—	—
	65% cartridge, medium flow	0.20	0.25	0.31	0.36	0.43	0.49	0.56	0.63	0.71
	95% cartridge, standard flow	0.38	0.46	0.55	0.64	0.74	0.84	0.95	—	—
Cooling options ²	DX, standard airflow, 5–row, 10 fpi	0.41	0.50	0.59	0.69	0.79	0.89	—	—	—
	DX, high airflow, 5–row, 10 fpi	—	0.38	0.45	0.52	0.60	0.68	0.79	0.88	0.98
Heating options	Hot water, 1–row	0.12	0.15	0.19	0.22	0.26	0.30	0.35	0.39	0.44
	Hot water, 2–row	0.24	0.30	0.37	0.44	0.52	0.61	0.69	0.78	0.88
	Electric heat	0.07	0.10	0.12	0.15	0.18	0.22	0.25	0.29	0.34
Furnace	Low heat	0.10	0.13	0.17	0.21	0.25	0.30	0.35	0.41	0.47
	Medium heat	0.21	0.12	0.16	0.20	0.24	0.28	0.33	0.38	0.44
	High heat	0.10	0.12	0.16	0.20	0.24	0.28	0.33	0.38	0.44

Note: 1) Pressure drop is based on 30% of listed airflow.

2) DX coil pressure drops are based on wet coils. Standard air flow coil not applicable on sizes 070E–075E.

Table 19: Pressure Drop—Standard Airflow Energy Wheel

Cabinet	Wheel Diameter	1,000	2,000	3,000	4,000	5,000	6,000	7,000
15–20	46	0.30	0.60	0.89	—	—	—	—
26–35	52	0.18	0.33	0.48	0.62	0.76	—	—
40–50	64	0.15	0.30	0.45	0.60	0.75	0.90	1.32

Table 20: Pressure Drop—High Airflow Energy Wheel

Cabinet	Wheel Diameter	2,000	3,000	4,000	5,000	6,000	7,000	8,000	9,000	10,000	11,000
15–20	52	0.33	0.48	0.62	0.76	—	—	—	—	—	—
26–35	64	0.30	0.45	0.60	0.75	0.90	1.05	1.20	—	—	—
40–50	74	0.18	0.27	0.34	0.42	0.50	0.57	0.65	0.72	0.79	0.87

Table 21: Pressure Drop—Standard Airflow Energy Wheel Filter

Cabinet	1,000	2,000	3,000	4,000	5,000	6,000	7,000
15–20	0.01	0.01	0.02	0.03	—	—	—
26–35	0.01	0.03	0.08	0.14	0.22	—	—
40–50	0.01	0.02	0.03	0.06	0.10	0.14	0.19

Table 22: Pressure Drop—High Airflow Energy Wheel Filter

Cabinet	2,000	3,000	4,000	5,000	6,000	7,000	8,000	9,000	10,000	11,000
15–20	0.03	0.08	0.14	0.22	0.31	0.42	0.55	0.70	0.87	1.05
26–35	0.02	0.04	0.08	0.12	0.18	0.24	0.31	0.40	0.49	0.59
40–50	0.01	0.02	0.03	0.05	0.08	0.11	0.14	0.18	0.22	0.26

Table 23: Pressure Drop—Energy Wheel Back Draft Damper

Cabinet	2,000	3,000	4,000	5,000	6,000	7,000	8,000	9,000	10,000	11,000
15–20	0.01	0.03	0.04	0.07	0.09	0.12	0.16	0.20	0.24	0.29
26–35	0.01	0.03	0.04	0.07	0.09	0.12	0.16	0.20	0.24	0.29
40–50	0.01	0.01	0.02	0.04	0.05	0.07	0.09	0.11	0.14	0.17

Hot Water Low/High Heat Curves

Figure 19: MPS 015–017 Low Heat

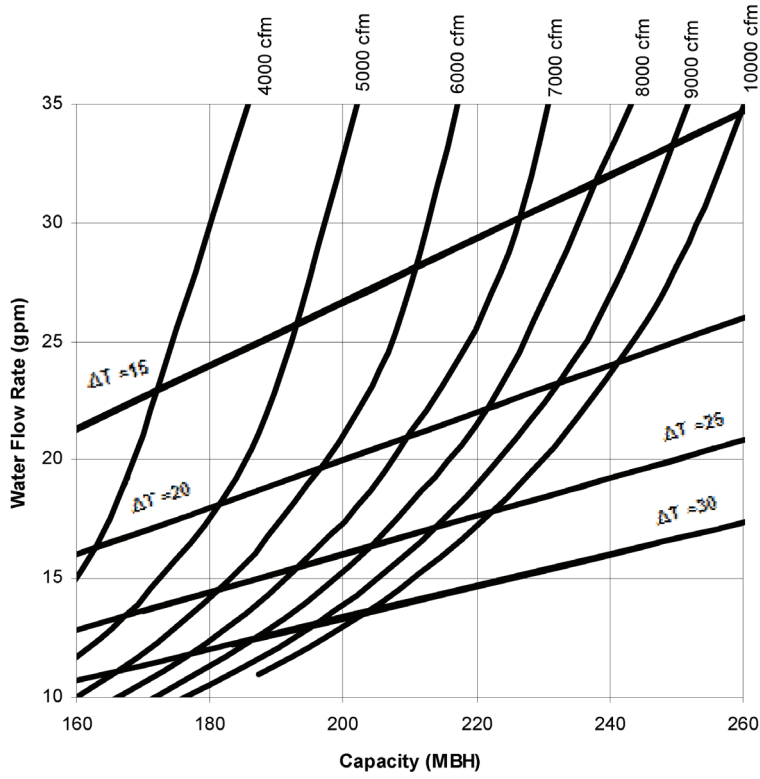

Figure 20: MPS 015–017 High Heat

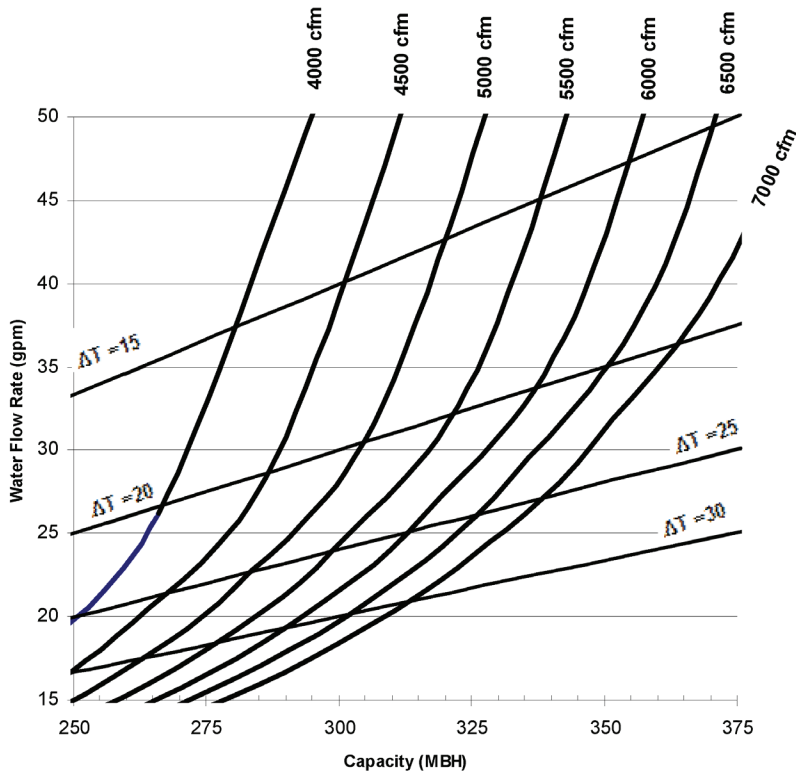

Figure 21: MPS 020 Low Heat

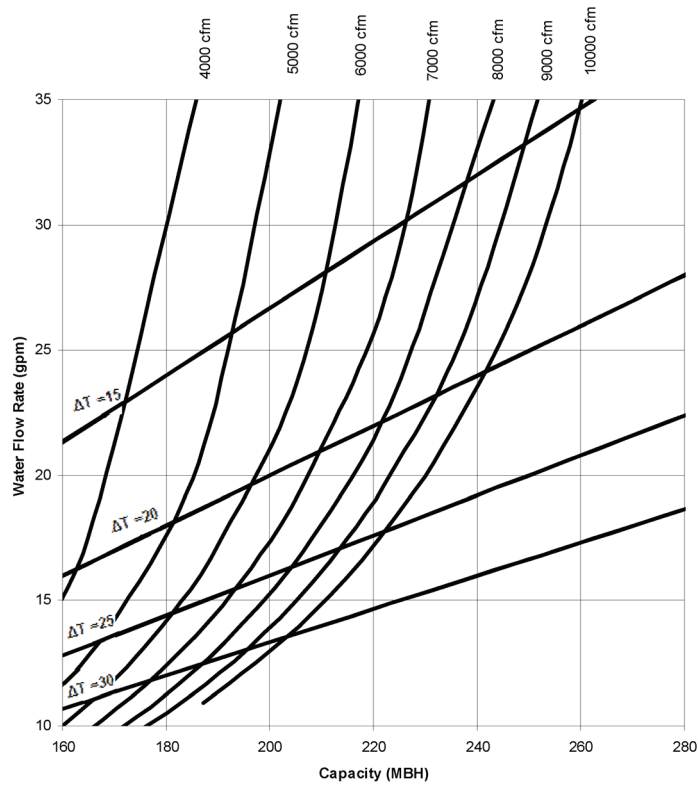

Figure 22: MPS 020 High Heat

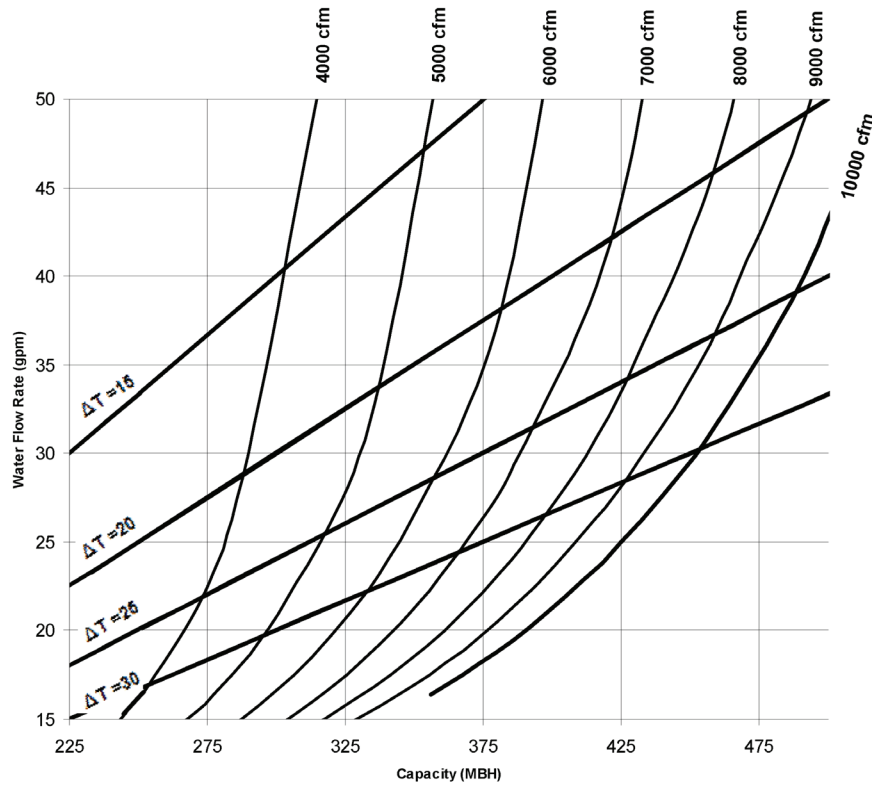

Figure 23: MPS 026–035 Low Heat

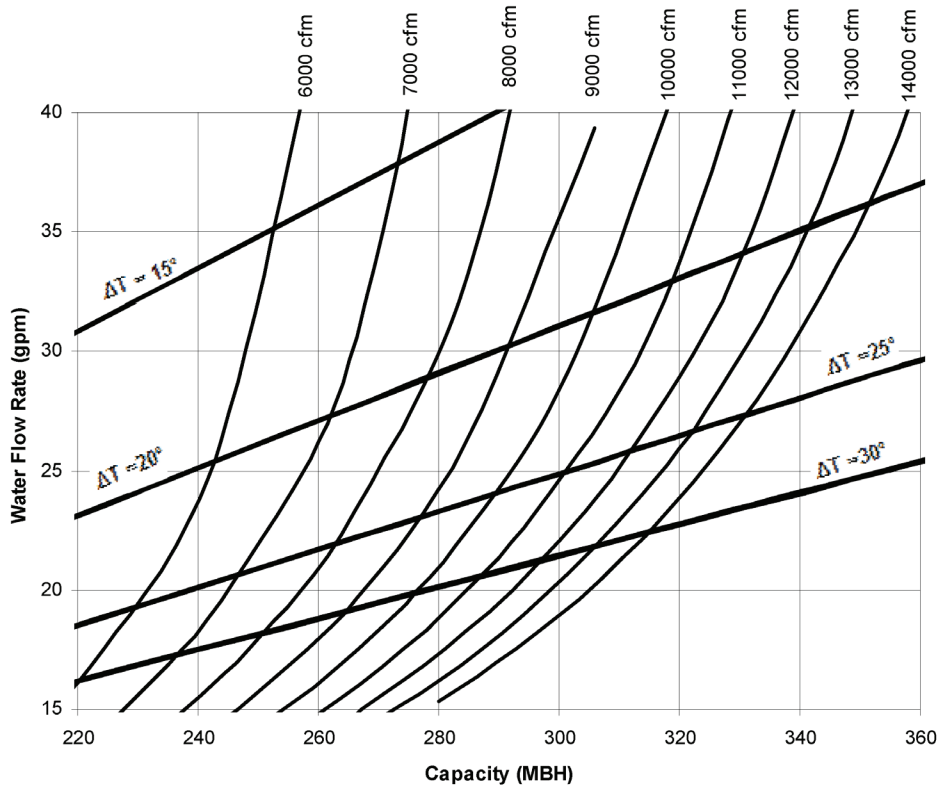

Figure 24: MPS 026–035 High Heat

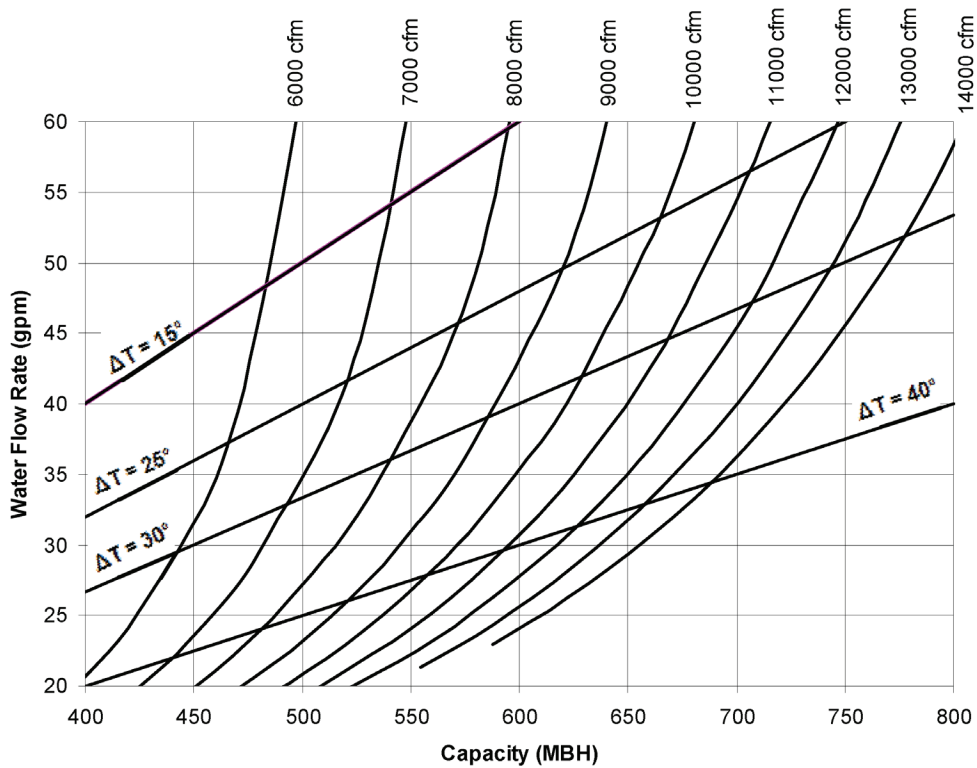

Figure 25: MPS 040-050 Low Heat

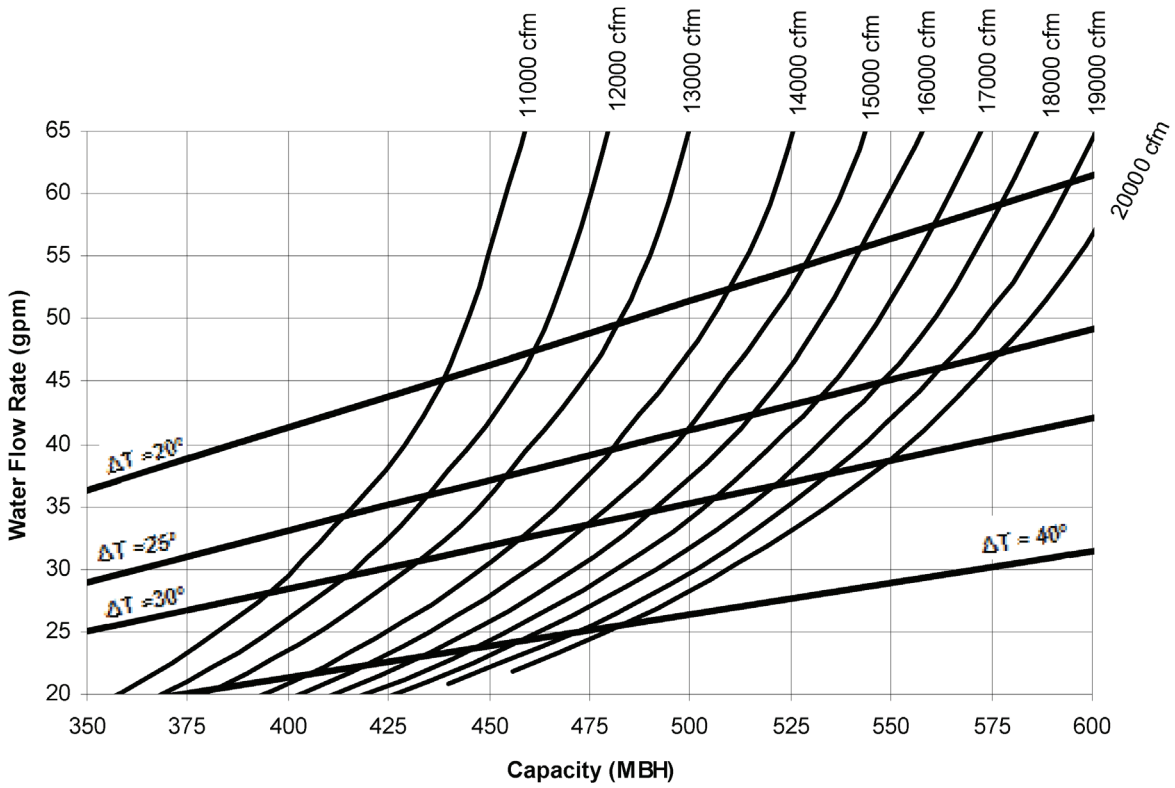

Figure 26: MPS 040-050 High Heat

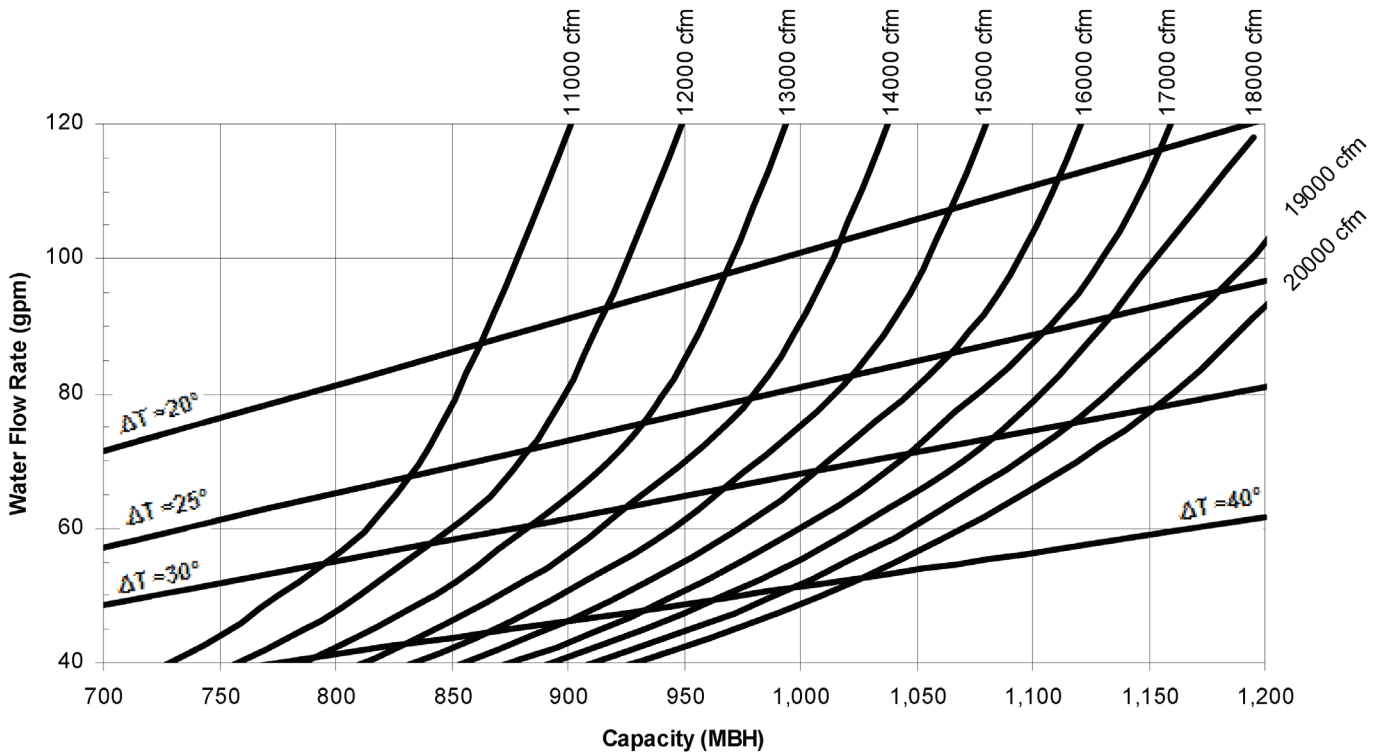

Figure 27: MPS 061-075 Standard Heat

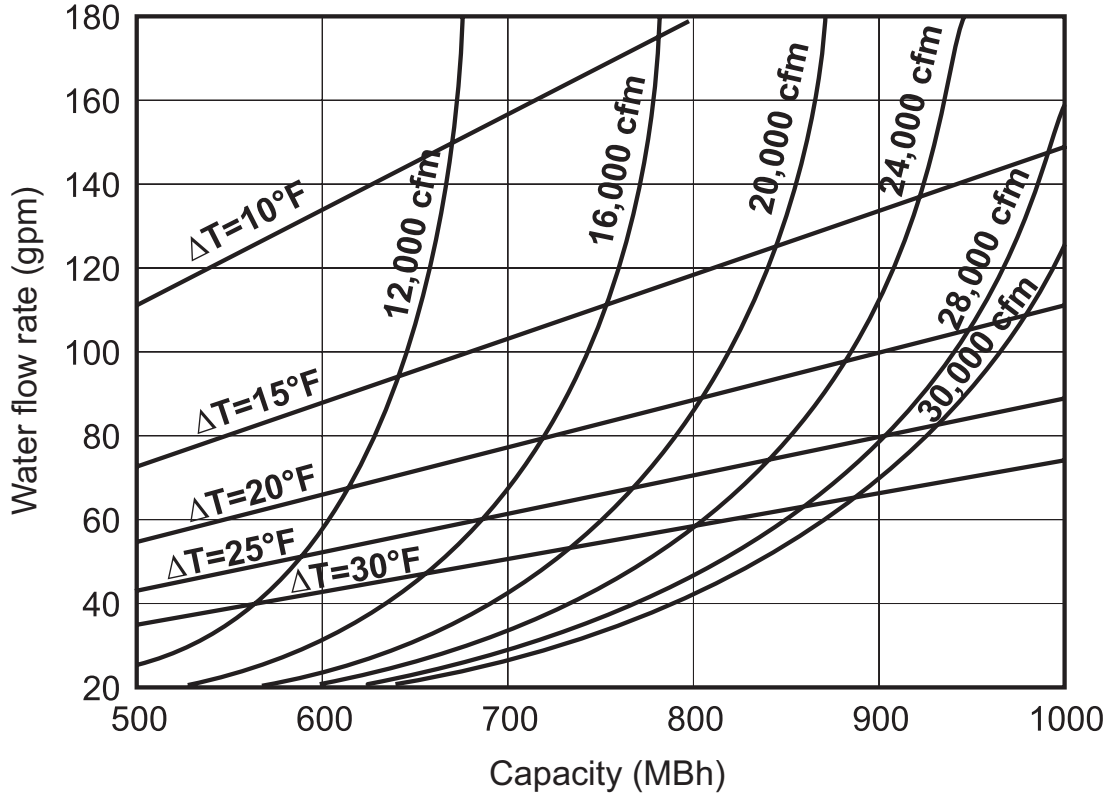
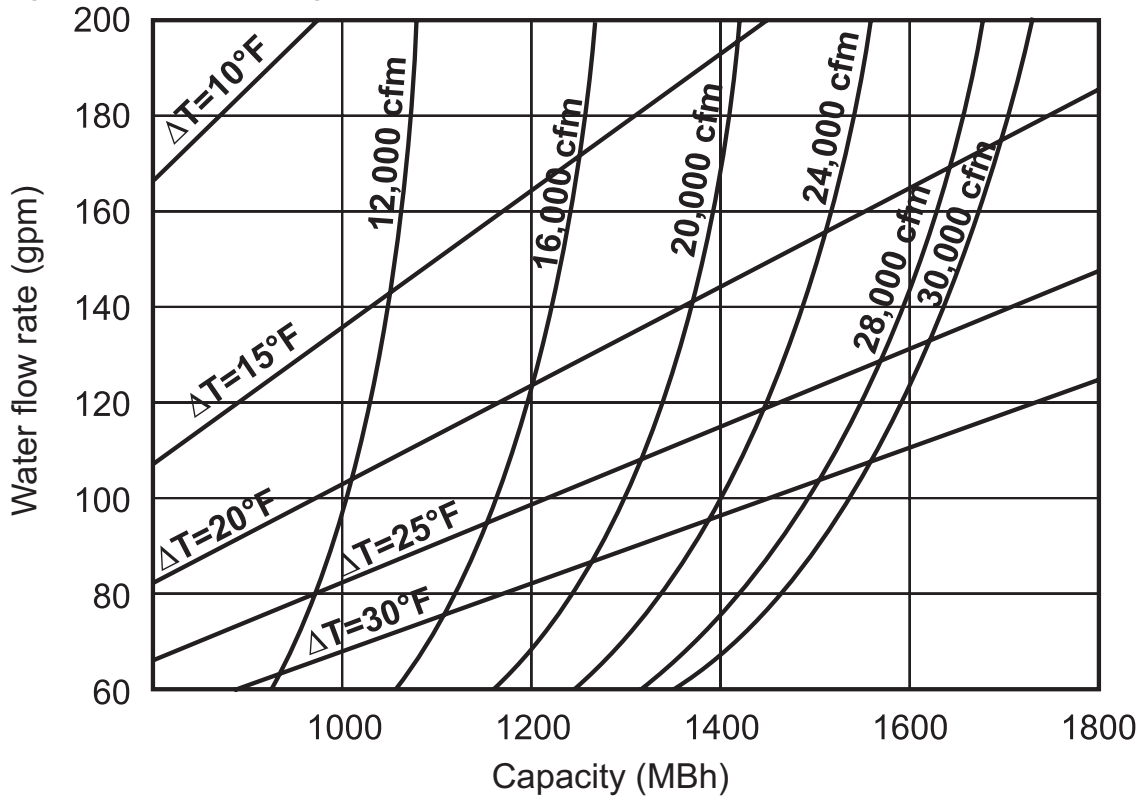

Figure 28: MPS 061-075 High Heat



Hot Water Pressure Drop Curves

Figure 29: MPS 015-017 Pressure Drop

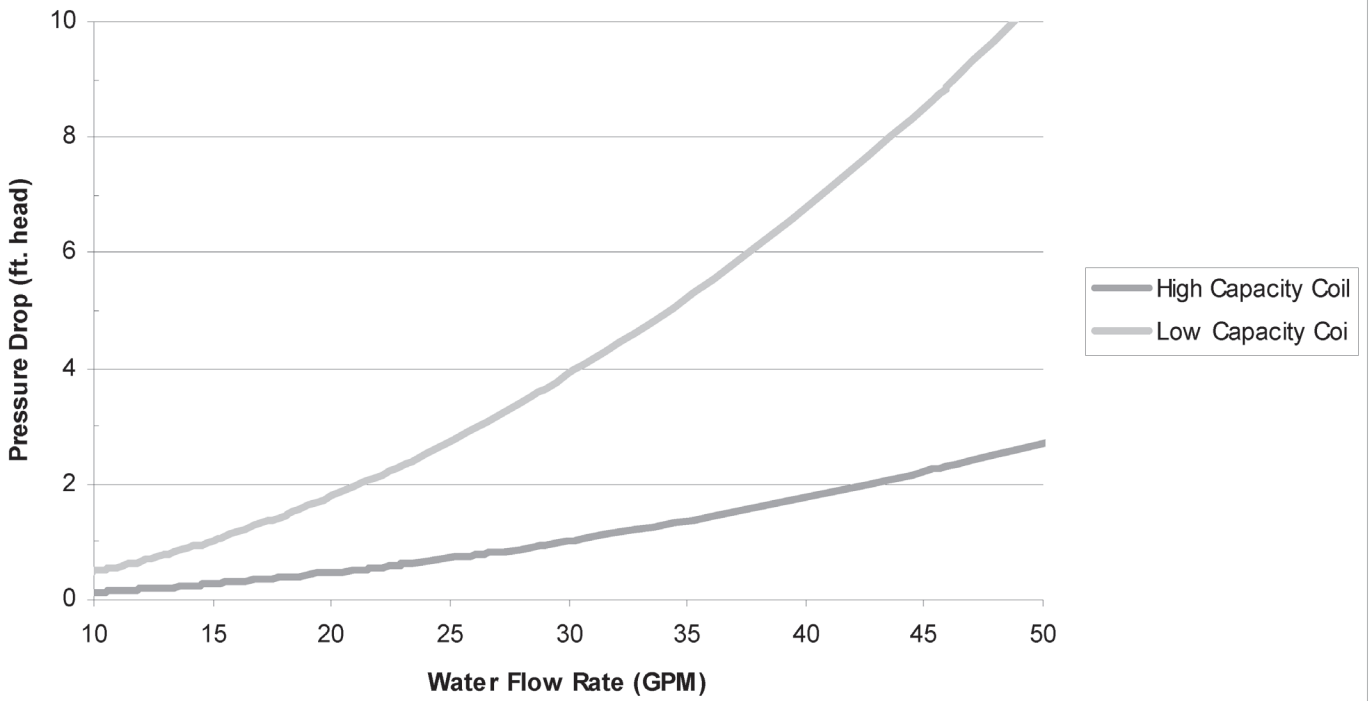

Figure 30: MPS 020 Pressure Drop

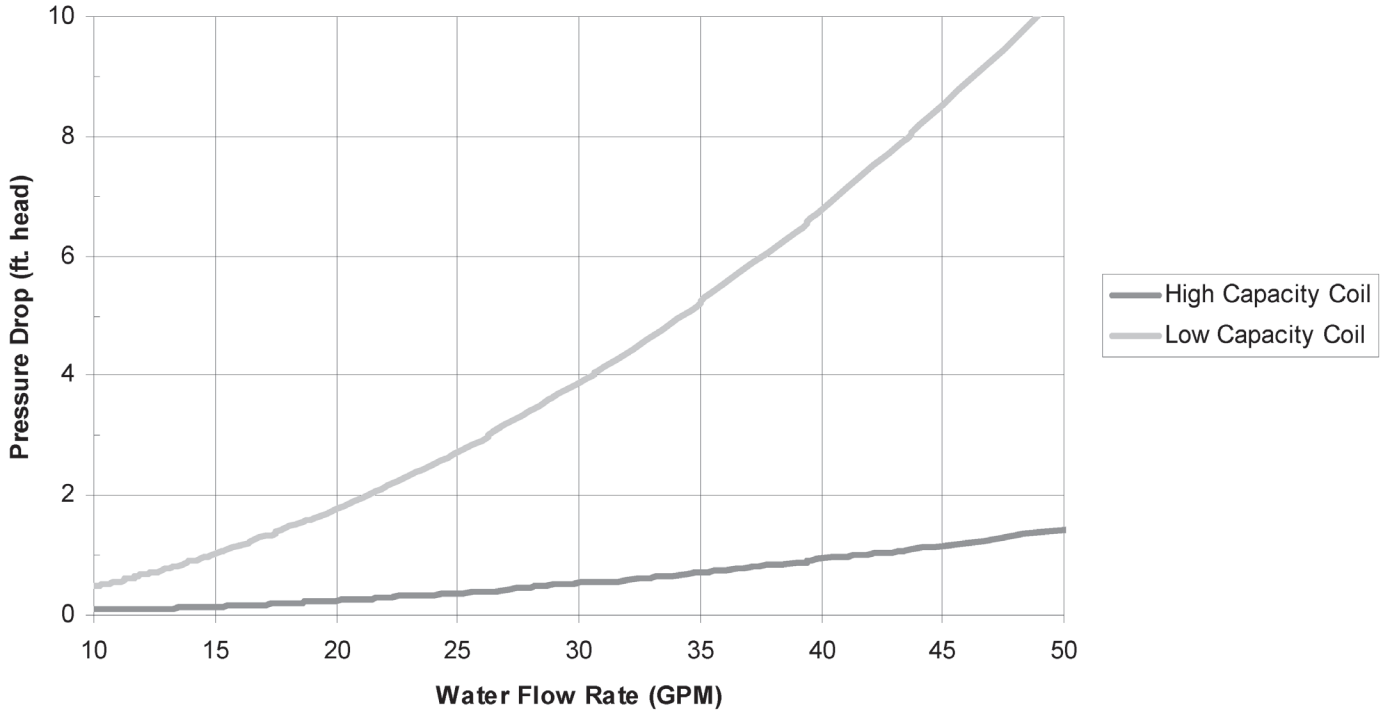

Figure 31: MPS 026–035 Pressure Drop

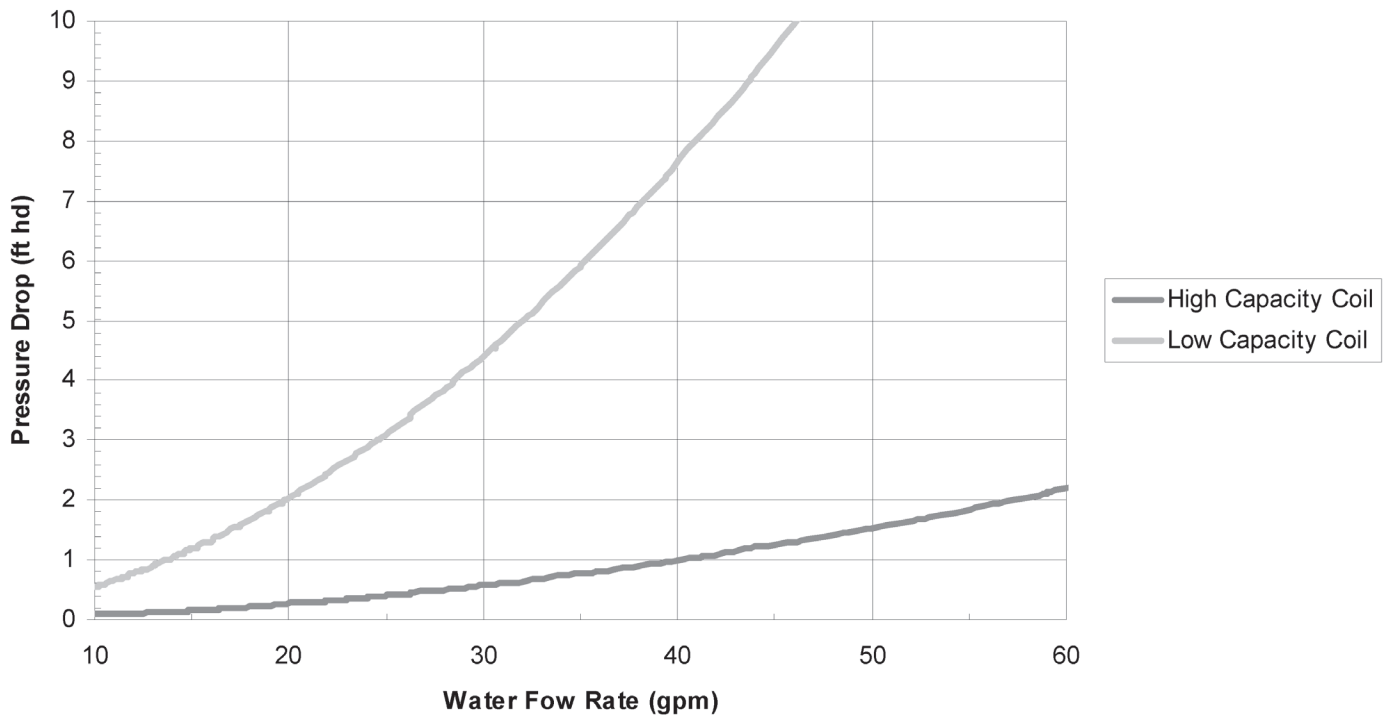

Figure 32: MPS 040–050 Pressure Drop

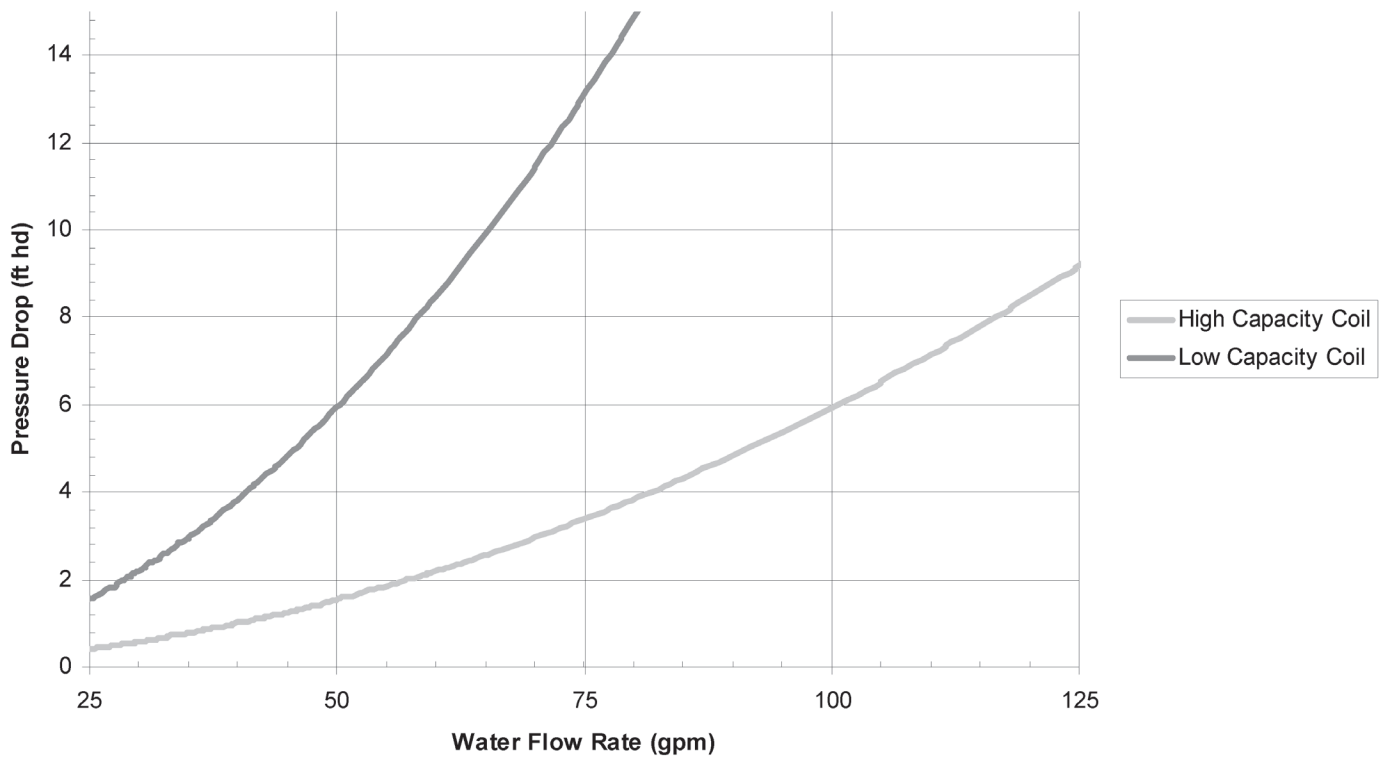
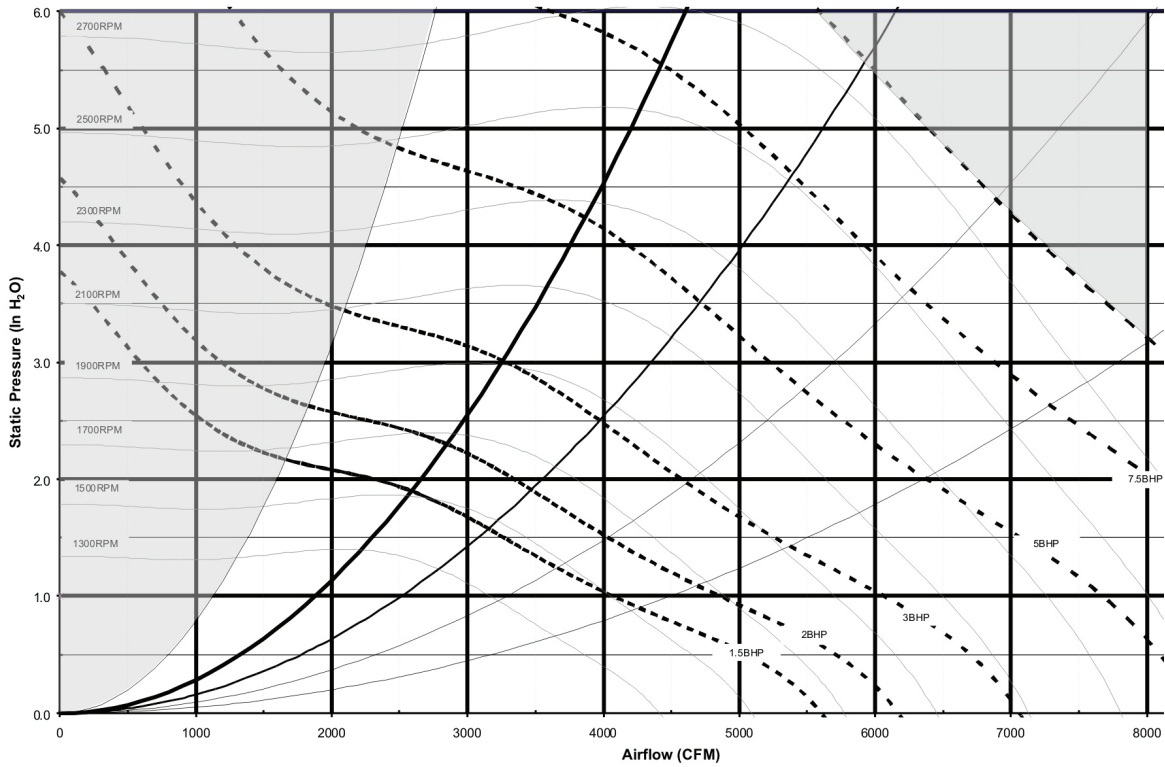

Table 24: Supply Fan Matrix

Cabinet	Standard (in.)	100% OA (in.)	100% with Energy Recovery (in.)	Energy Recovery with Economizer (in.)
15 ton	18	15	15	18
17 ton	20	15	15	20
20 ton	22	18	18	22
26 ton	24	22	22	24
35 ton	24	22	22	24
40 ton	30	24	30	30
50 ton	30	24	30	30

Figure 33: 18" SWSI Airfoil Supply Fan



Supply Fan Performance

Figure 34: 20-in. SWSI Airfoil Supply Fan

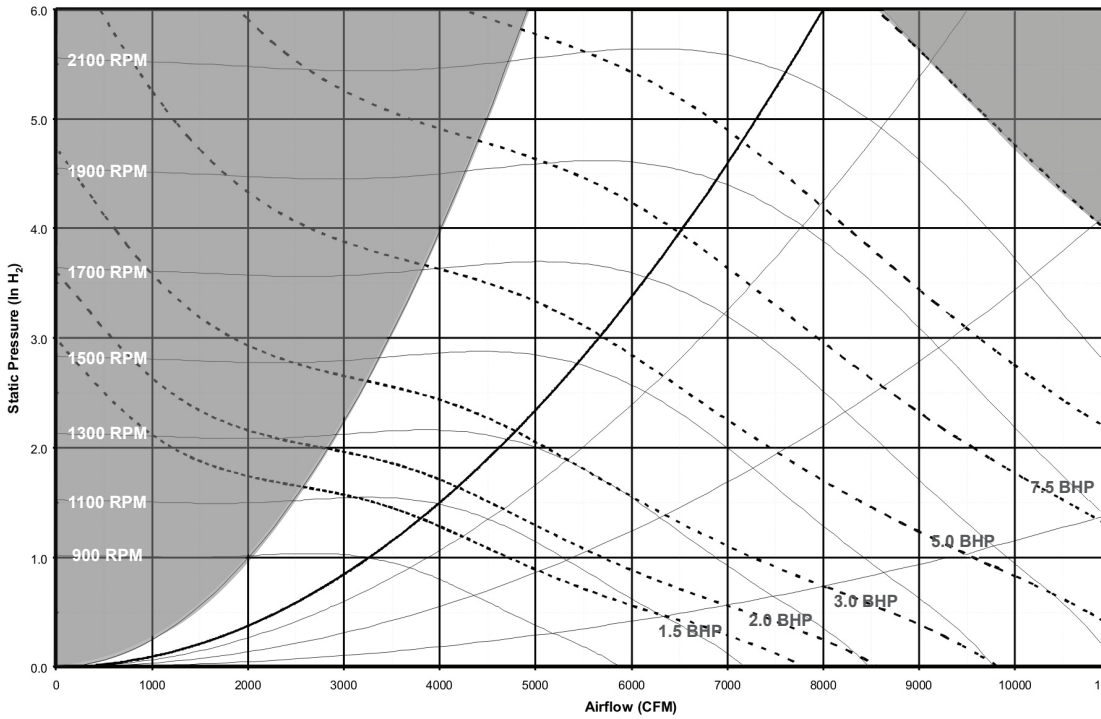

Figure 35: 22-in. SWSI Airfoil Supply Fan

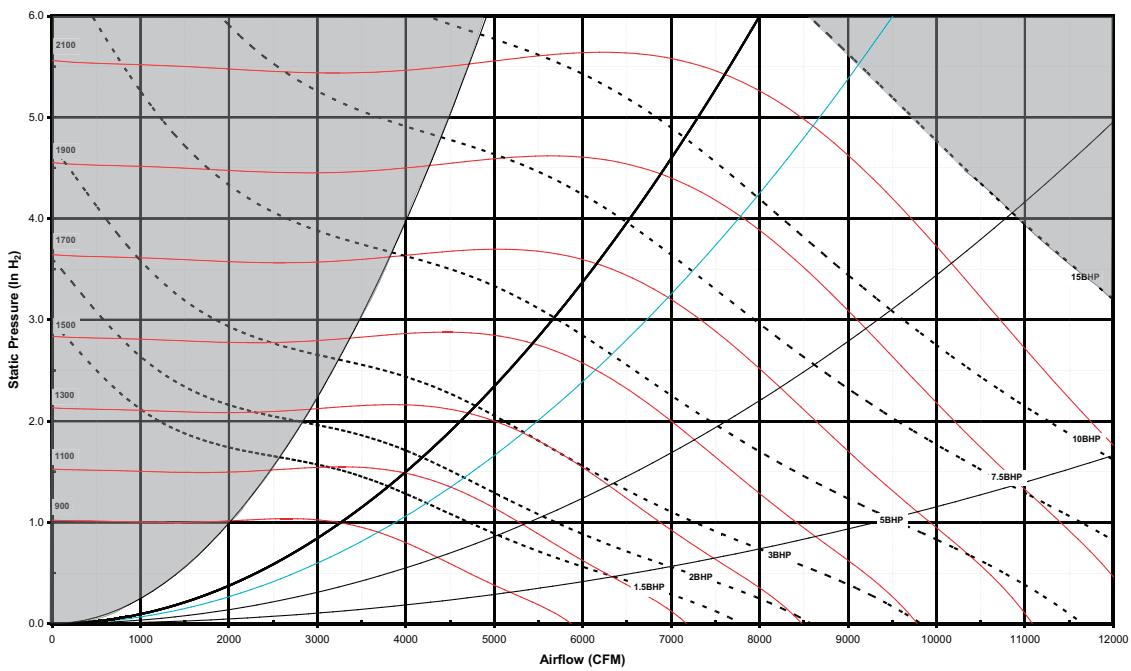

Figure 36: 24-in. SWSI Airfoil Supply Fan

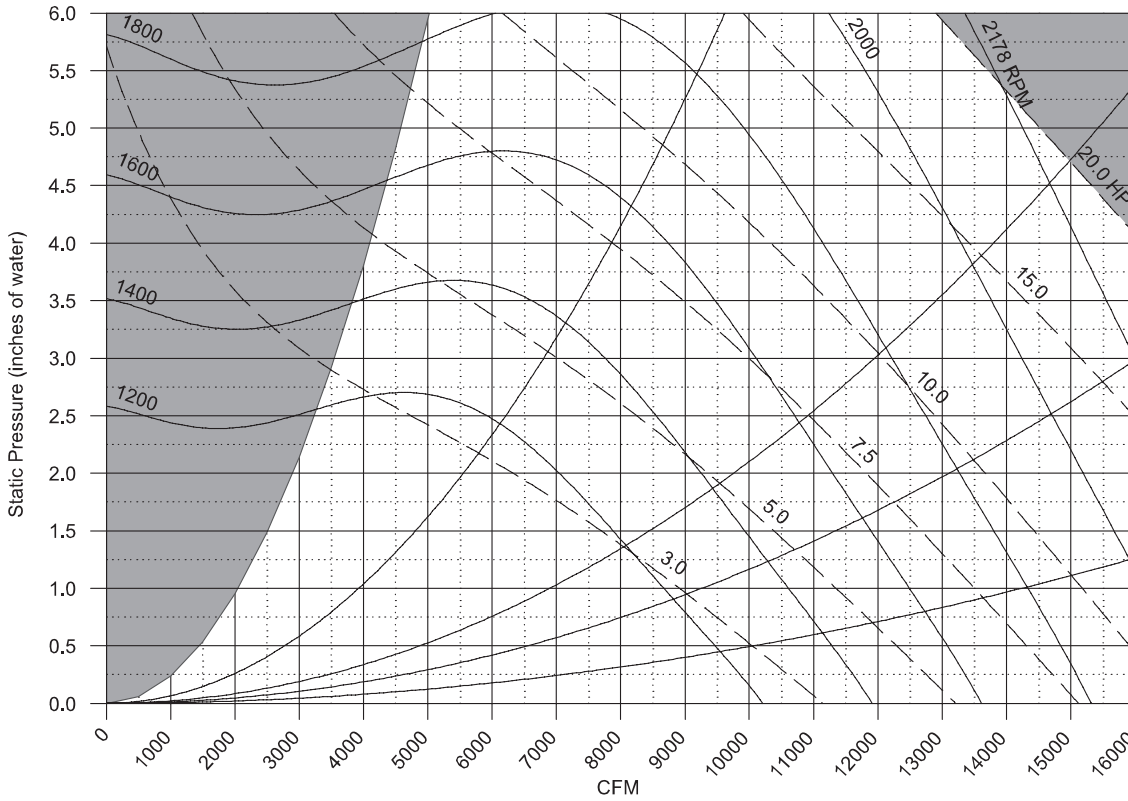

Figure 37: 30-in. SWSI Airfoil Supply Fan

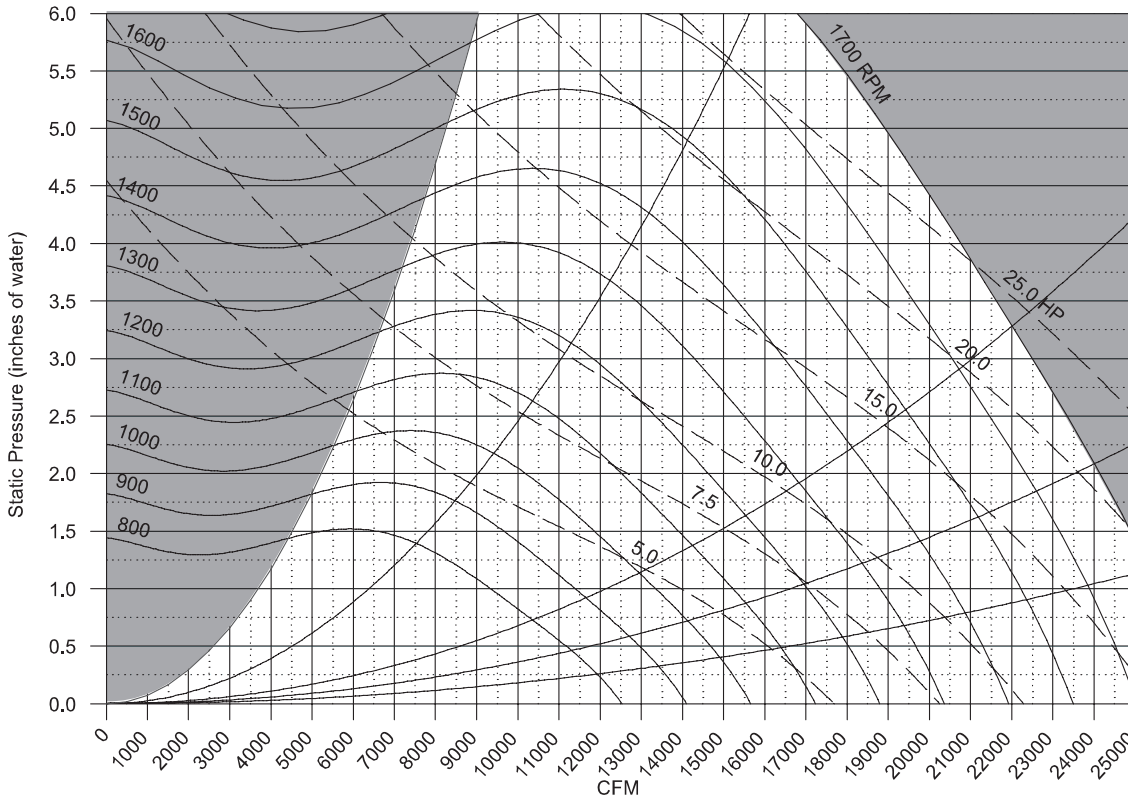

Figure 38: MPS 061-075 40-in. Standard Fan, SWSI Airfoil Supply Fan, Cooling Only or Hot Water

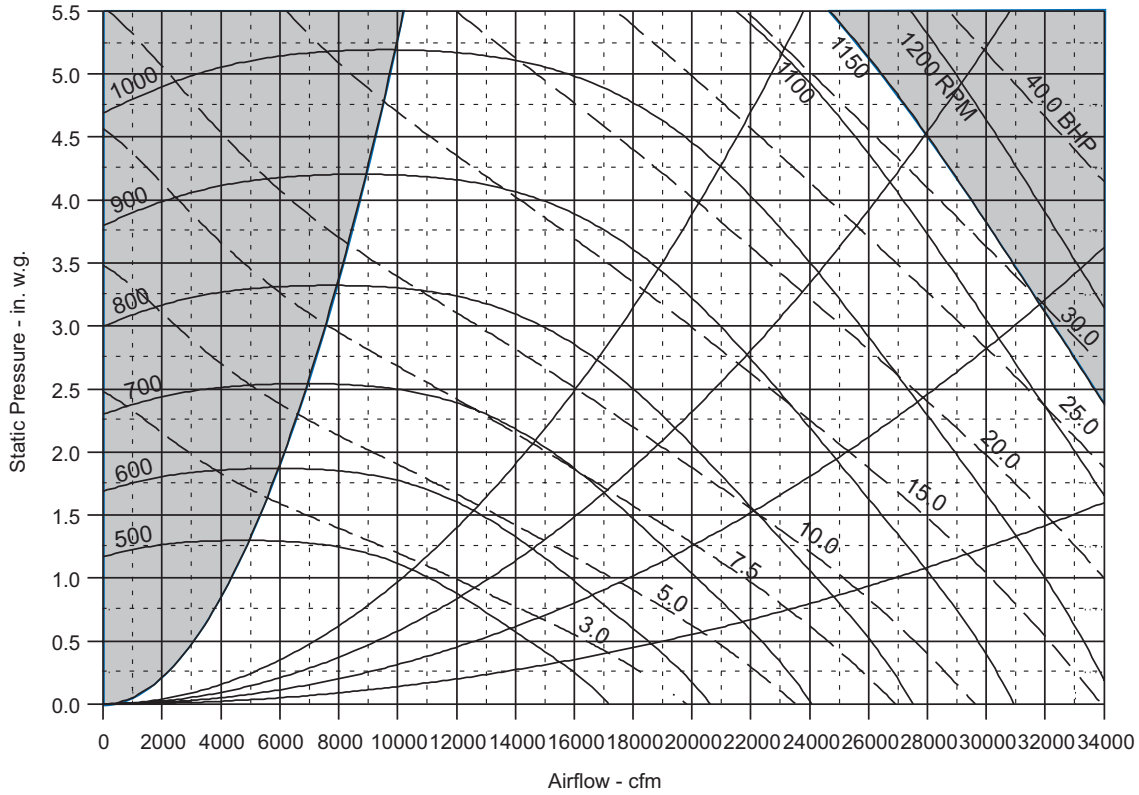

Figure 39: MPS 061-075 44-in. Large Fan, SWSI Airfoil Supply Fan, Cooling Only or Hot Water

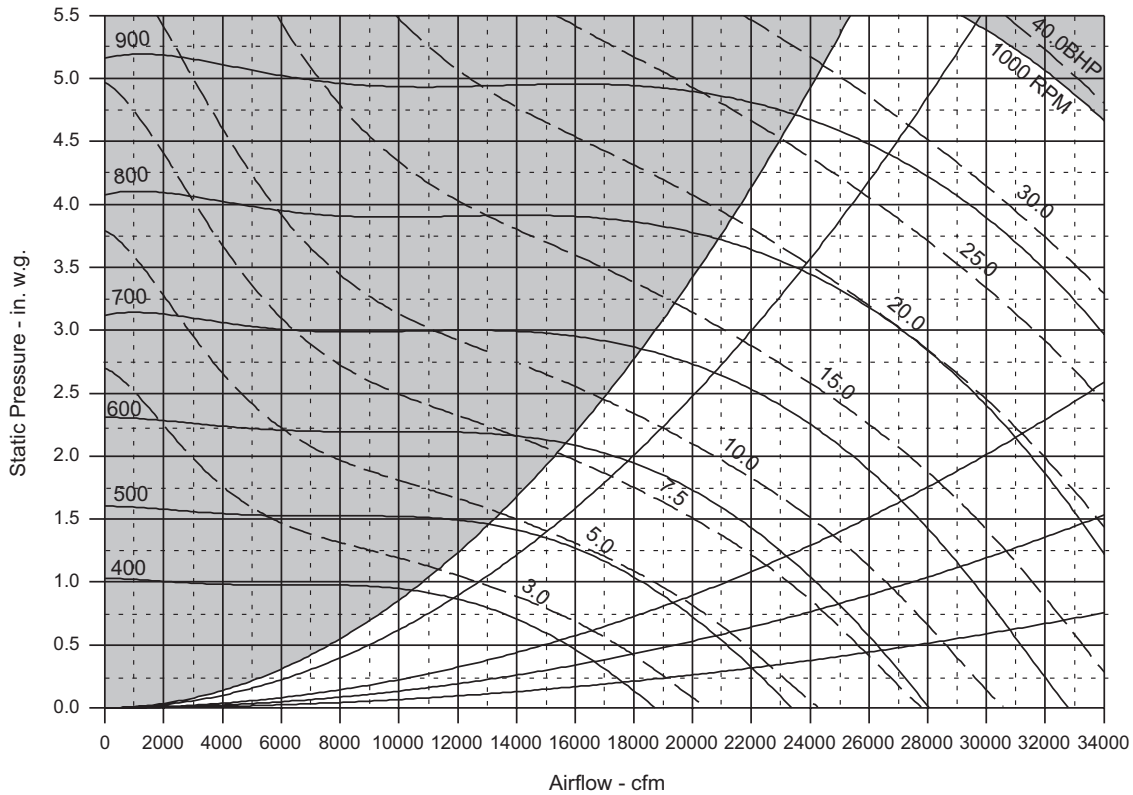

Figure 40: MPS 061–075 30-in. Standard Fan, DWDI Airfoil Supply Fan

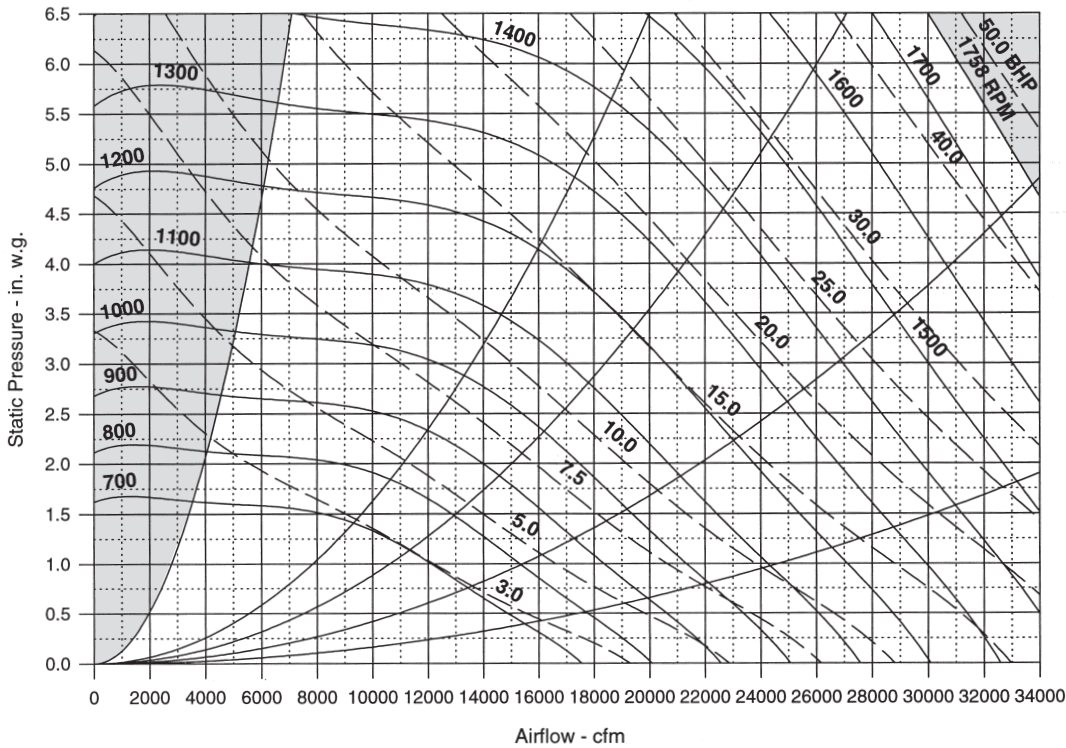
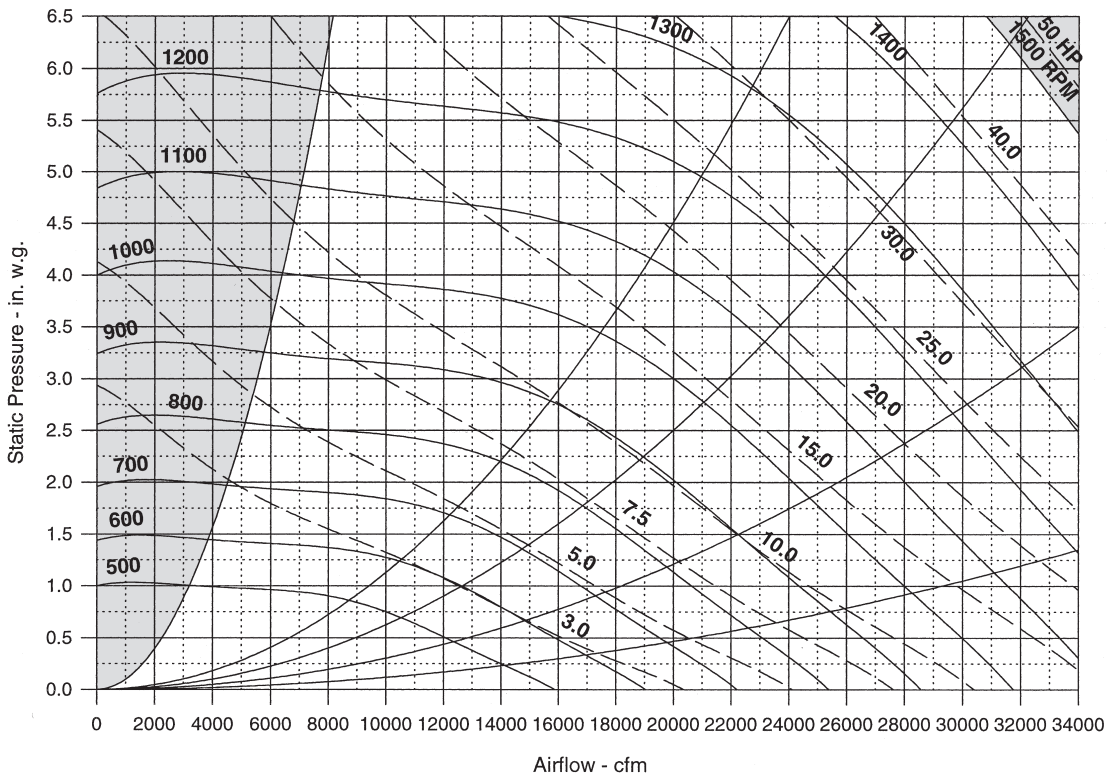

Figure 41: MPS 061–075 Large Fan, 33-in. Standard Fan, DWDI Airfoil Supply Fan, Gas or Electric Heat



NOTE: Maximum allowable static pressure at fan bulkhead is 5.0 in. (i.e., supply duct ESP cannot exceed 5.0 in).

Figure 42: 18-in. Energy Recovery SWSI Air Foil Exhaust Fan Curve

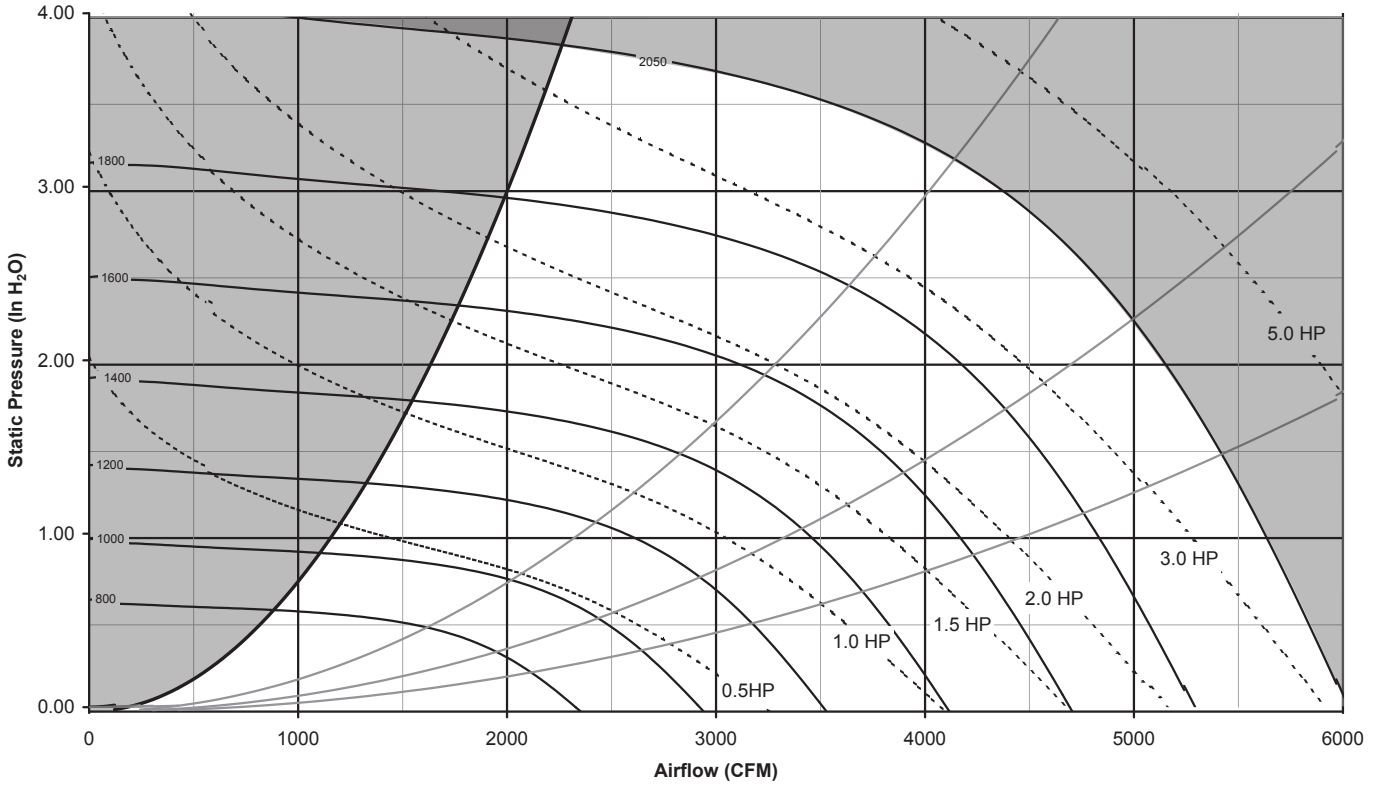

Figure 43: 22-in. Energy Recovery SWSI Air Foil Exhaust Fan Curve

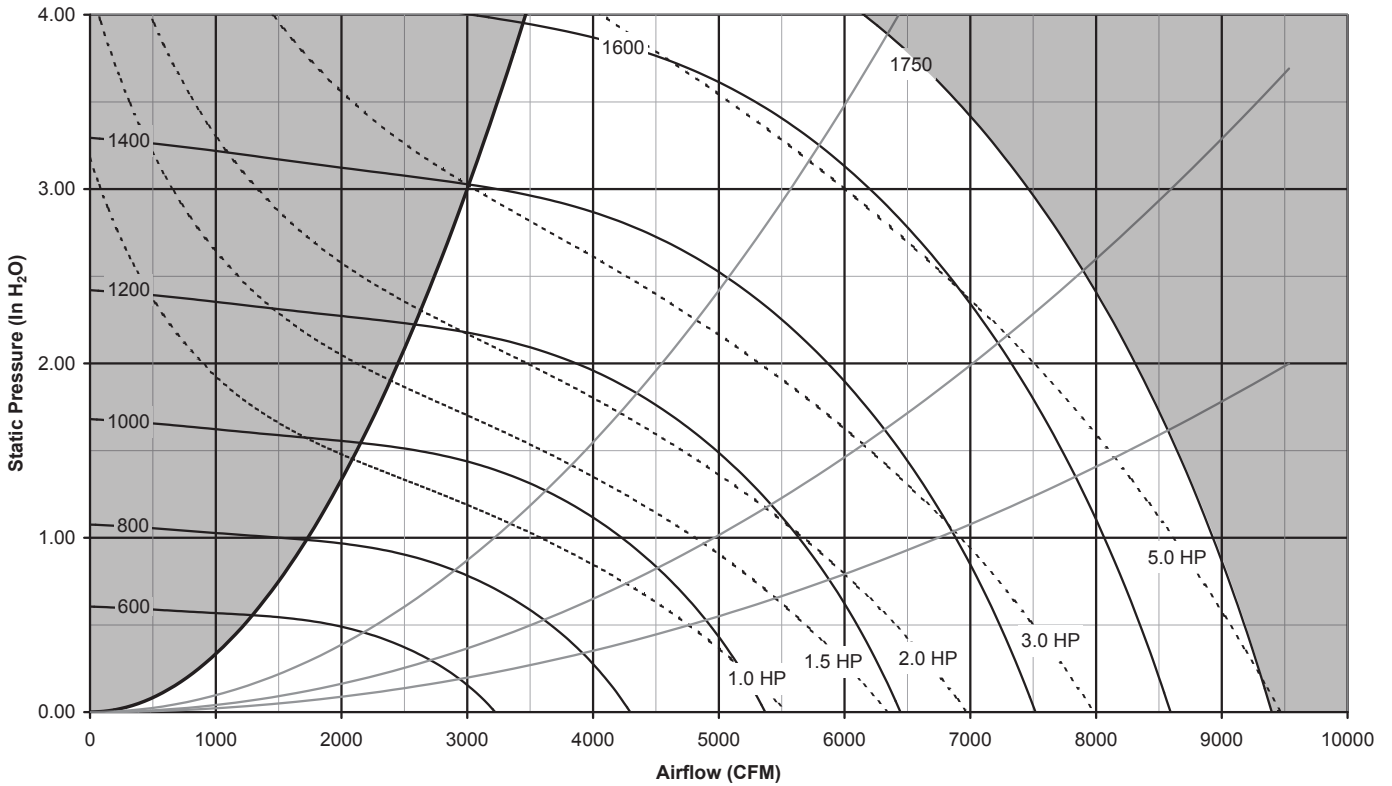

Figure 44: Energy Recovery Dual SWSI Air Foil Dual 18-in. Exhaust Fan Curve

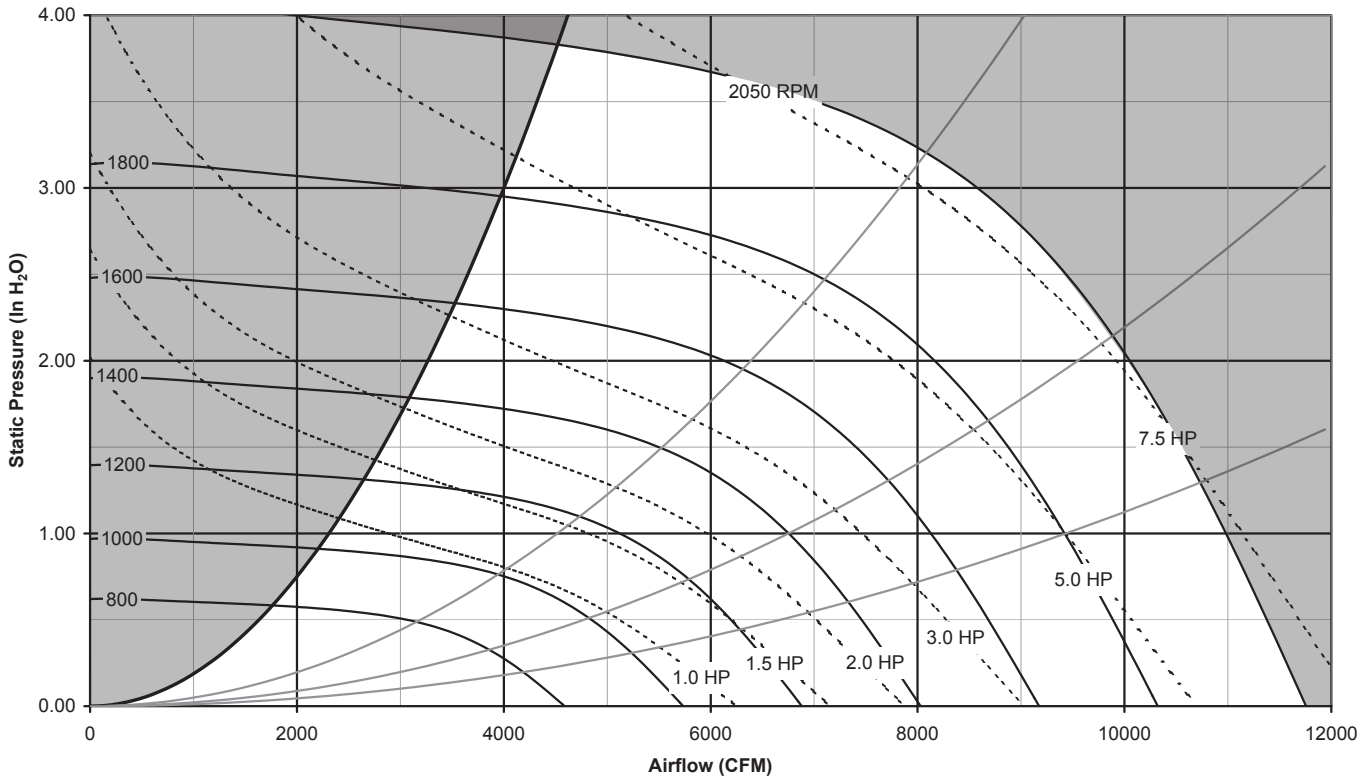
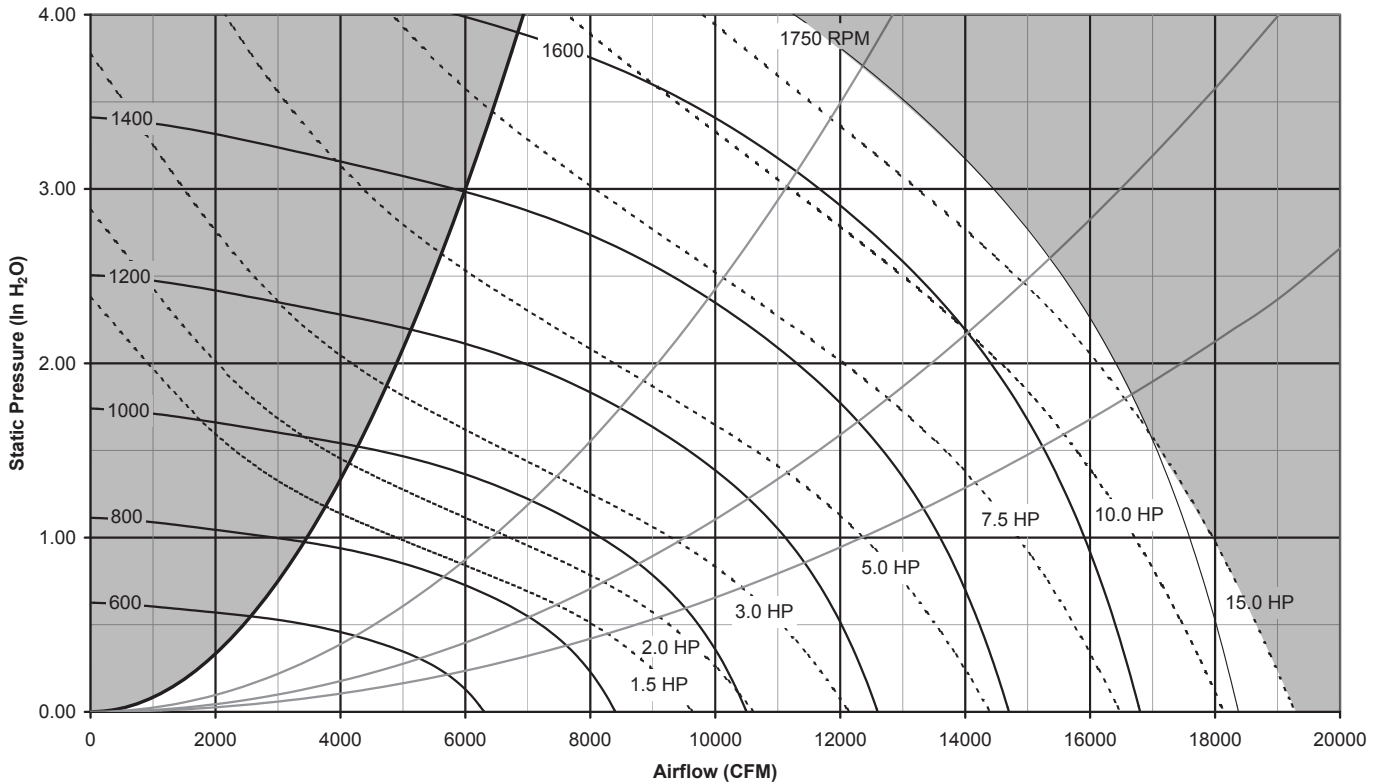

Figure 45: Energy Recovery Dual SWSI Air Foil Dual 22-in. Exhaust Fan Curve



Dimensional Data

MPS 015–020 Unit Dimensions

Figure 46: MPS 015–020 Cooling/Electric Heating Unit

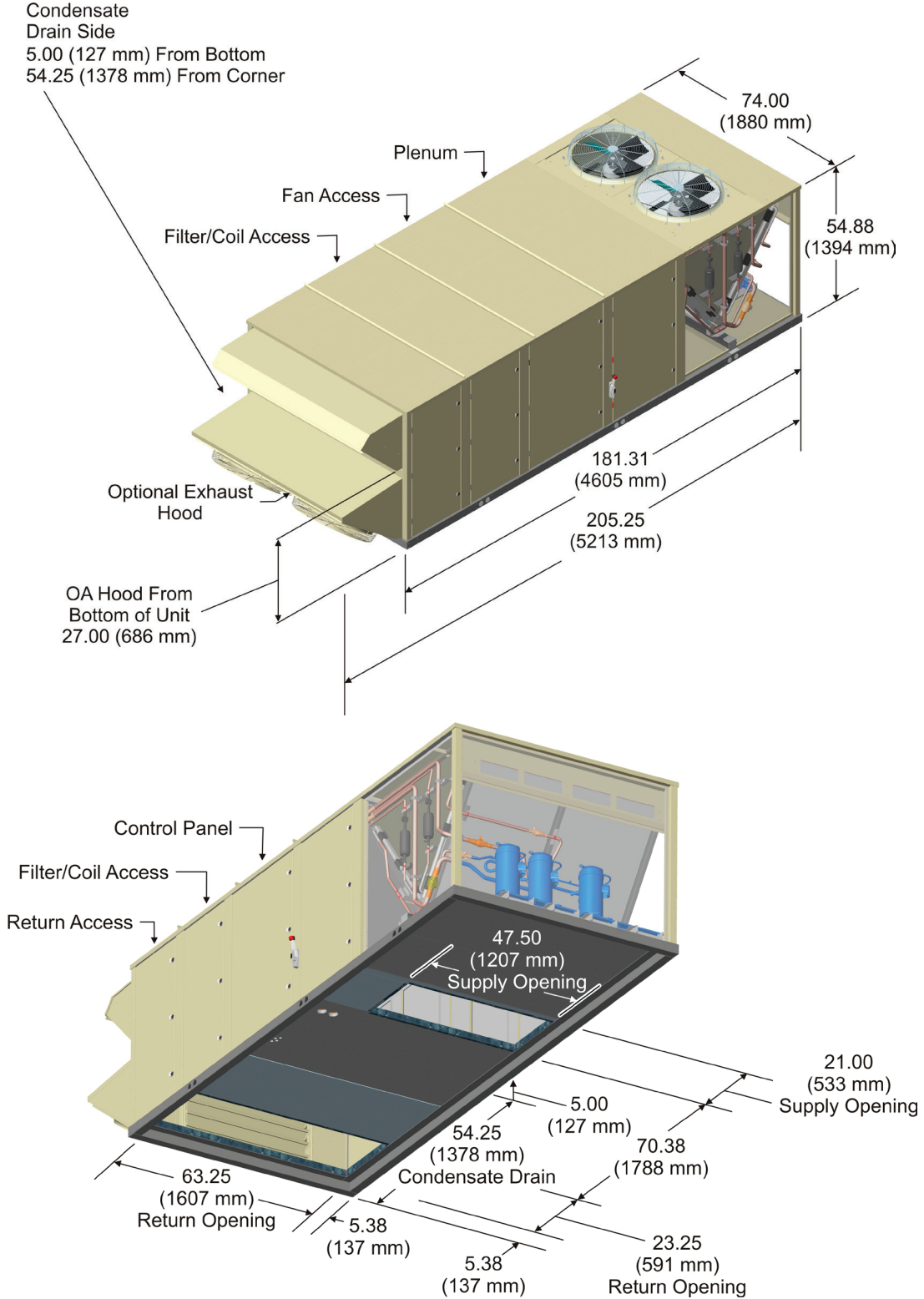

Figure 47: MPS 015-020 Cooling/Hot Water Heating Unit

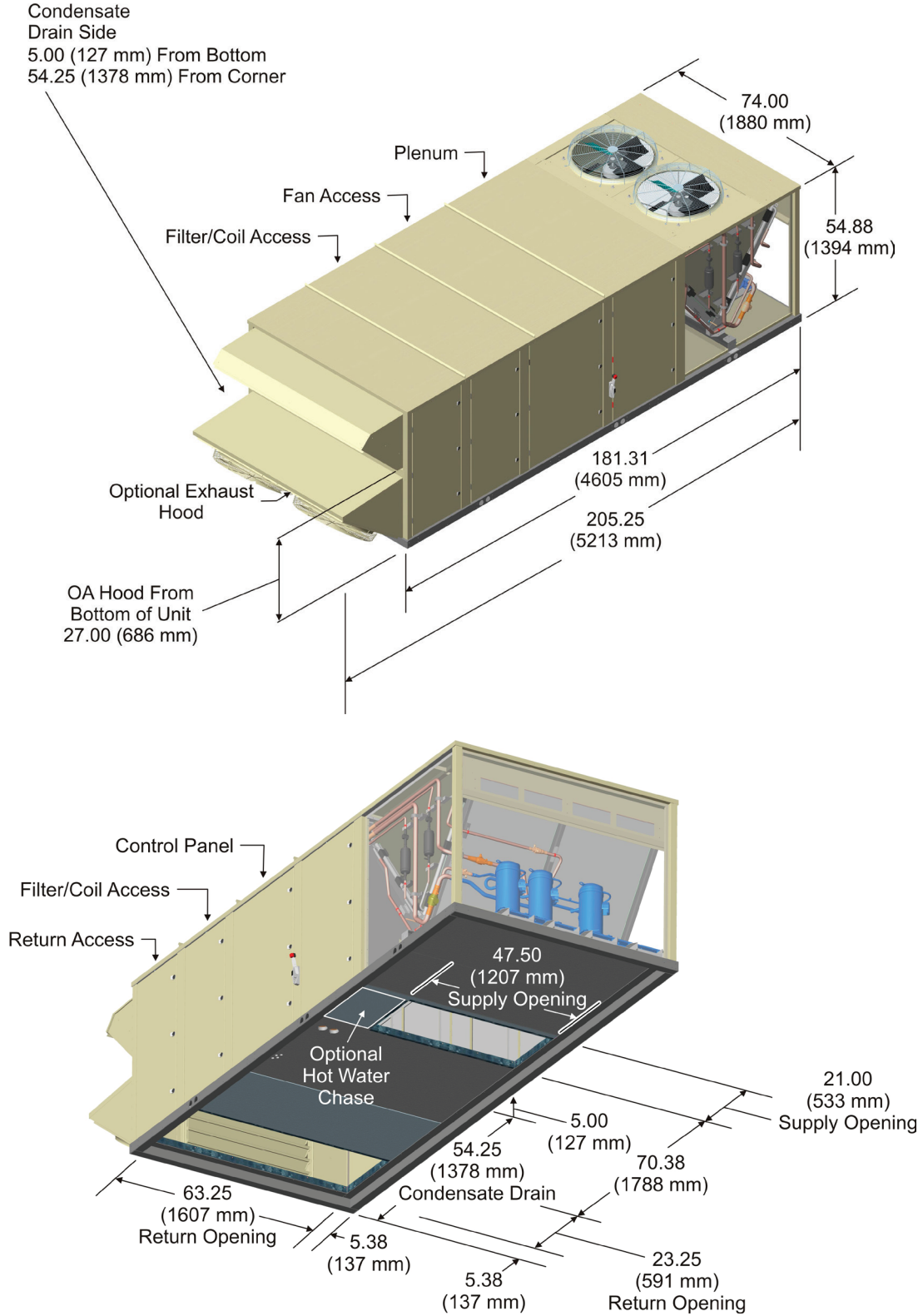
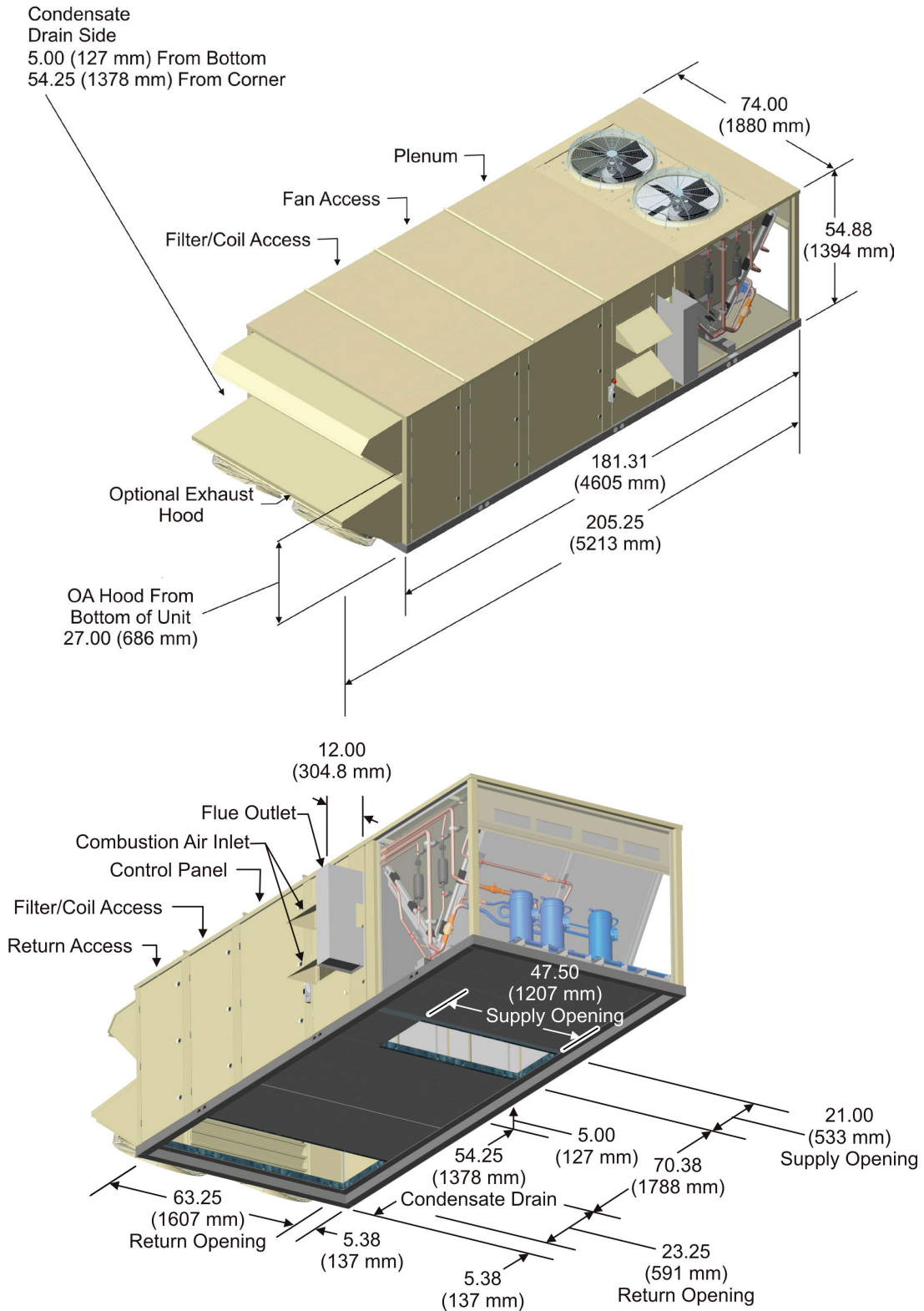
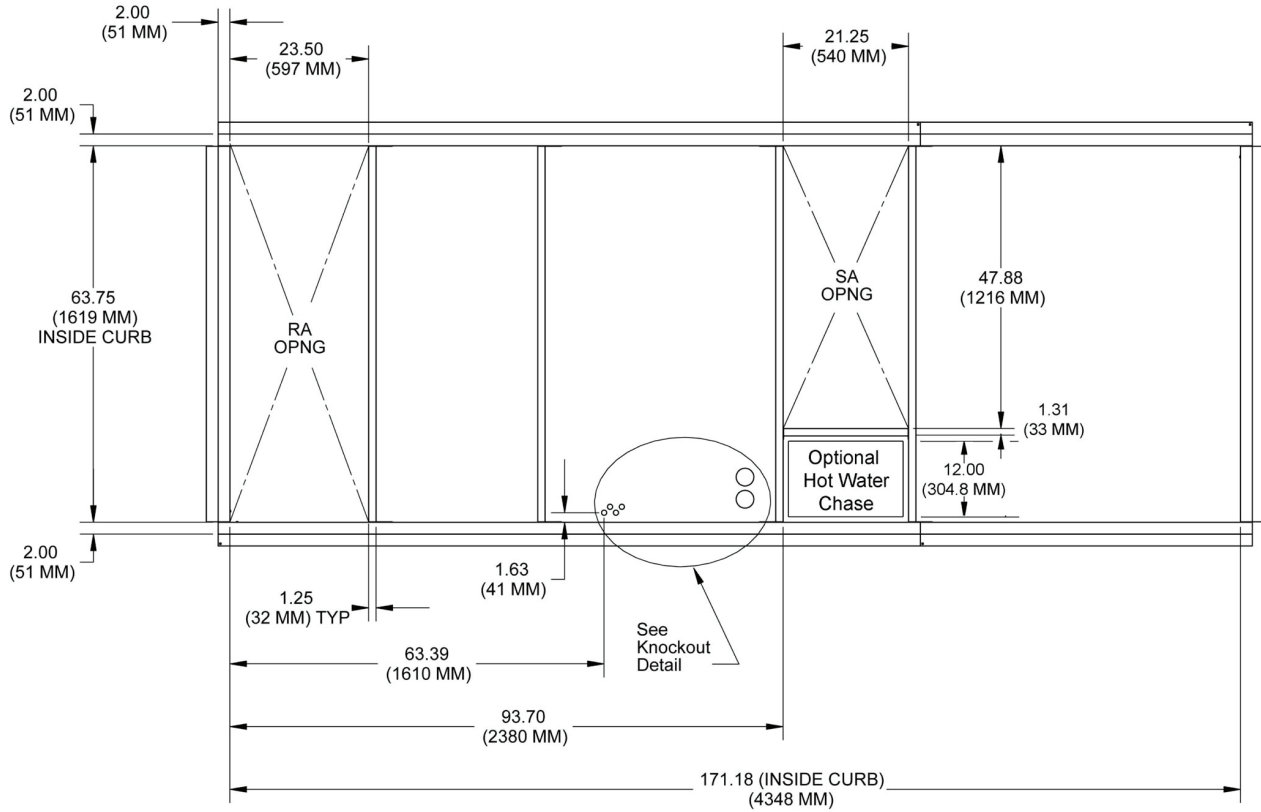

Figure 48: MPS 015-020 Cooling/Gas Heating Unit



MPS 015-020 Roof Curb Dimensions

Figure 49: MPS 015-020 Cooling/Heating Curb



PLAN VIEW

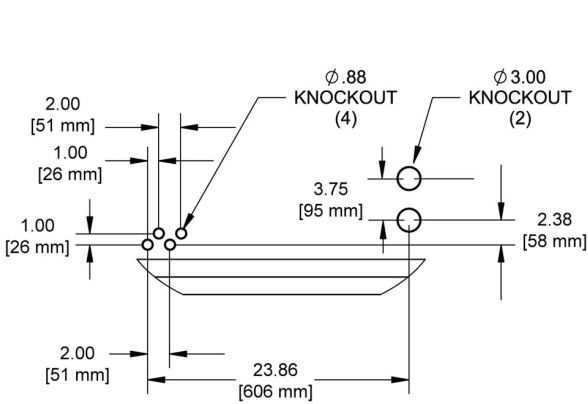

KNOCKOUT DETAIL

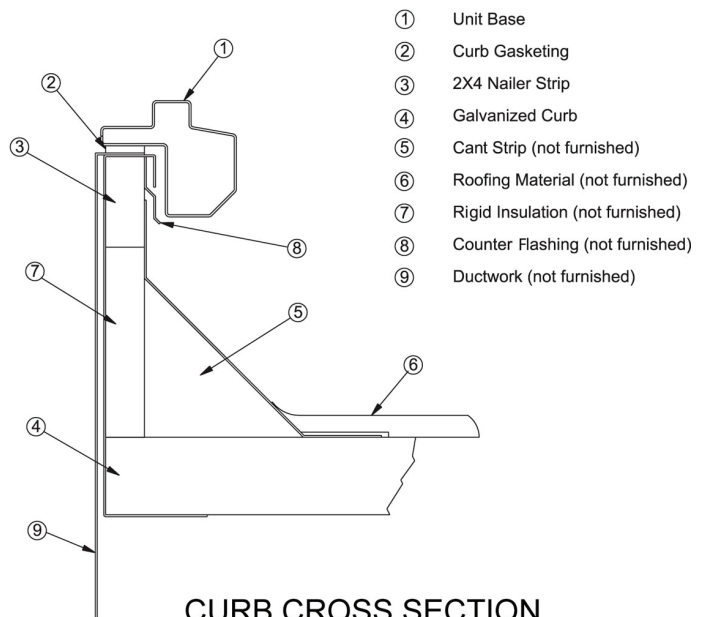

CURB CROSS SECTION

MPS 015-020 with Energy Recovery Wheel Unit Dimensions

Figure 50: MPS 015-020 Cooling Only

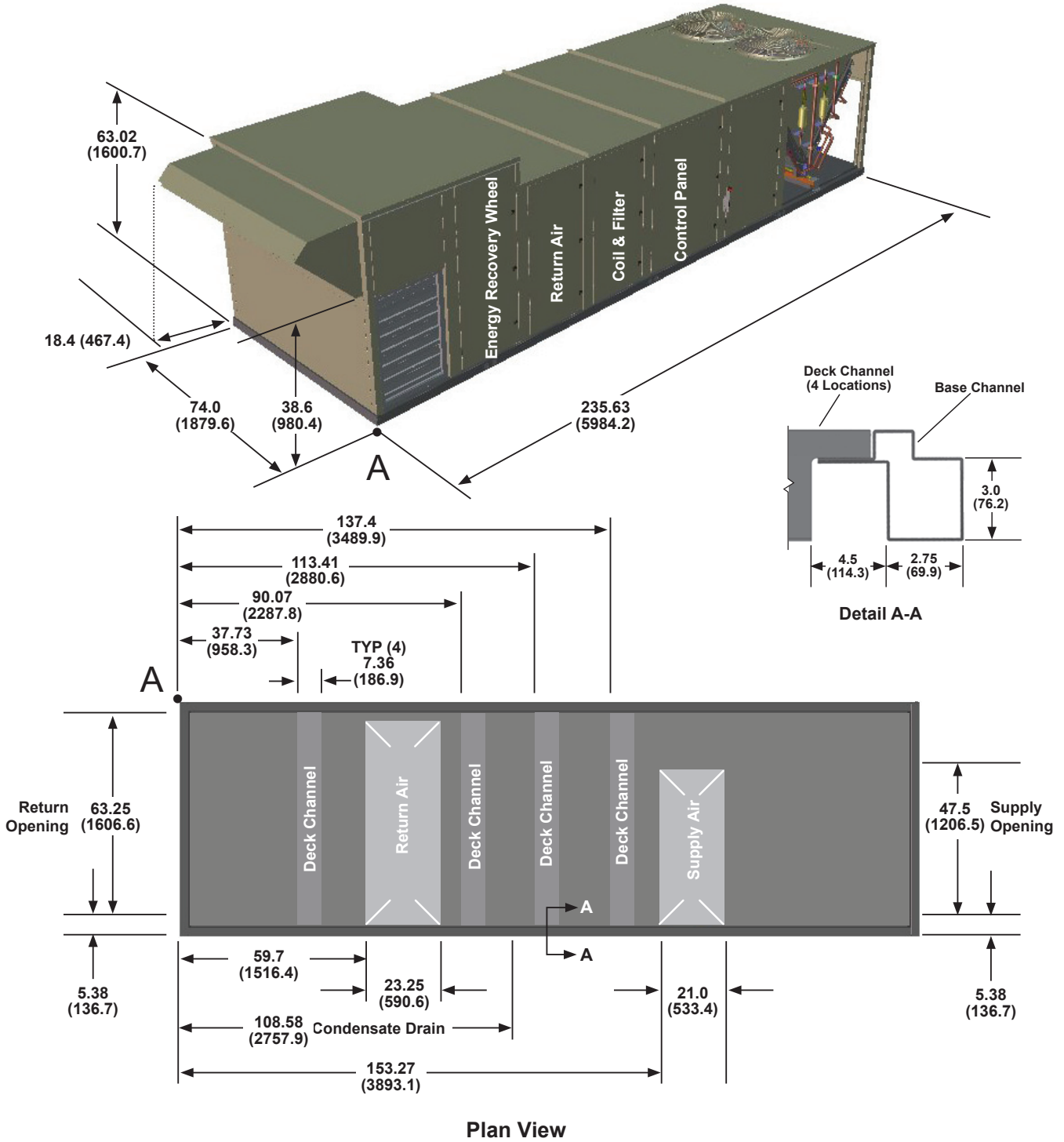
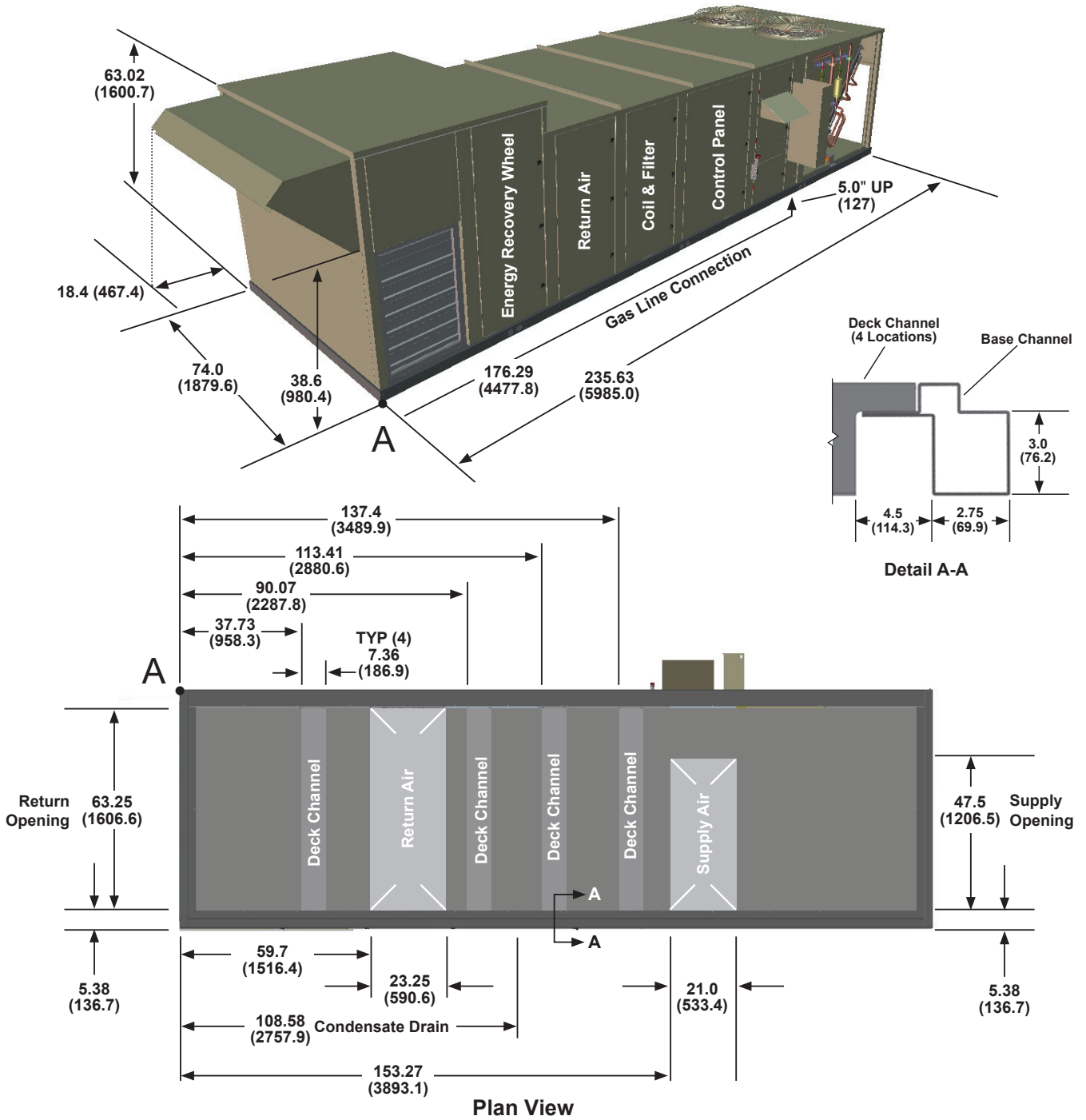
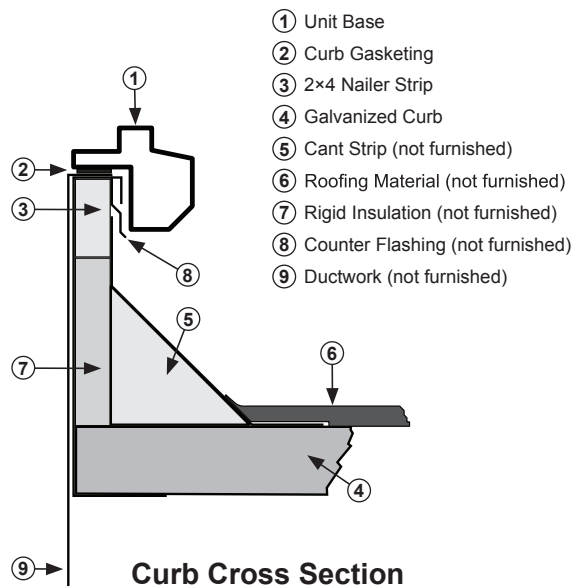
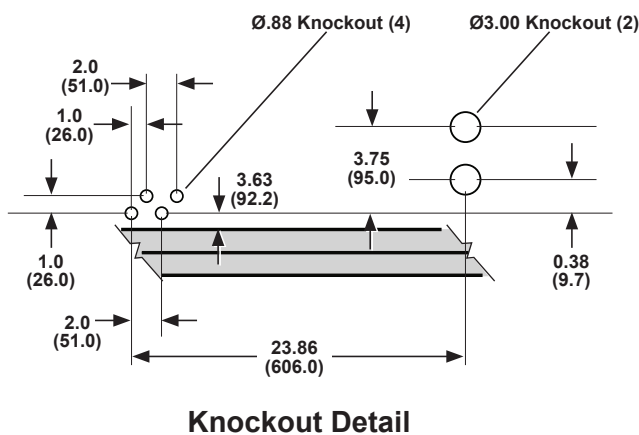
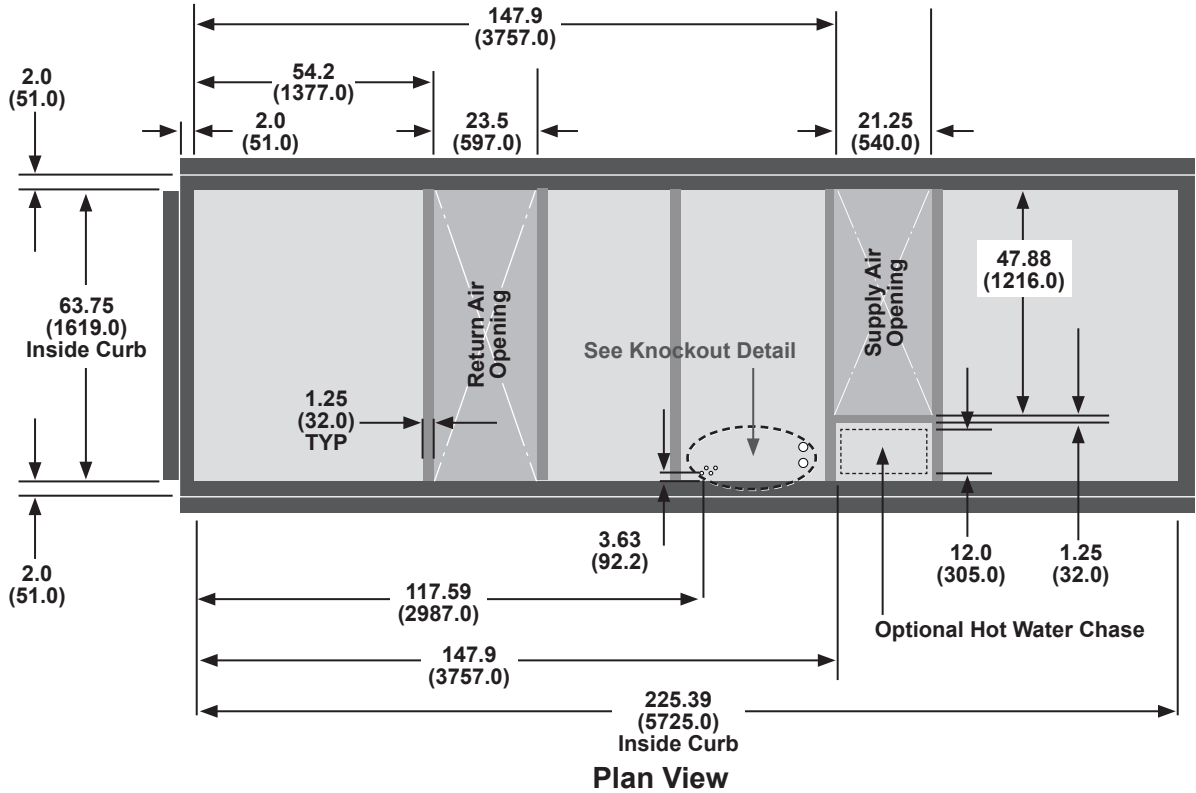

Figure 51: MPS 015–020 Gas Heat



MPS 015–020 Units with Energy Recovery Wheel Roof Curb Dimensions

Figure 52: MPS 015–020 Roof Curb



MPS 026–035 Unit Dimensions

Figure 53: MPS 026–035 Cooling/Electric Heating Unit

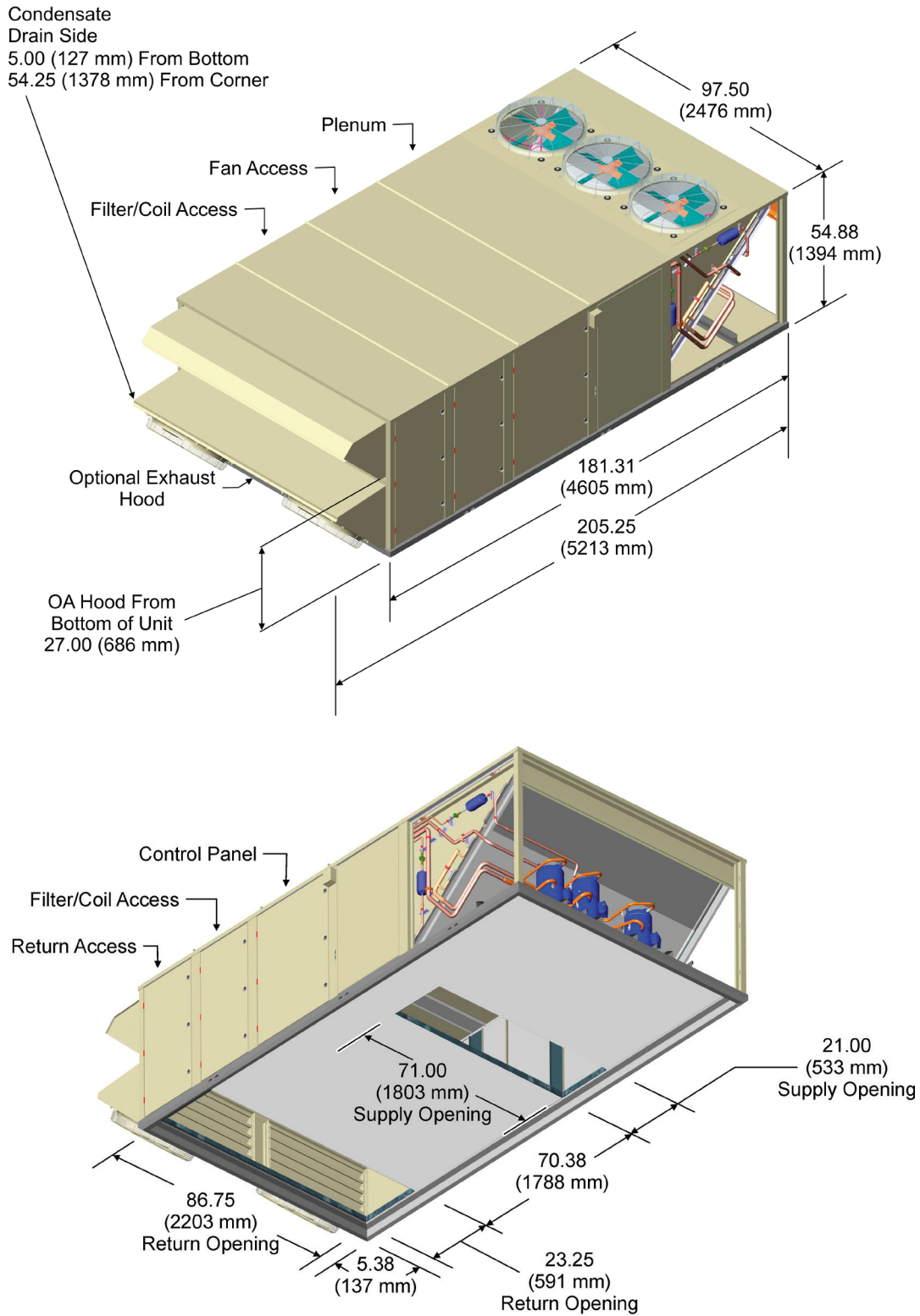

Figure 54: MPS 026–035 Cooling/Hot Water Heating Unit

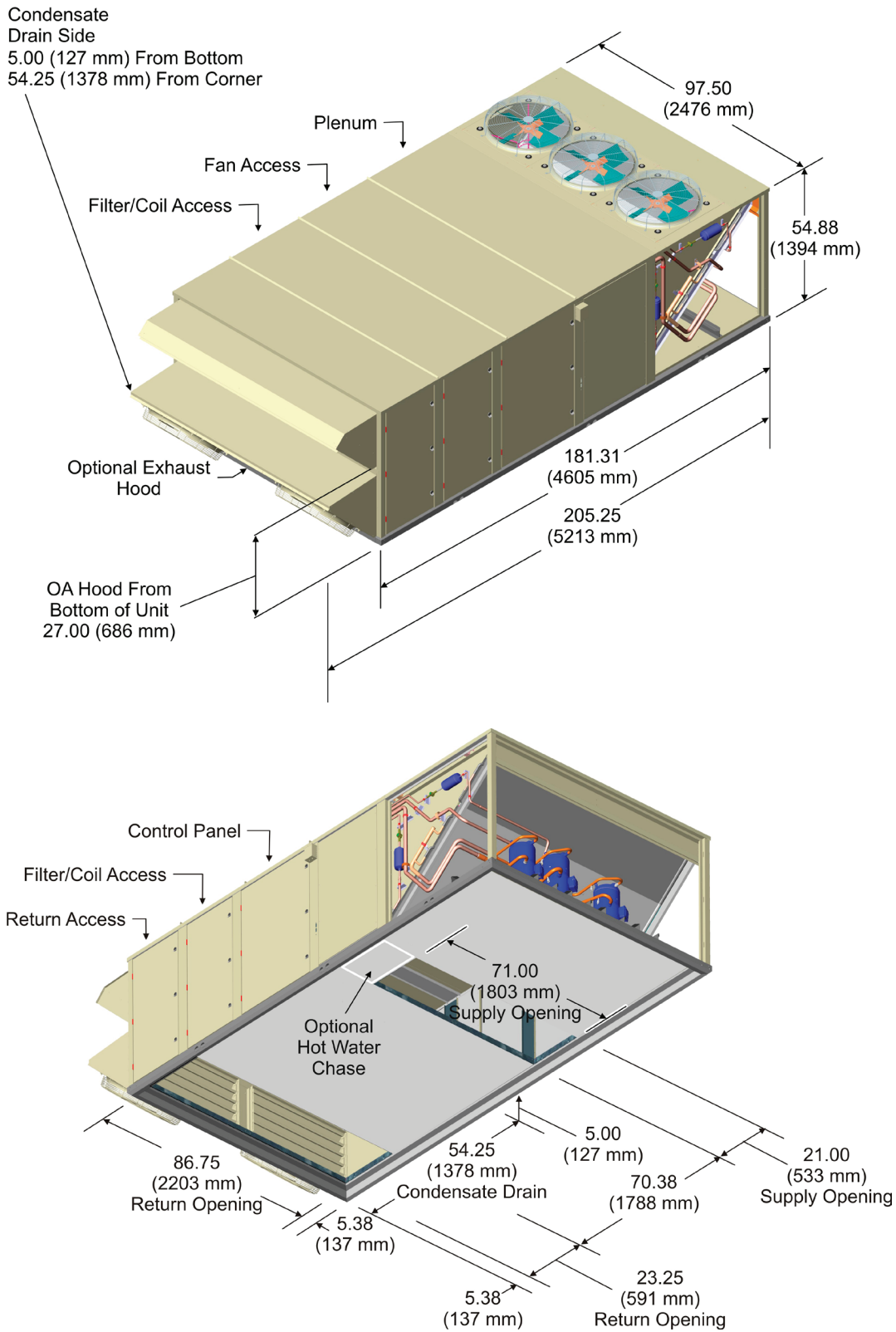
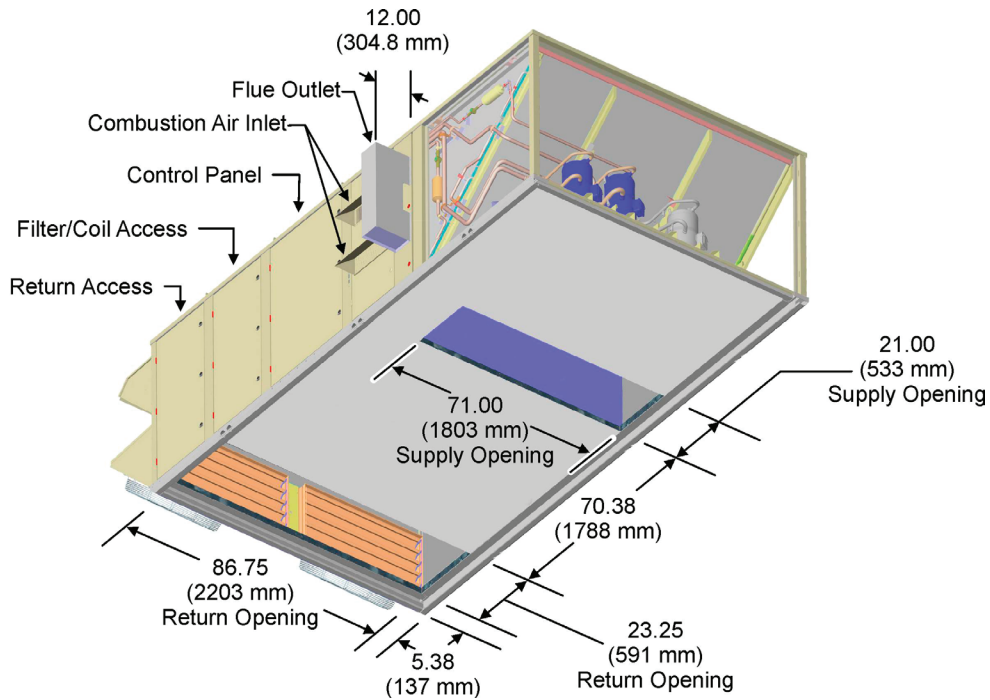
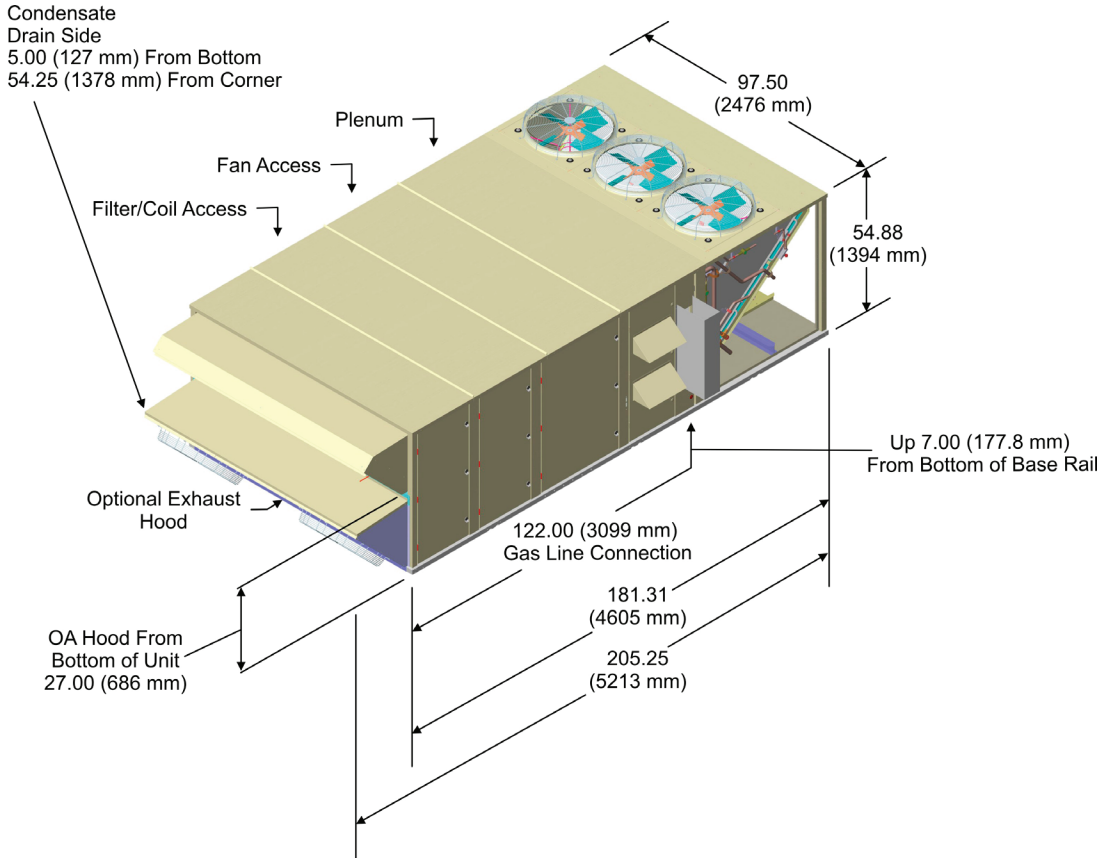
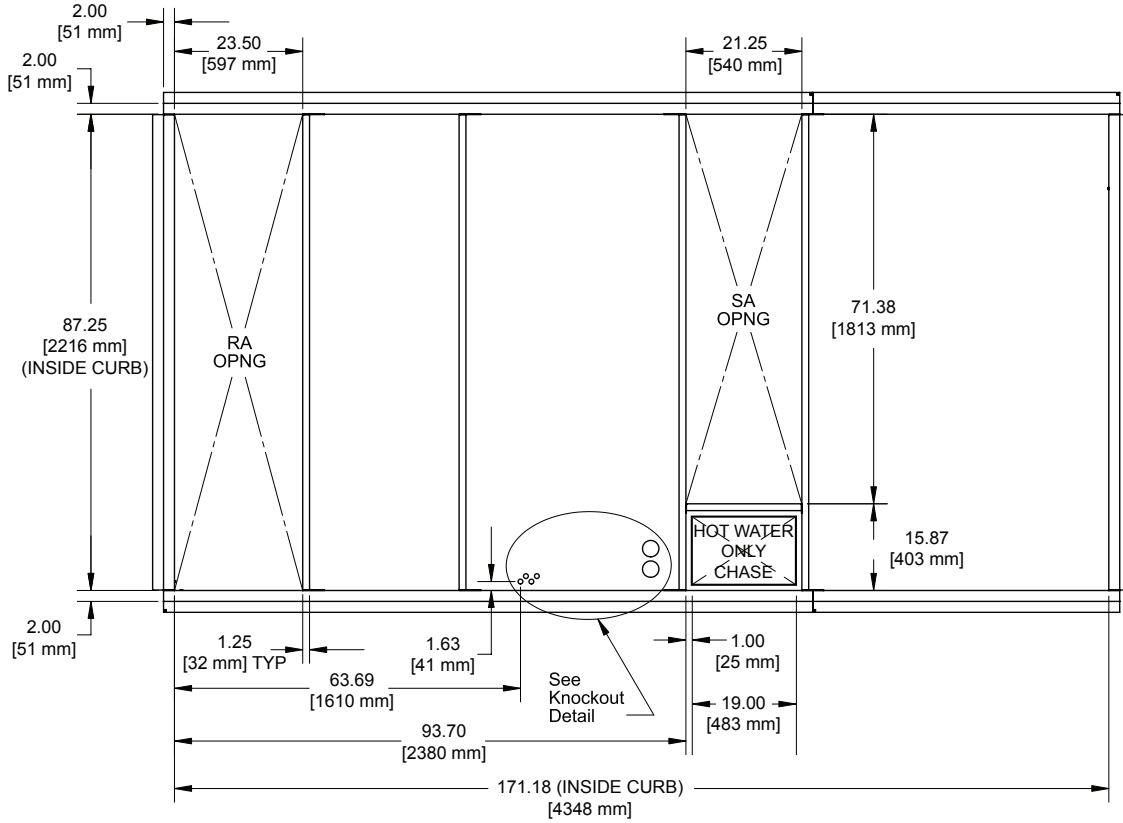

Figure 55: MPS 026–035 Cooling/Gas Heating Unit



MPS 026-035 Roof Curb Dimensions

Figure 56: MPS 026-035 Cooling/Heating Curb



PLAN VIEW

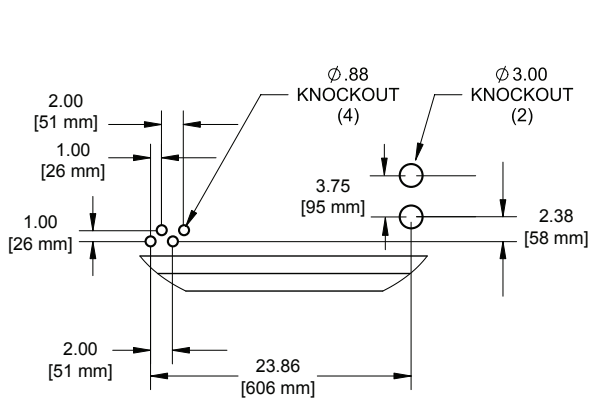

KNOCKOUT DETAIL

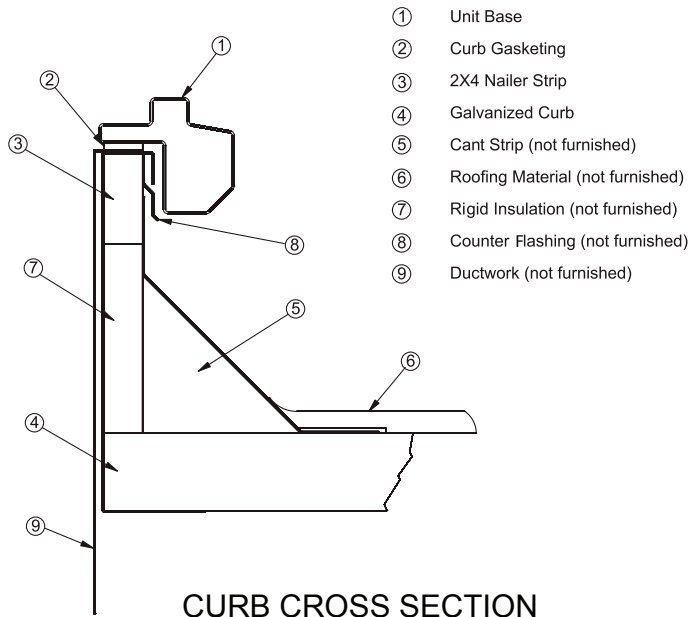

CURB CROSS SECTION

MPS 026–035 with Energy Recovery Wheel Unit Dimensions

Figure 57: MPS 026–035 Cooling Only, Standard Diameter Energy Recovery Wheel

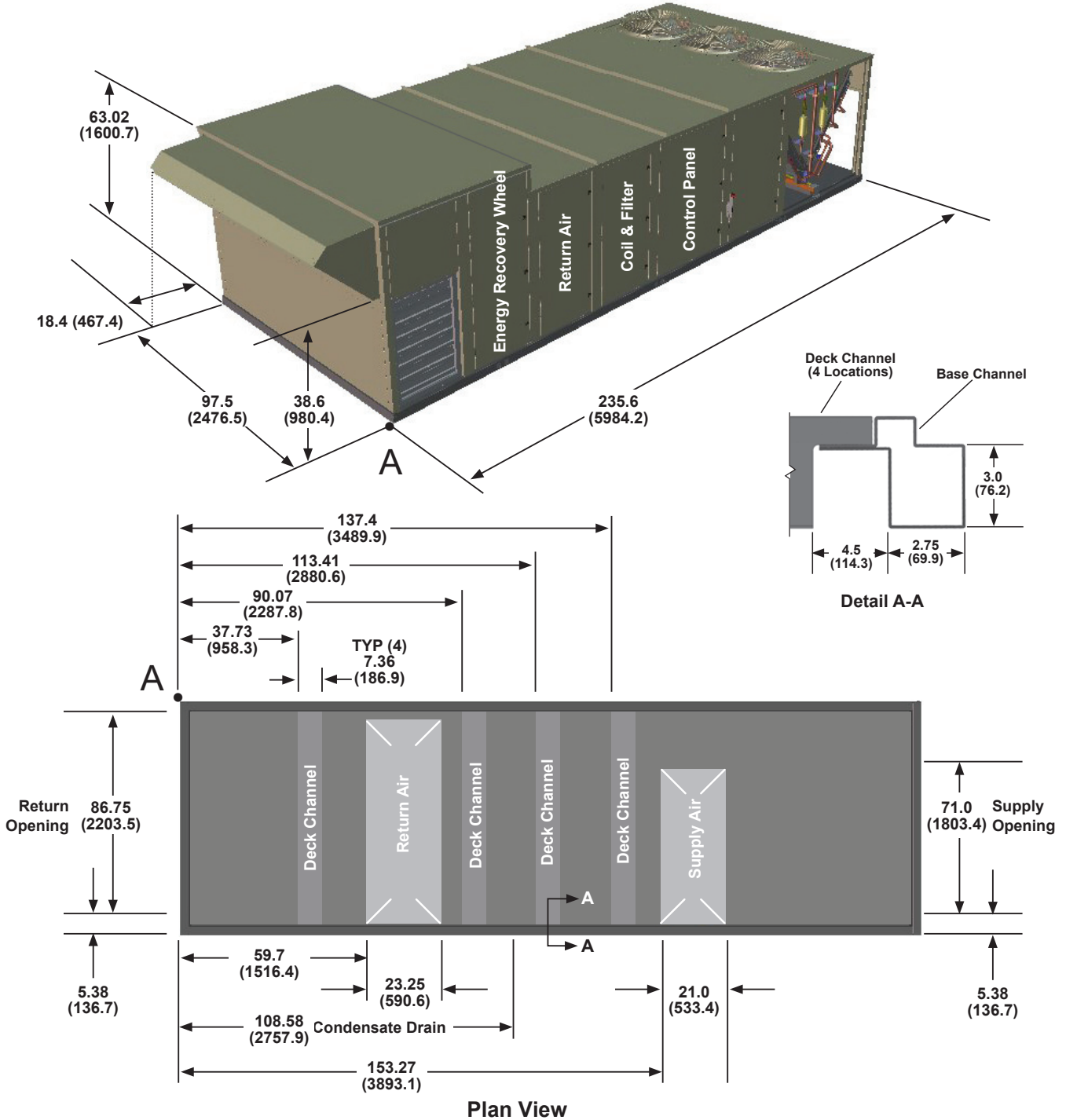

Figure 58: MPS 026–035 Cooling Only, Large Diameter Energy Recovery Wheel

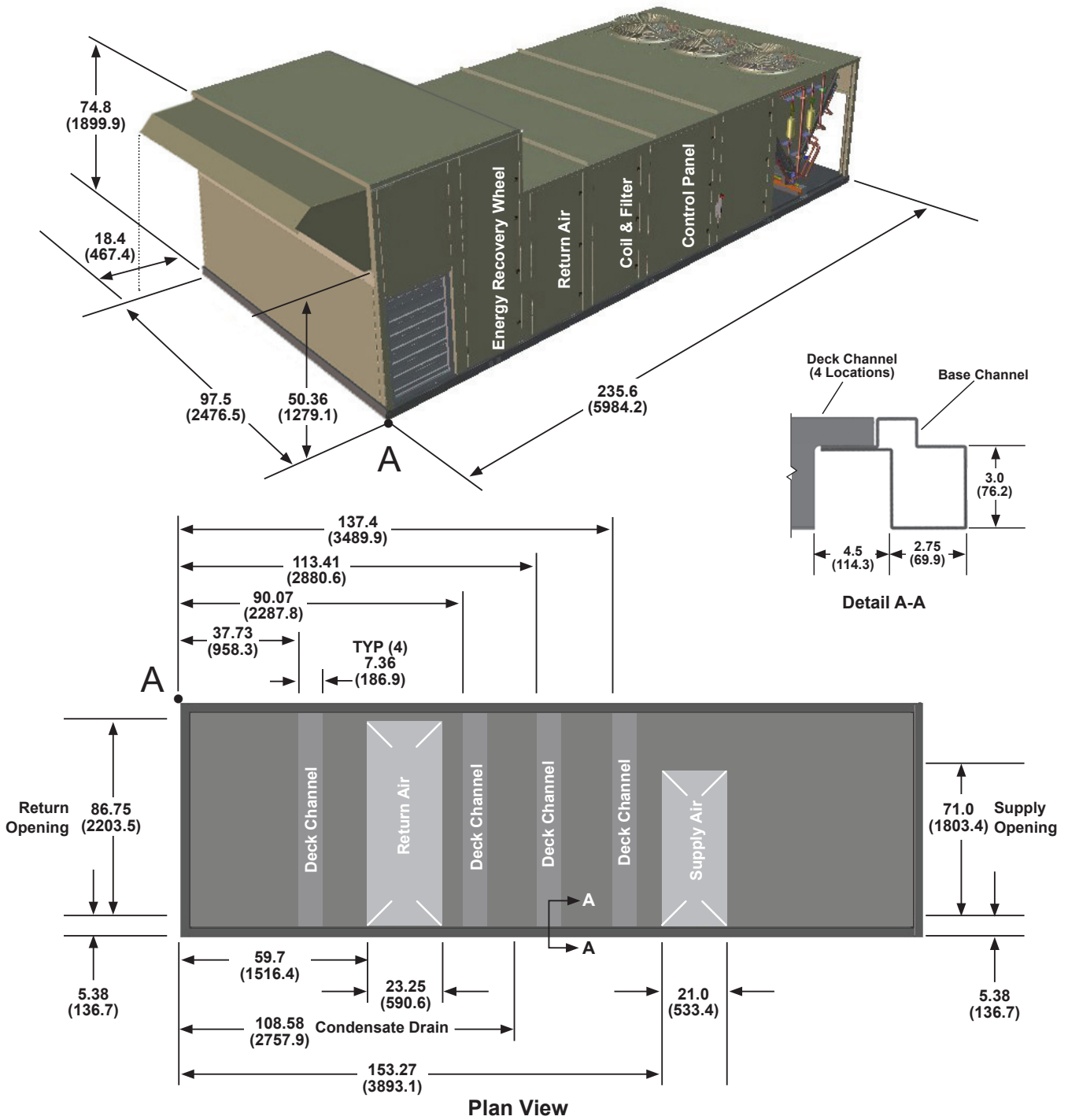

Figure 59: MPS 026–035 Gas Heat, Standard Diameter Energy Recovery Wheel

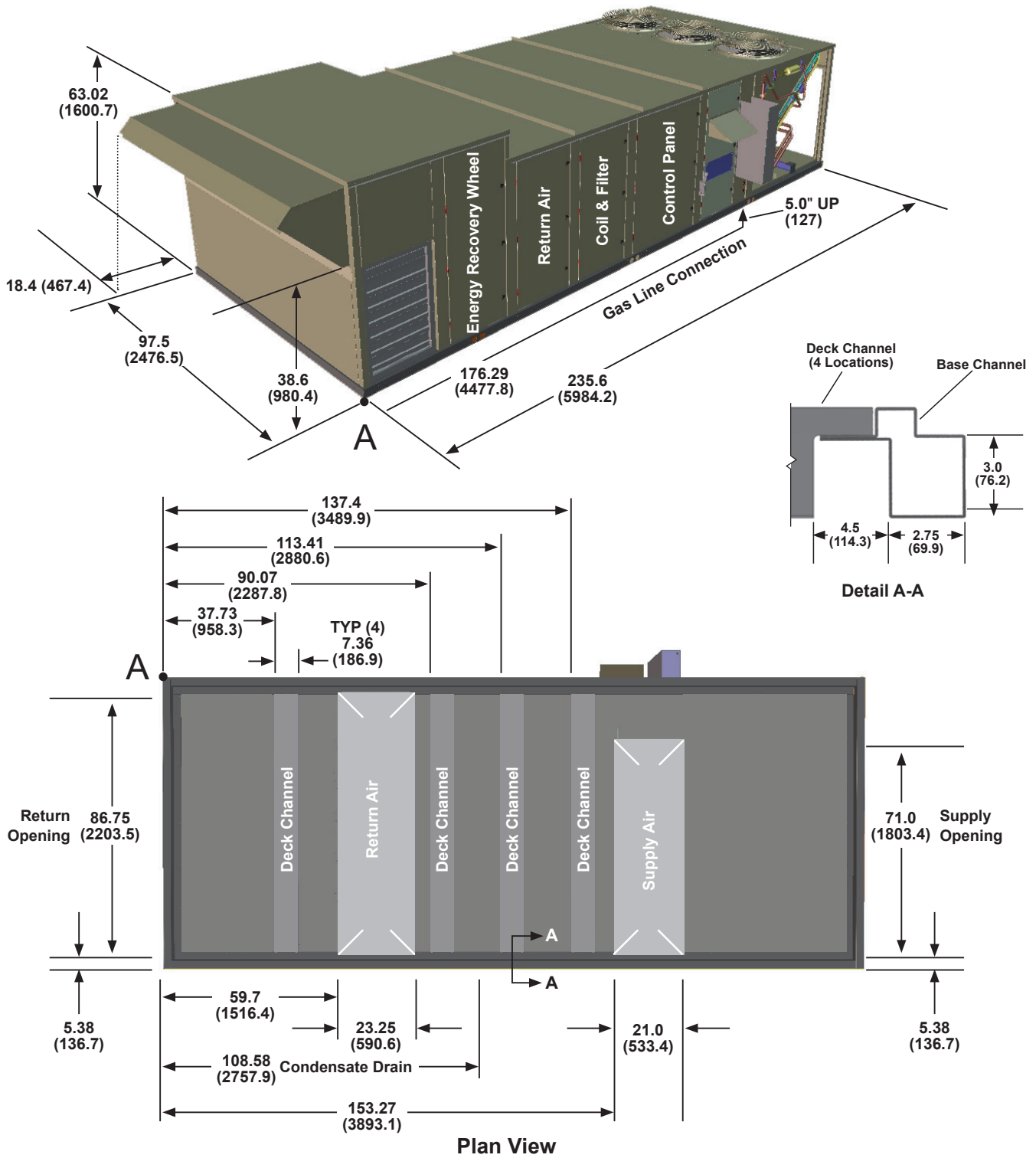
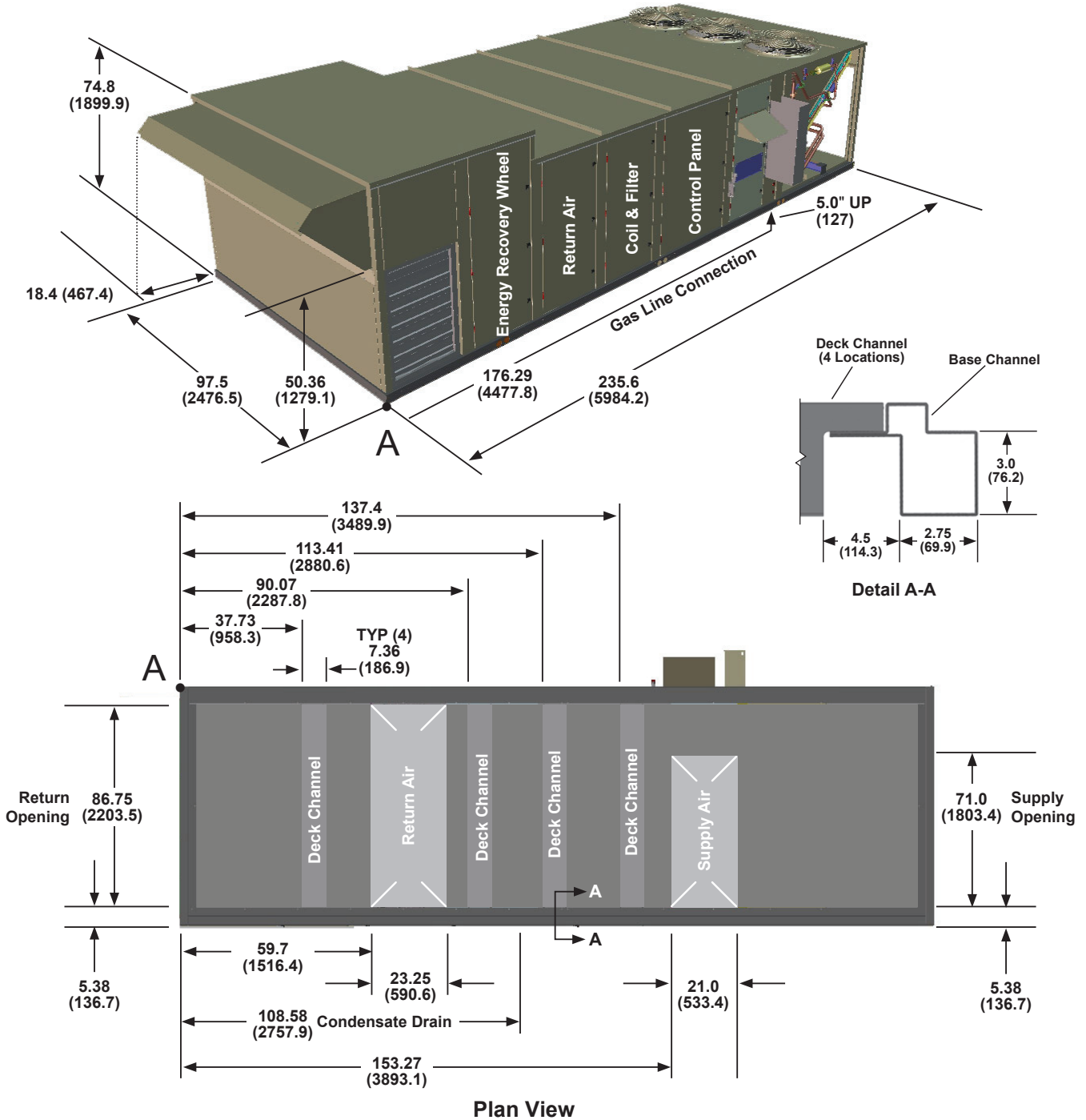
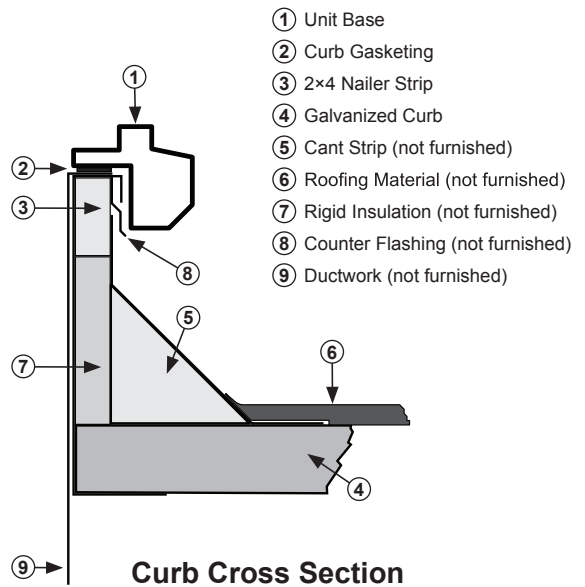
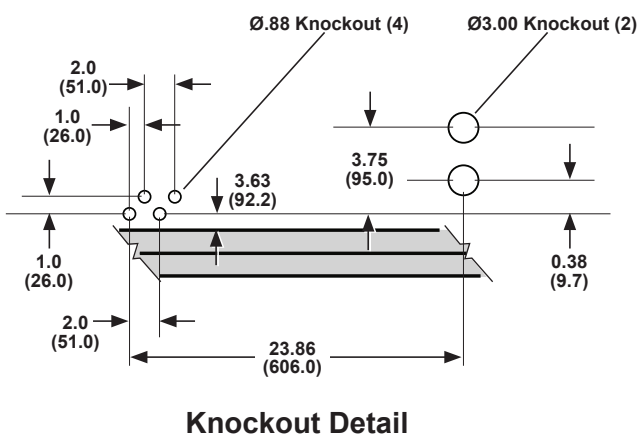
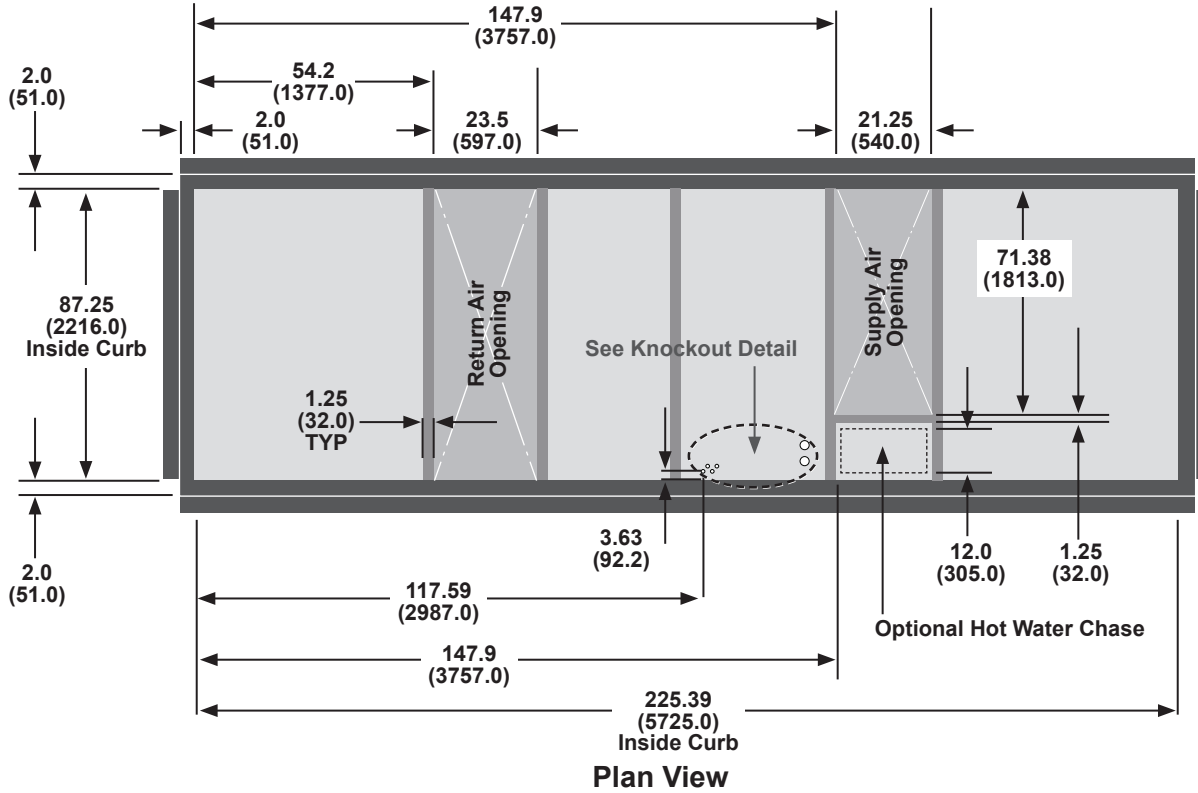

Figure 60: MPS 026–035 Gas Heat, Large Diameter Energy Recovery Wheel



MPS 026–035 Units with Energy Recovery Wheel Roof Curb Dimensions

Figure 61: MPS 026–035 Roof Curb



MPS 040-050 Unit Dimensions

Figure 62: MPS 040-050 Cooling/Electric Heating Unit

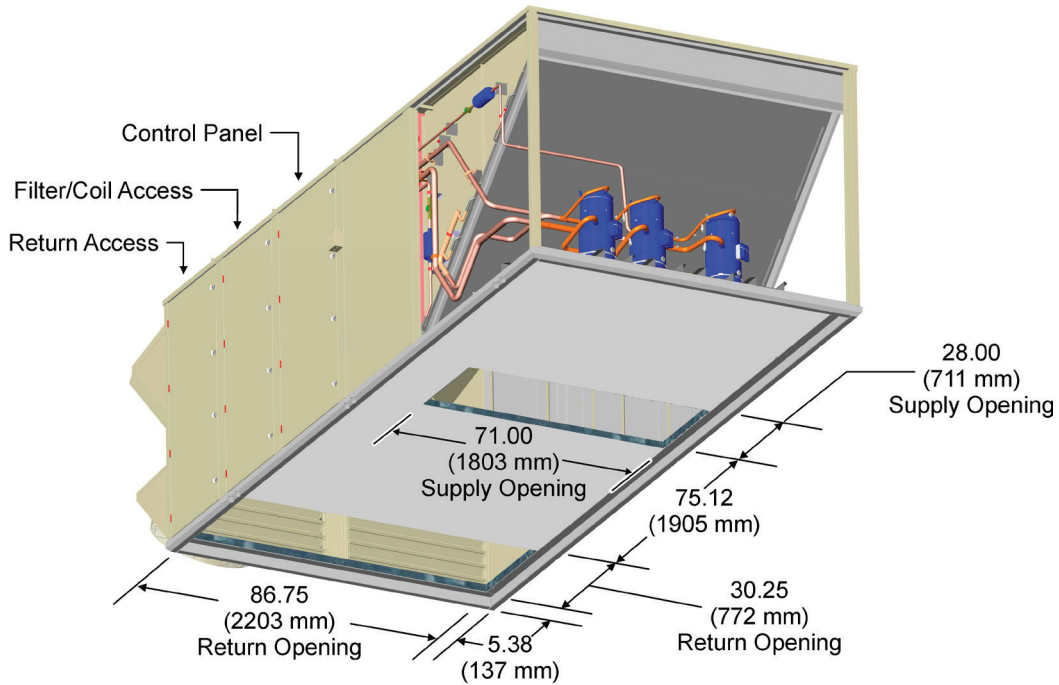
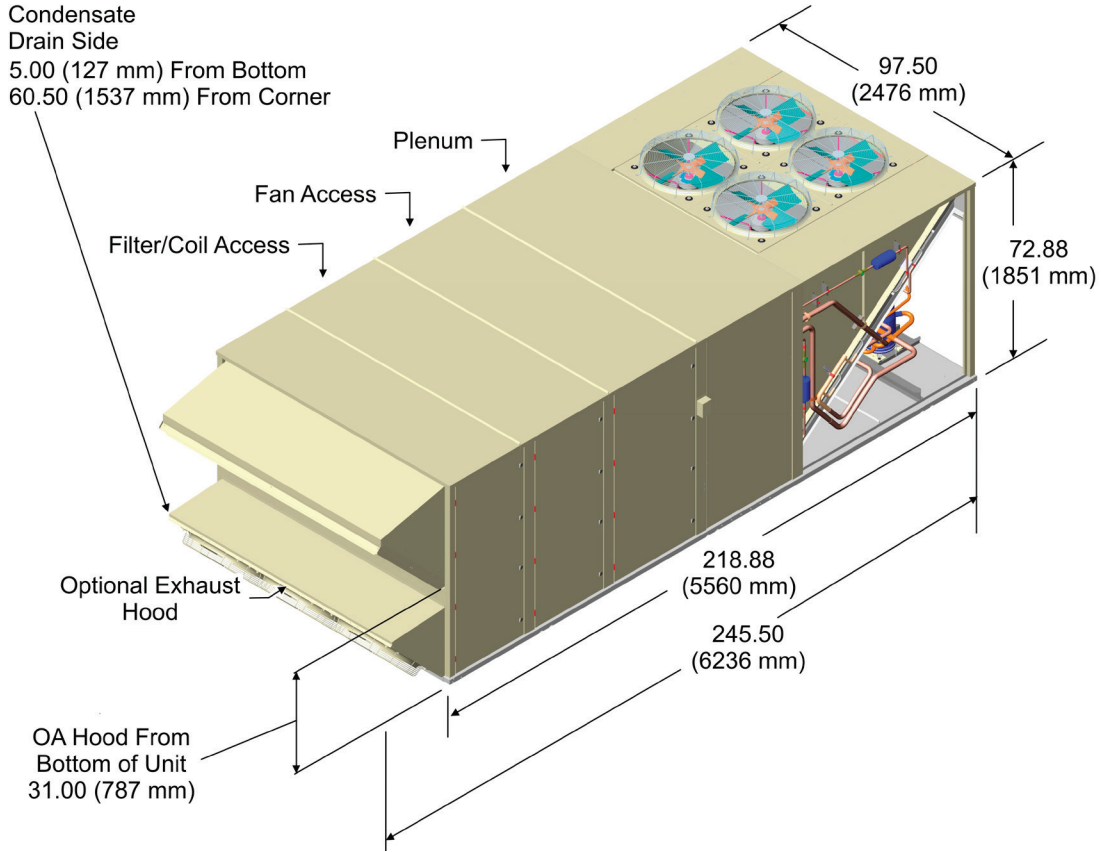

Figure 63: MPS 040–050 Cooling/Hot Water Heating Unit

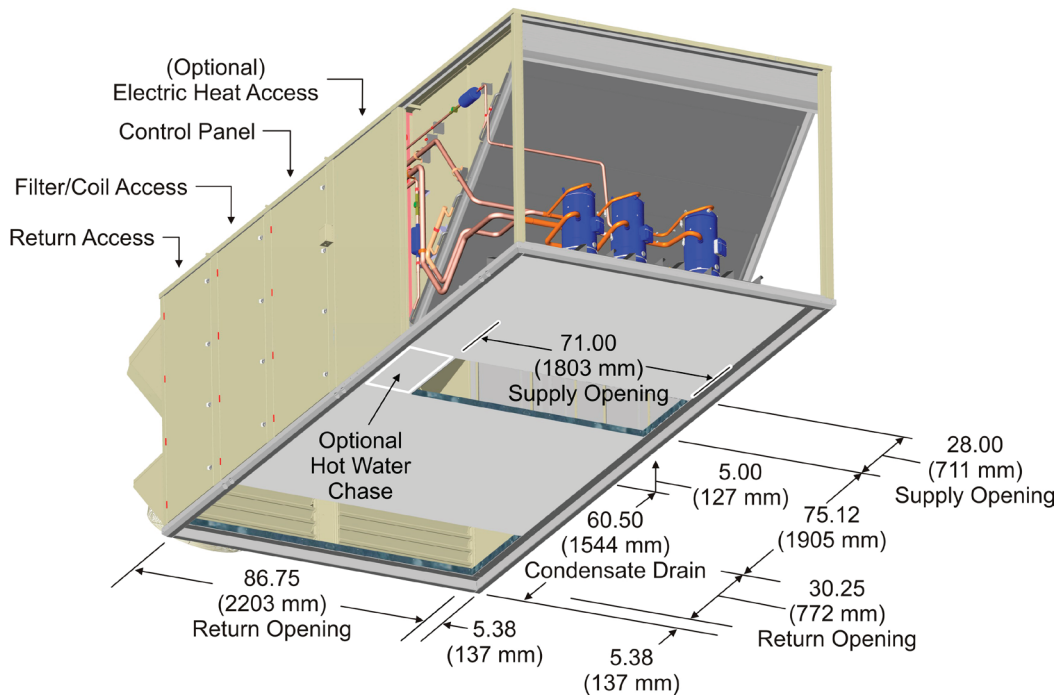
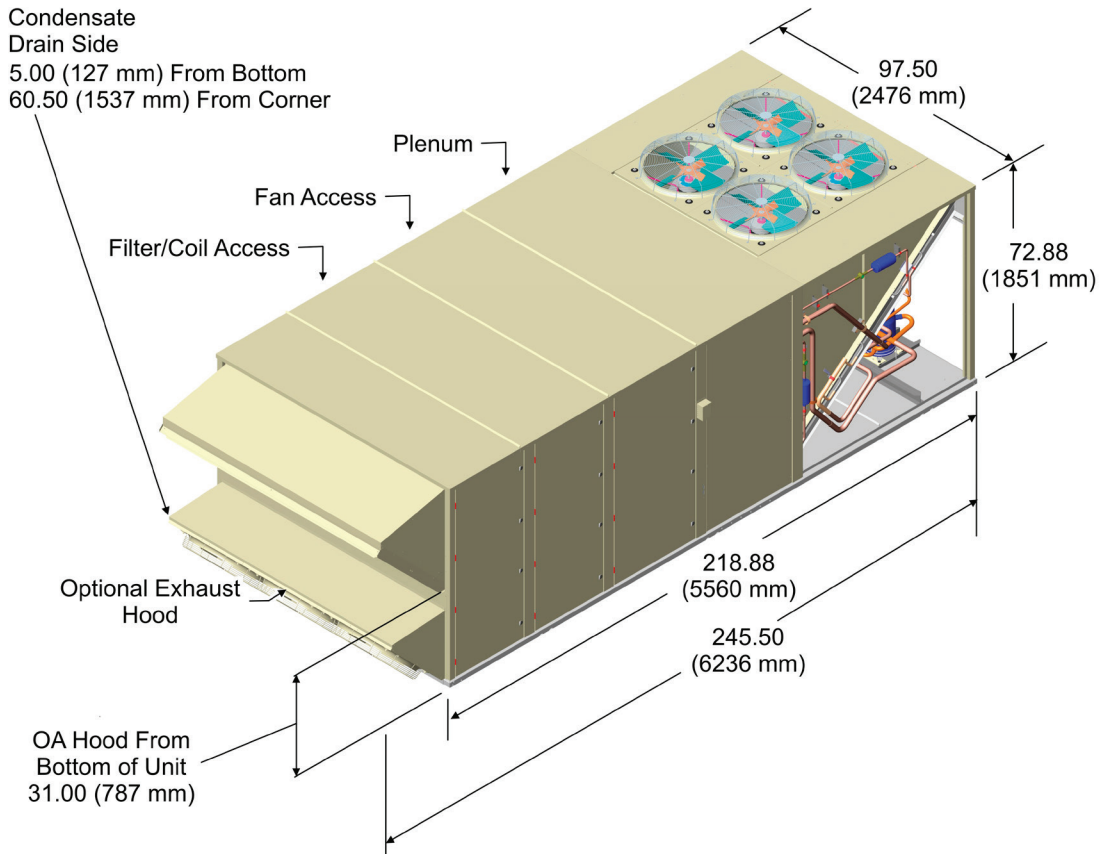
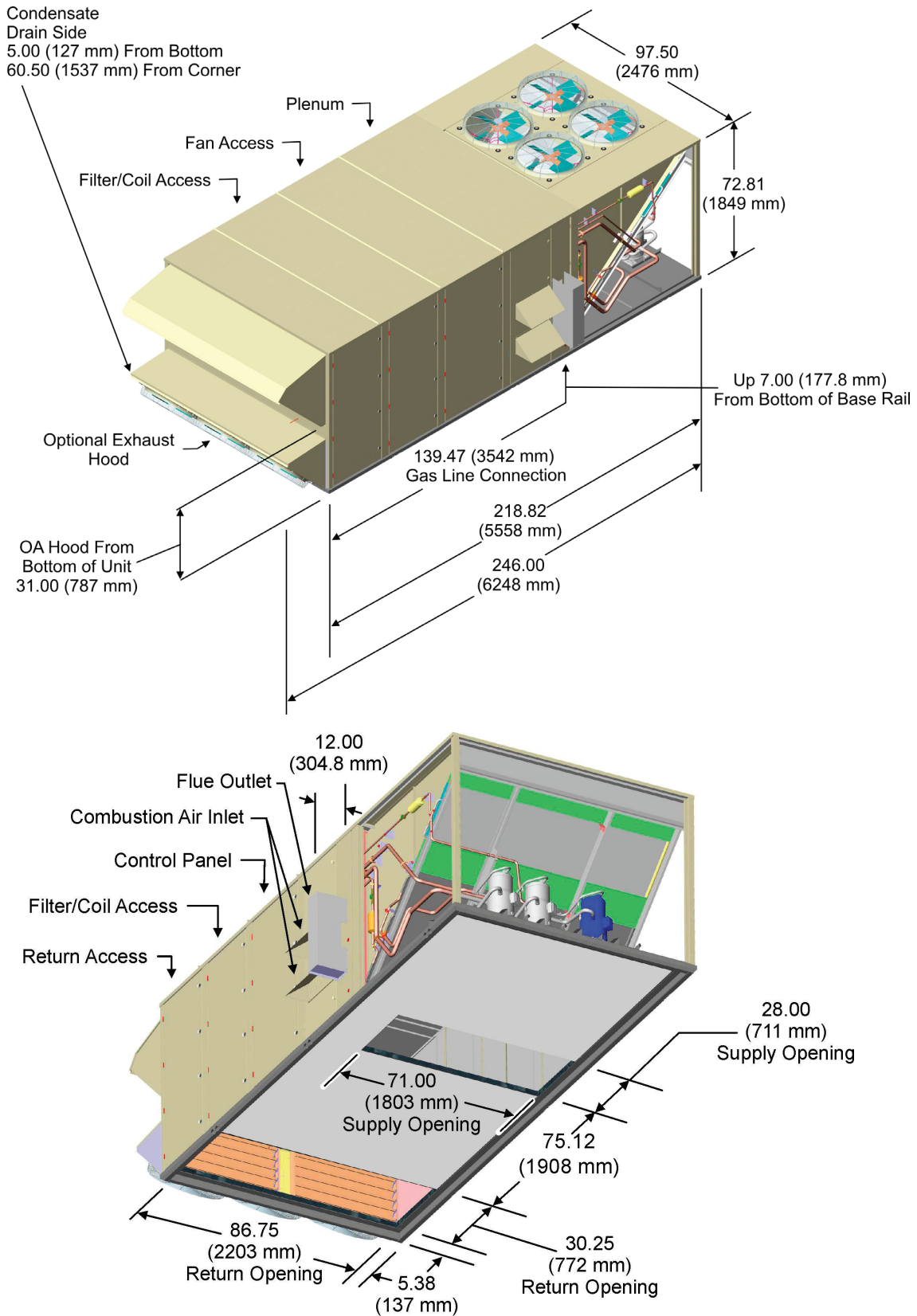
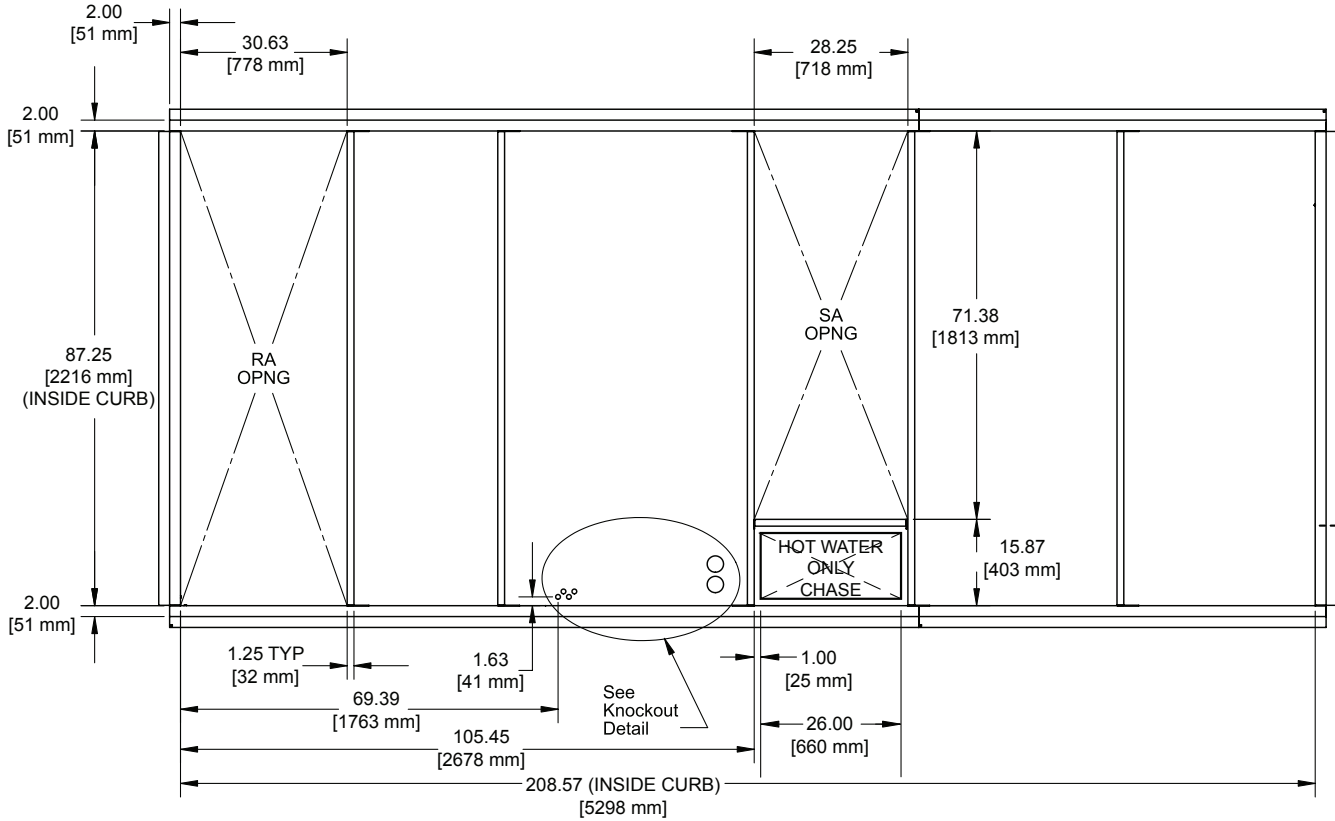

Figure 64: MPS 040-050 Cooling/Gas Heating Unit



040-050 Roof Curb Dimensions

Figure 65: MPS 040-050 Cooling/Heating Curb



PLAN VIEW

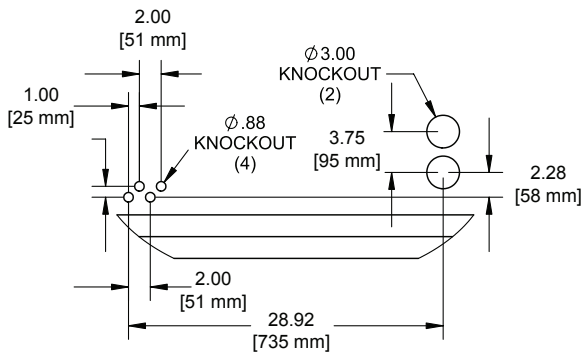

KNOCKOUT DETAIL

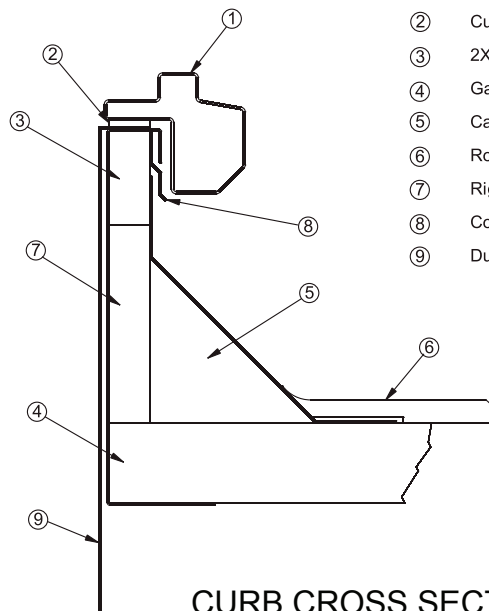

- ① Unit Base
- ② Curb Gasketing
- ③ 2X4 Nailer Strip
- ④ Galvanized Curb
- ⑤ Cant Strip (not furnished)
- ⑥ Roofing Material (not furnished)
- ⑦ Rigid Insulation (not furnished)
- ⑧ Counter Flashing (not furnished)
- ⑨ Ductwork (not furnished)

CURB CROSS SECTION

MPS 040–050 Units with Energy Recovery Wheel Dimensions

Figure 66: MPS 040–050 Cooling Only

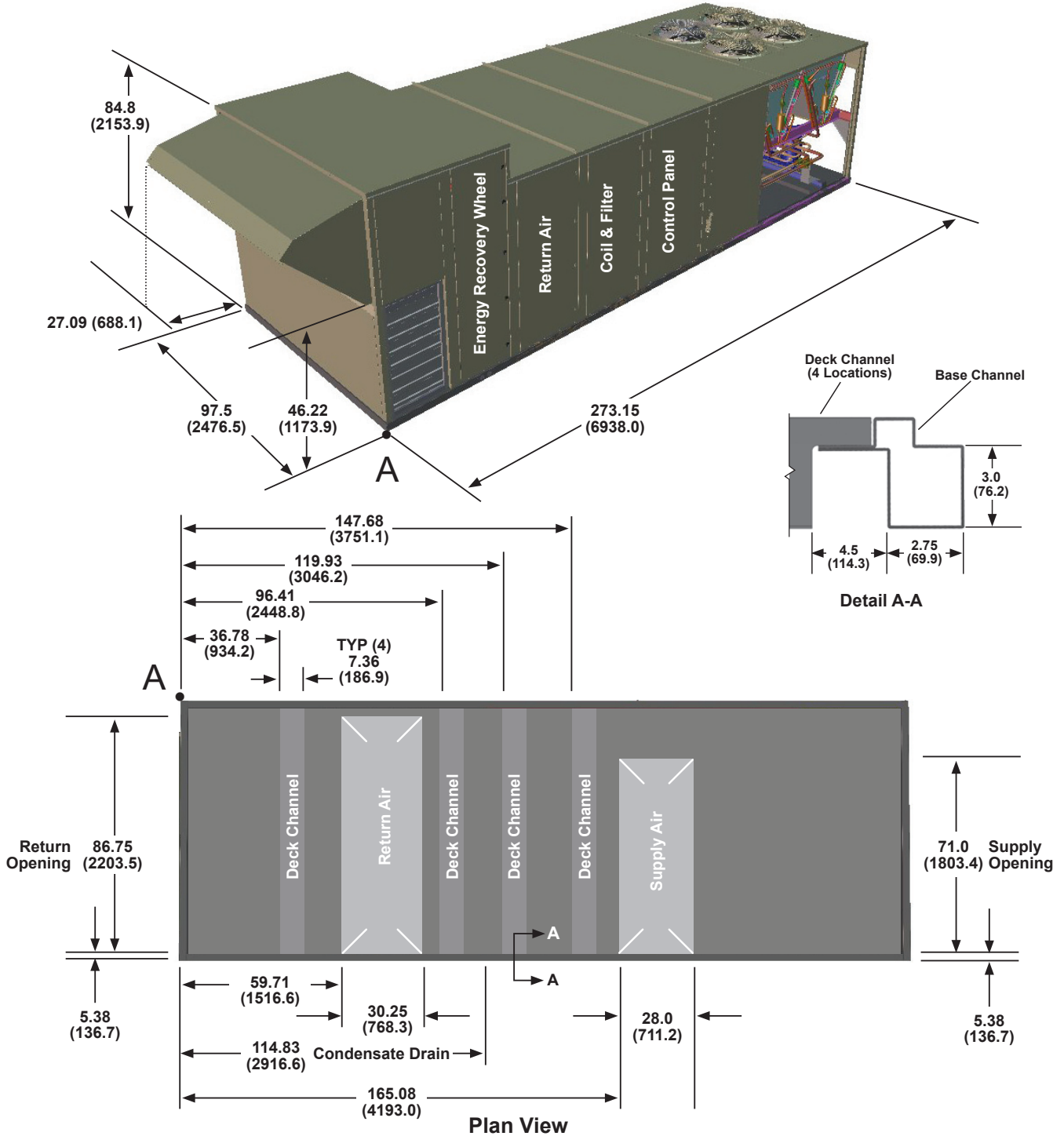
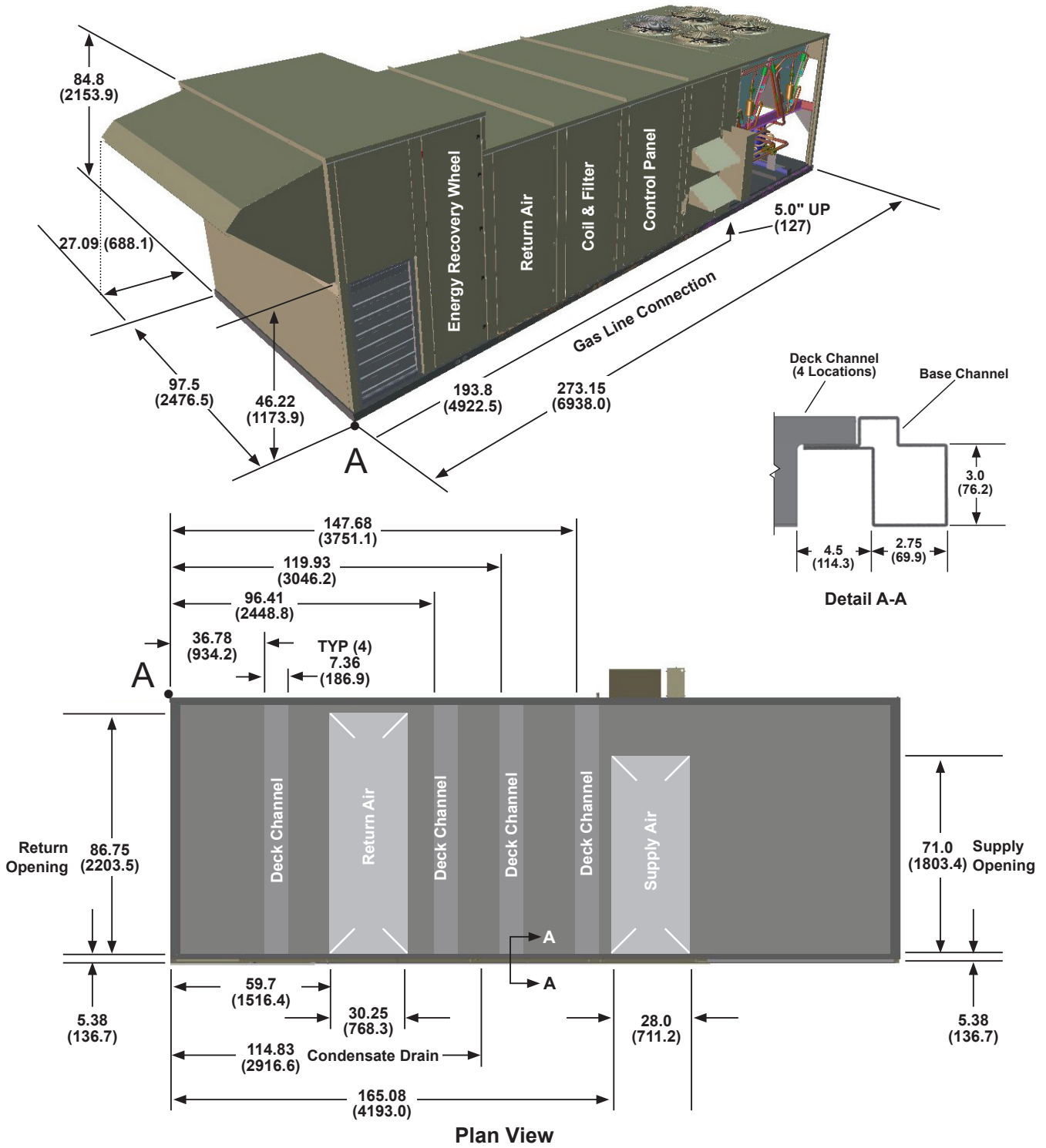
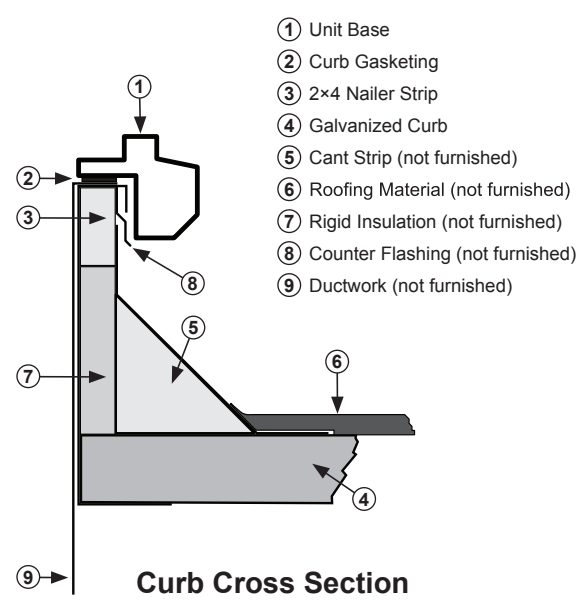
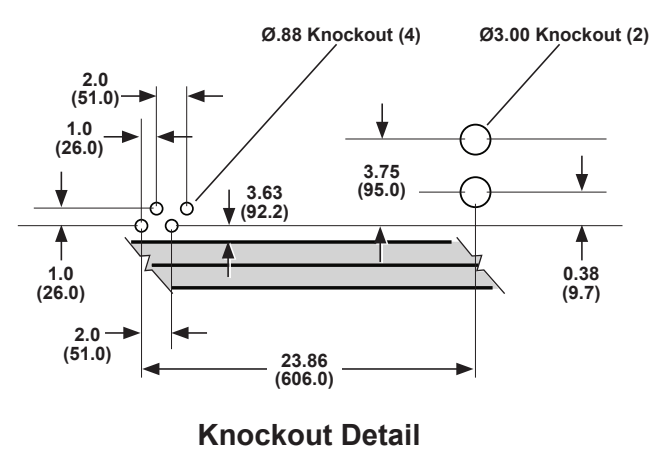
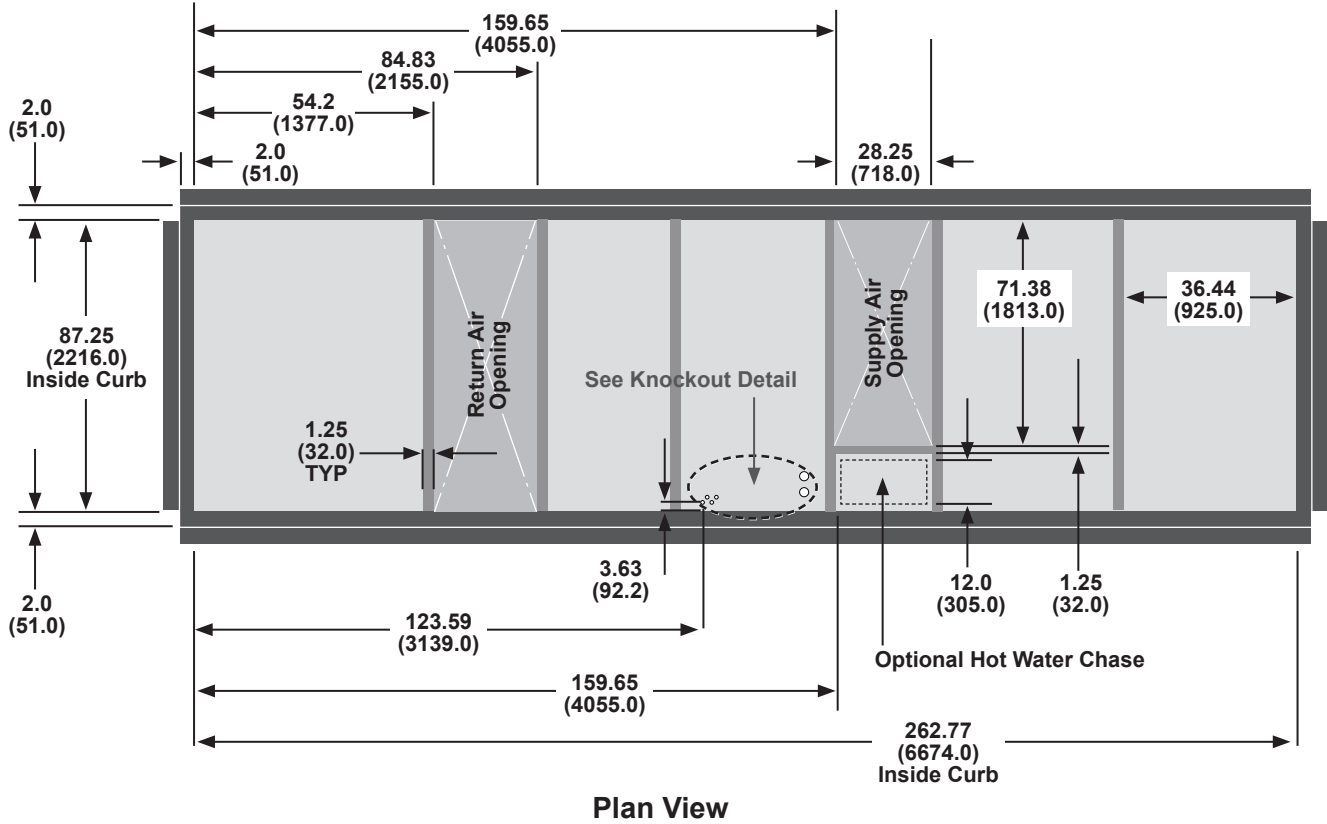

Figure 67: MPS 040–050 Gas Heat



MPS 040-050 Units with Energy Recovery Wheel Roof Curb Dimensions

Figure 68: MPS 040-050 Roof Curb



MPS 061 Unit and Curb Dimensions

Figure 69: Longest MPS 061 Cooling/Gas or Electric Heating Unit

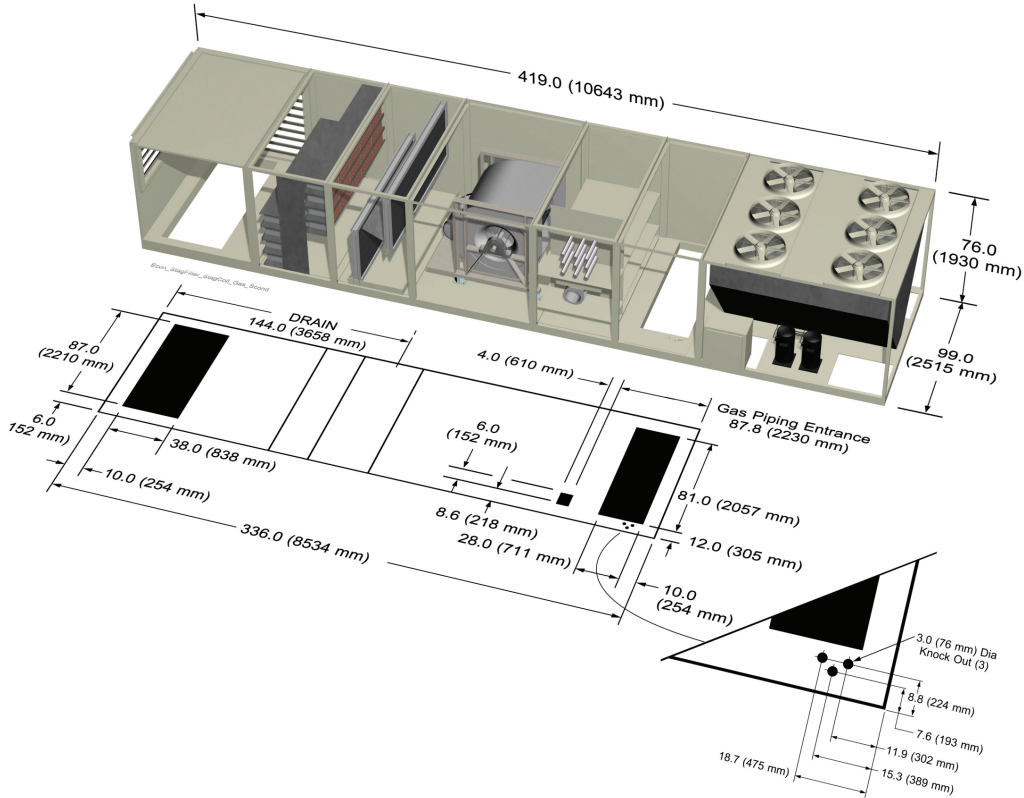
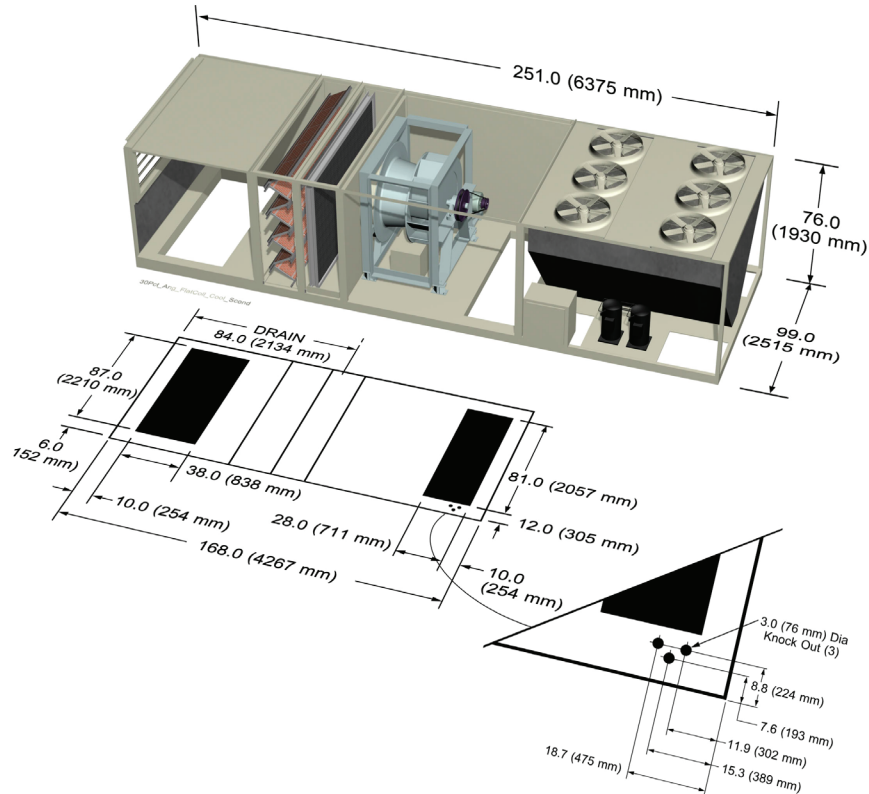

Figure 70: Shortest MPS 061 Cooling Only Unit



MPS 070–075 Unit and Curb Dimensions

Figure 71: Longest MPS 070–075 Cooling/Gas or Electric Heating Unit

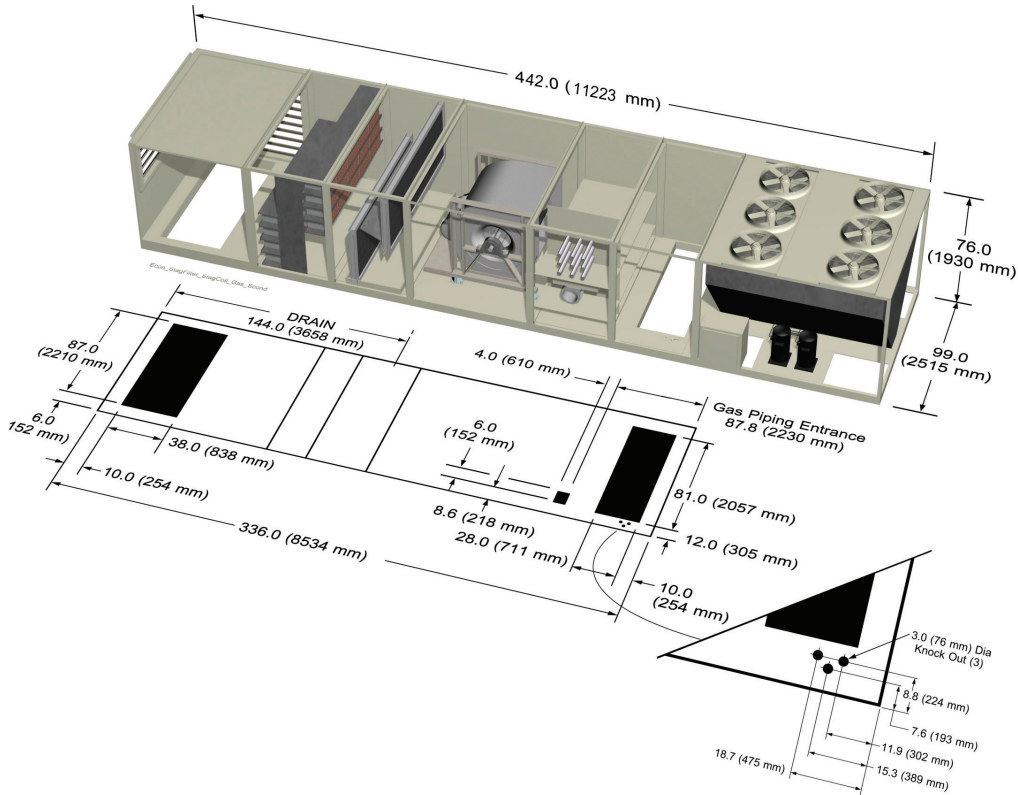
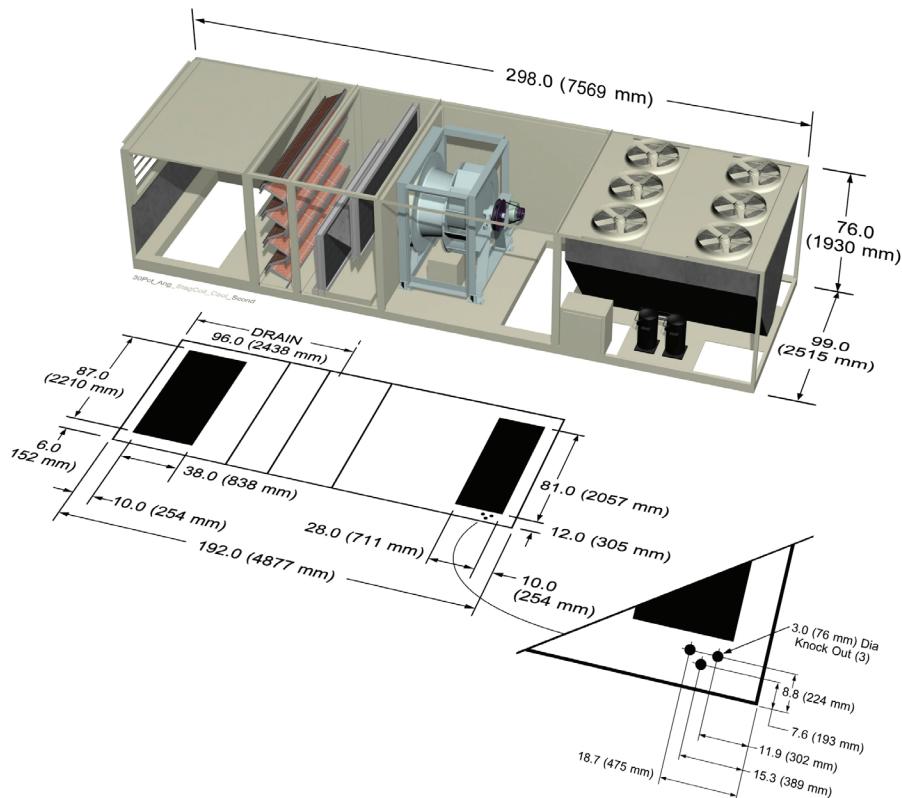

Figure 72: Shortest MPS 070–075 Cooling Only Unit



MPS 061-075 Additional Curb Dimensions

Figure 73: Curb Cross Section

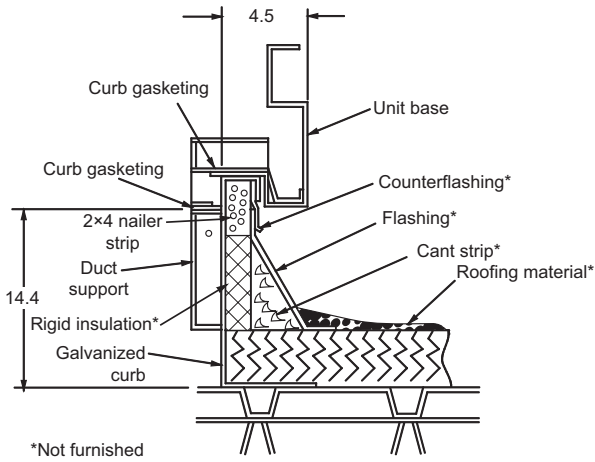

Figure 74: Curb Cross Section

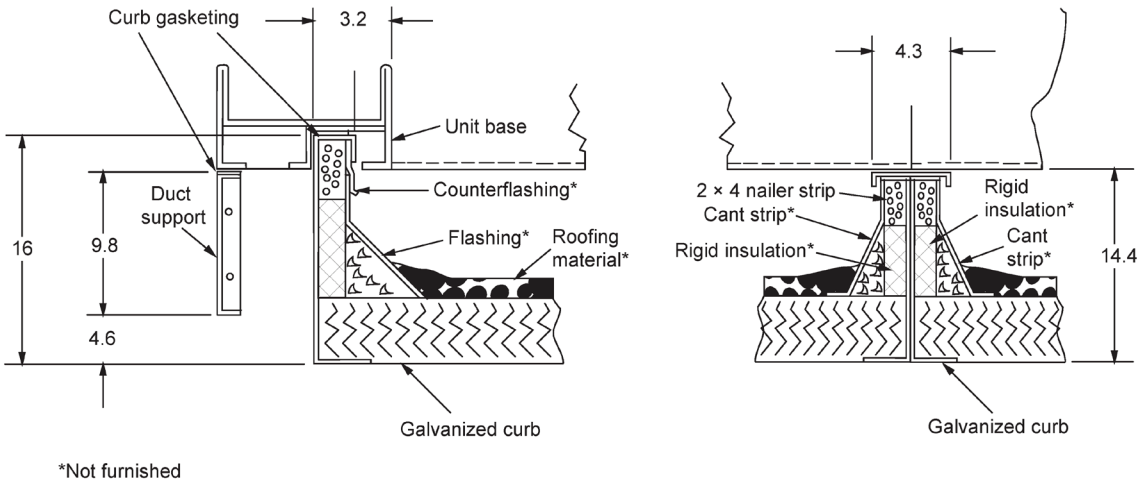
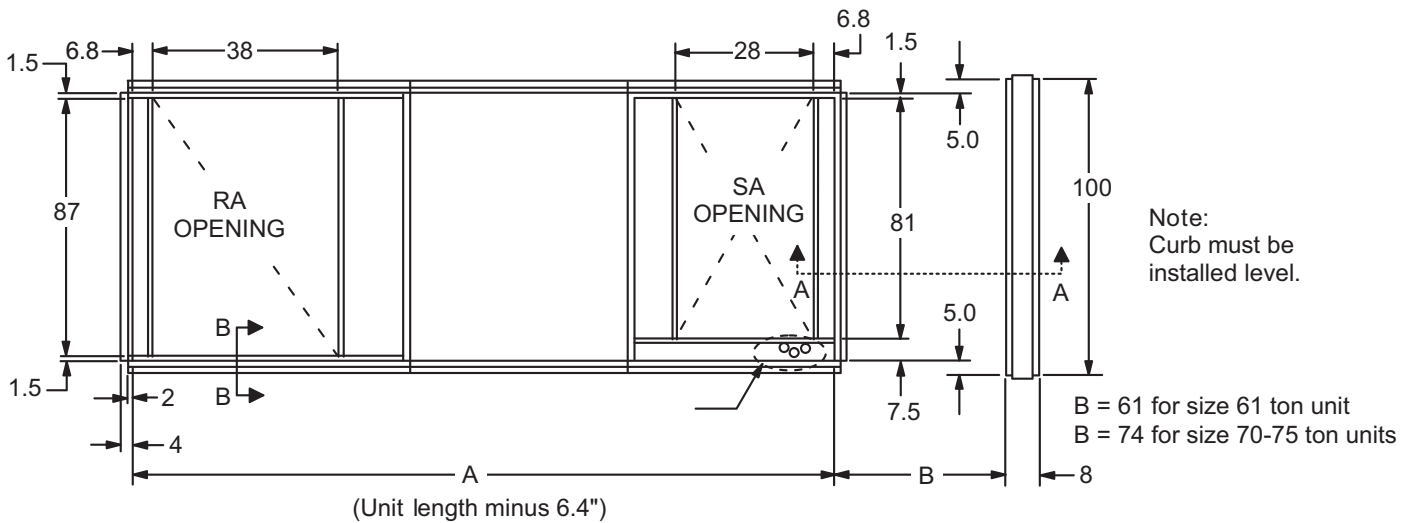
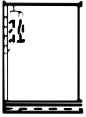

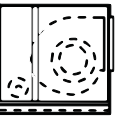
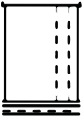

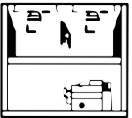
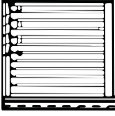

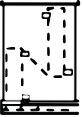
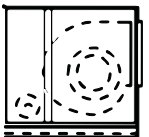

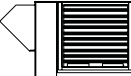

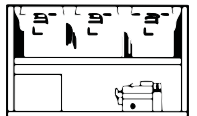

Figure 75: Roof Curb Dimensions



MPS 061–075 Section Dimensions

Figure 76: MPS 061–075 Gas or Electric Heat Section Dimensions







Position A Outdoor/ Return Air Mandatory	Position B Filter Mandatory	Position D DX Coil Mandatory	Position F Supply Air Fan Mandatory	Position G Heat Mandatory	Position K Discharge Plenum Mandatory	Position M Air-cooled Condensing Unit
<p>30% Outside Air</p>  <p>48</p>	<p>Angular</p>  <p>24</p>	<p>N/A on Size 70-75 (39.5 sq. ft.)</p>  <p>24</p>	<p>30" Dia</p>  <p>72</p>	<p>Electric</p>  <p>48</p>	<p>Discharge Plenum</p>  <p>48</p>	<p>Size 61 Air-cooled Condenser</p> 
<p>Economizer</p>  <p>72</p>	<p>Cartridge (40 sq. ft.)</p>  <p>24</p>	<p>(47.1 sq. ft.)</p>  <p>48</p>	<p>33" Dia</p>  <p>96</p>	<p>Gas</p>  <p>48</p>		<p>83 (Does not affect curb length)</p>
<p>Econ w/ Prop. Exh. Fans, Bottom or Back Ret.</p>  <p>72</p>	<p>Cartridge (48 sq. ft.)</p> 					<p>Size 70-75 Air-cooled Condenser</p>  <p>106 (Does not affect curb length)</p>

Example: MPS 061

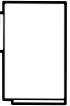
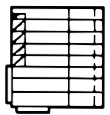
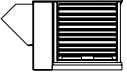
<u>Section Description</u>	<u>Length (in.)</u>
Bottom return economizer with exhaust air fan	= 72
Angular filters	= 24
Standard size cooling coil	= 24
Supply fan	= 72
Gas heat	= 48
Discharge plenum	= 48
Air cooled condensing unit	= 83
Total air handler length	= 288
<hr/>	
Total unit length (including condensing unit)	= 371

For a custom certified drawing of your specific requirements, consult your local Daikin Applied sales representative.

Figure 77: MPS 061–075 Cooling Only or Hot Water Section Dimensions

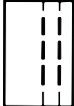
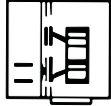
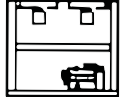
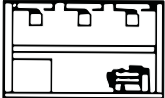
Exhaust/Return Air	Filter	DX Coil	Optional Heat	Supply Air Fan	Air-Cooled Condensing Unit
<p>30% OA  48 in.</p> <p>Economizer  72 in.</p> <p>Econ w/ Prop. Exh. Fans, Bottom or Back Ret. Fans  72</p>	<p>TA/30  24 in.</p> <p>65/95 40 ft²  24 in.</p> <p>65/95 48 ft²  48 in.</p>	<p>N/A on Size 70-75 40.1 ft²  24 in.</p> <p>47.4 ft²  48 in.</p>	<p>S&HW  48 in.</p>	<p>44 in. Dia  72 in.</p>	<p>Size 61  83 in. (Does not affect curb length)</p> <hr/> <p>Size 70-75  106 in. (Does not affect curb length)</p>

MPS 061-075 Knockout Dimensions

Figure 78: Main Control Panel/Discharge Plenum Knockouts

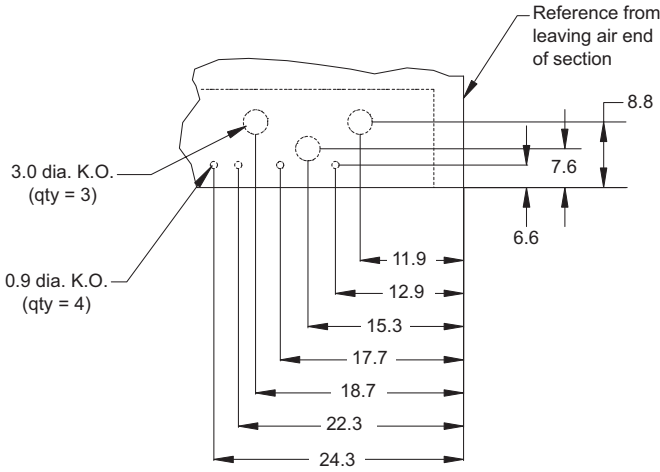

Figure 79: Main Control Panel/Discharge Plenum Knockout Detail

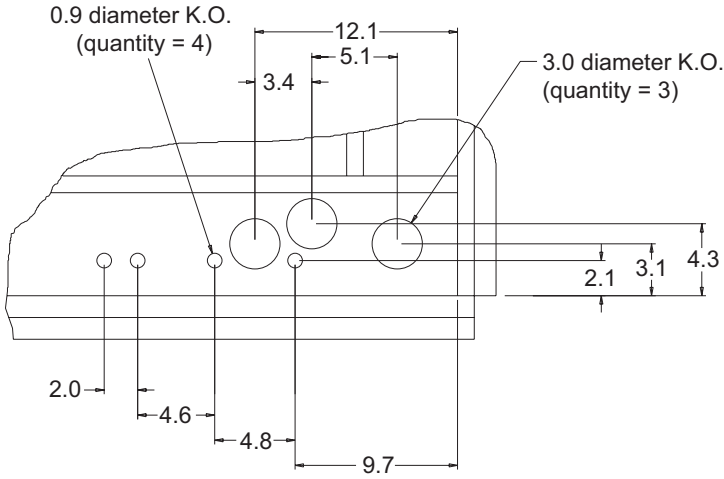
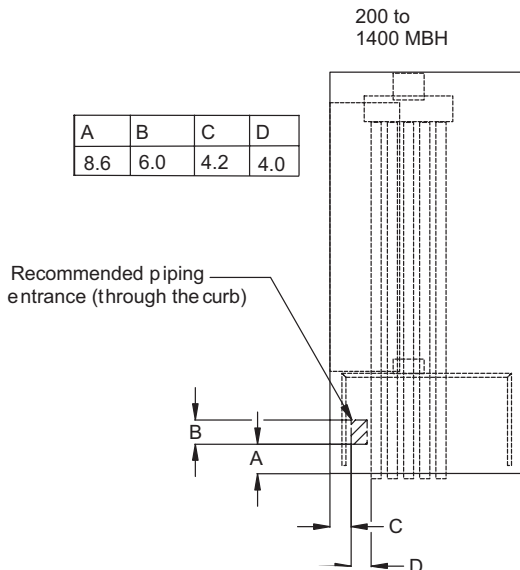

Figure 80: Gas Heat/Heat Section



Weight Data

MPS 015–050 Unit and Curb Weights

The following tables detail overall unit weight. [Figure 81](#) and [Figure 82 on page 81](#) details weight distribution percentages and loading point locations.

Table 25: Unit Base Weights

Unit (Tons)	Total Weight* (lbs)	Total Weight** (lbs)
015	2655	—
017	2705	—
020	3610	—
026	3610	3742
030	3610	3682
035	3660	3732
040	4685	4757
050	4985	5057

* Units with Fixed Speed Scroll Compressors

** Units with Variable Speed Scroll Compressors

Table 26: Unit Curb Weights

Unit (tons)	Curb Height (inches)	Total Weight (lbs)
Standard Unit		
015–035	14	341
	24	504
040–050	14	461
	24	706
Unit with Energy Wheel		
015–035	14	458
	24	674
040–050	14	619
	24	908

Table 27: Heat Section Weights

Unit (tons)	Weights (lbs)			
	High Gas Heat	Low Gas Heat	Electric Heat	Hot Water Heat
015	200	100	120	195
017	200	100	120	195
020	200	100	120	195
026, 030	270	135	270	291
035	270	135	270	291
040	350	175	350	307
050	350	175	350	307

Table 28: Energy Recovery Section Weights

Unit	Weight (lbs.)
015–020	1200
026–035	1540
040–050	1800

The following tables detail unit weights for the MPS 015–050 ton units.

MPS 015–050 Weight Distribution Percentage

Table 29: Weight Distribution by Percentage with Fixed Speed Scroll Compressors

Unit	Point and Percent of total							
	A	B	C	D	E	F	G	H
015–050 without Energy Wheel	11	11	20	24	16	18	N/A	N/A
015–035 with Energy Wheel	13	12	20	21	17	17	N/A	N/A
040–050 with Energy Wheel	12	12	13	13	12	12	13	13

Table 30: Weight Distribution by Percentage with Variable Speed Scroll Compressors

Unit	Point and Percent of total							
	A	B	C	D	E	F	G	H
015–050 without Energy Wheel	10	10	21	23	17	19	N/A	N/A
015–035 with Energy Wheel	12	11	21	20	18	18	N/A	N/A
040–050 with Energy Wheel	11	11	14	12	13	13	13	13

MPS 015–050 Weight Distribution Locations

Table 31: Weight Distribution Locations (see Figure 81)

Unit (Tons)	Distance		
	L1	L2	L3
015–035 Ton Unit	35.5	62.0	52.0
040–050 Ton Unit	40.0	69.0	89.0

Table 32: Weight Distribution Locations (see Figure 82)

Unit (Tons)	Distance			
	L1	L2	L3	L4
040–050 Ton Unit	42.2	66.6	58.3	60.9

Table 33: Curb Weights

Unit (Tons)/Curb Height	Weight (lbs)	
	without ERW	with ERW
015–035/14" Curb	341	458
015–035/24" Curb	501	674
040–050/14" Curb	481	619
040–050/24" Curb	708	908

Figure 81: Weight Distribution Locations and % of Total Load (MPS 030–035 Example)

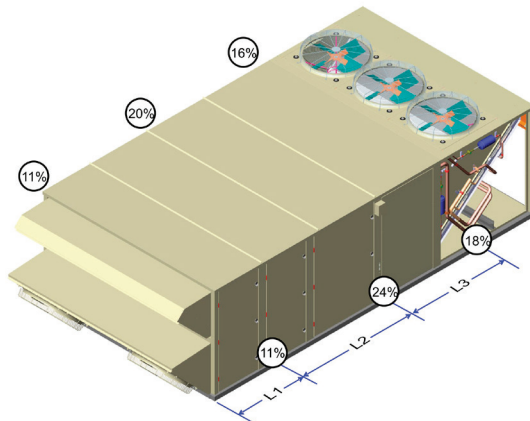
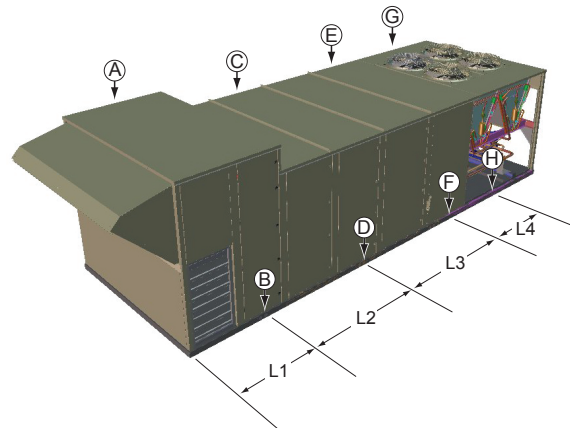

Figure 82: Weight Distribution Locations and % of Total



The following tables detail unit weights for the MPS 061–075 ton units.

MPS 061–075 Unit Weights

Table 34: MPS 061 to 075 (lbs.)

Components	Unit Size		
	061E	070E	075E
Unit Configuration			
MPS, basic unit*	5460	5720	5895
Outdoor/Return Air Options			
Return air plenum	Included in basic unit		
0–30% O.A. hood	222	222	222
0–100% economizer	1065	1065	1065
Filter Options			
30% pleated	4	4	4
65% cartridge—standard flow	57	57	57
65% cartridge—medium flow	538	538	538
95% cartridge—standard flow	67	67	67
95% cartridge—medium flow	550	550	550
Supply Air Fan Assembly			
Cooling only or hot water	1217	1217	1217
Gas or electric heat	965	965	965
Evaporator Coils—Aluminum Fins, Standard Airflow Face Area			
5-row, 10 fpi	559	N/A	N/A
Evaporator Coils—Aluminum Fins, High Airflow Face Area			
5-row, 10 fpi	1224	1224	1224
Hot Water Coil			
1-row	373	373	373
2-row	449	449	449
Electric Heat			
100 kW low capacity electric heat	1555	1555	1555
160 kW medium capacity electric heat	1575	1575	1575
200 kW high capacity electric heat	1600	1600	1600
Gas Heat			
400 MBh low fire furnace	1630	1630	1630
640 MBh medium fire furnace	1690	1690	1690
790 MBh high fire furnace	1780	1780	1780
Exhaust Air Fan Assembly			
1 fan, bottom or back return	525	525	525
2 fans, bottom or back return	785	785	785
Accessory Items			
Variable frequency drive—SAF	150	150	150
Insulation Liners			
2", 1.5 lbs., with solid liners: weight per foot of unit length	25	25	25

Note: Basic unit consists of return air plenum, angular filter section, supply air fan section without fan or motor, cooling section without coil, and condensing unit.

6-Row Coil and HGRH Coil Weights

Table 35: Coil Weights

Unit	Weight (lbs)	
	6 Row DX	HGRH
15–20	118	70
26–35	164	82
40	187	92
50	231	92

Fan Motor Weights

Table 36: Supply, Exhaust and Return Fan Motors

Motor hp	Totally Enclosed Weight (lbs)
5	85
7.5	140
10	170
15	235
20	300
25	330
30	390
40	510

Roof Curb Weights

Calculate the weight of the unit curb using the following equations:

Weight Formula

Base curb wt. (lb.) = 170 + 0.74 [170 + 2 × curb length (in.)] + additional weight (steps 1-3 below) as required

NOTE: Curb length does not include condenser length.

Additional Weights

- For bottom return opening, add 91 lbs.
- For bottom discharge opening, add 78 lbs.
- Cross supports:
 - For curb length greater than 288 in., add 30 lbs.

Example: MPS 070E with Gas Heat

Component	Lbs.
Basic unit	5,720
Economizer	1,065
30% efficiency filters	4
Supply fan	965
DX coil—high airflow	1,224
SAF motor—40 hp	510
Liners	650
= 10,138 lbs	

Liner calculations

Section	Lbs.
Economizer	6
Filter	2
Supply fan	6
Heat	4
DX coil	4
Discharge plenum	4

Total length of air handler 26 (feet) × 25 lbs. per ft.

= 650 lbs.

NOTE: For structural purposes, consider roof curb weight.

Electrical Data

Power Wiring

Table 37: Recommended Supply Data

Ampacity	Number of Power Wires per Phase/Wire Gauge			Insulation Rating (°C)
30	1-10			75
40	1-8			75
55	1-6			75
70	1-4			75
85	1-3			75
95	1-2			75
130	1-1			75
150	1-1/0			75
175	1-2/0			75
200	1-3/0			75
230	1-4/0			75
255	1-250			75
	MPS 015-020	MPS 026-050	MPS 061-075	MPS 015-075
300	2-1/0	2-1/0	1-300	75
350	2-2/0	2-2/0	1-400	75
400	2-3/0	2-3/0	2-3/0	75
460	2-4/0	2-4/0	2-4/0	75
510	2-250	2-250	2-250	75
600	3-3/0	3-3/0	2-350	75
690	3-4/0	3-4/0	2-400	75
765	3-250	3-250	2-500	75

Table 38: Condenser Fan Quantity Data

Unit Size	Condenser Fan Quantity
015-020	2
026-035	3
040-050	4
061-070	6
075	8

Table 39: Condenser Fan Motor Data

Voltage	Full Load Amps Per Condenser Fan Motor
208/230	4
460	2
575	1.7

Table 40: SAF Data and MPS 061-075 EAF Data

HP	Voltage	Amps
5	208	15.0
5	230	13.2
5	460	6.6
5	575	5.2
7.5	208	23.0
7.5	230	19.4
7.5	460	9.7
7.5	575	8.0
10	208	26.0
10	230	25.0
10	460	13.0
10	575	10.0
15	208	37.4
15	230	35.4
15	460	17.7
15	575	14.1
20	208	49.0
20	230	47.0
20	460	24.0
20	575	19.0
25	208	63.0
25	230	60.0
25	460	31.0
25	575	24.0
30	208	74.0
30	230	70.0
30	460	35.0
30	575	28.0
40	208	11.0
40	230	96.0
40	460	48.0
40	575	38.0

Table 41: MPS 015–050 Axial Propeller Exhaust Fan Data (MPS 061–075 use 1 or 2 5hp Motors - see Figure 50)

Size	Voltage	HP	Amps	Qty.	Total (Amps)
15	208	1	4.2	1	4.2
	230	1	4.0	1	4.0
	460	1	2.0	1	2.0
	575	1	1.7	1	1.7
17	208	1	4.2	1	4.2
	230	1	4.0	1	4.0
	460	1	2.0	1	2.0
	575	1	1.7	1	1.7
26	208	1	4.2	2	8.4
	230	1	4.0	2	8.0
	460	1	2.0	2	4.0
	575	1	1.7	2	3.4
30	208	1	4.2	2	8.4
	230	1	4.0	2	8.0
	460	1	2.0	2	4.0
	575	1	1.7	2	3.4
35	208	1	4.2	2	8.4
	230	1	4.0	2	8.0
	460	1	2.0	2	4.0
	575	1	1.7	2	3.4
40	208	1	4.2	3	12.6
	230	1	4.0	3	12.0
	460	1	2.0	3	6.0
	575	1	1.7	3	5.1
50	208	1	4.2	3	12.6
	230	1	4.0	3	12.0
	460	1	2.0	3	6.0
	575	1	1.7	3	5.1

Table 42: Energy Recovery Exhaust Fan

Cabinet	Application	Size (in [mm])	Motor HP	Quantity
15	Economizer	18 [457.2]	4.0	1
	30% OA	18 [457.2]	4.0	1
	100% OA	18 [457.2]	4.0	1
17	Economizer	22 [558.8]	8.0	1
	30% OA	18 [457.2]	4.0	1
	100% OA	18 [457.2]	4.0	1
20	Economizer	22 [558.8]	8.0	1
	30% OA	18 [457.2]	4.0	1
	100% OA	22 [558.8]	8.0	1
26, 30	Economizer	18 [457.2]	4.0	2
	30% OA	18 [457.2]	4.0	1
	100% OA	22 [558.8]	8.0	1
35	Economizer	22 [558.8]	8.0	2
	30% OA	22 [558.8]	8.0	1
	100% OA	22 [558.8]	8.0	1
40	Economizer	22 [558.8]	8.0	2
	30% OA	22 [558.8]	8.0	1
	100% OA	18 [457.2]	4.0	2
50	Economizer	22 [558.8]	8.0	2
	30% OA	22 [558.8]	8.0	1
	100% OA	22 [558.8]	8.0	2

Table 43: Energy Recovery Exhaust Fan Amps

Cabinet	Application	Voltage	Amps	Quantity	Total Amps
15/17	All	208/230	8.8	1	8.8
		460	4.0	1	4.0
		575	4.0	1	4.0
20	Economizer	208/230	13.5	1	13.5
		460	6.1	1	6.1
		575	6.1	1	6.1
	100% & 0-30% OA	208/230	8.8	1	8.8
		460	4.0	1	4.0
		575	4.0	1	4.0
26-35	Economizer	208/230	13.5	2	27.0
		460	6.1	1	6.1
		575	6.1	1	6.1
	0-30% OA	208/230	8.8	1	8.8
		460	4.0	1	4.0
		575	4.0	1	4.0
	100% OA	208/230	13.5	1	13.5
		460	6.1	1	6.1
		575	6.1	1	6.1
40	Economizer	208/230	13.5	2	27.0
		460	6.1	2	12.2
		575	6.1	2	12.2
	0-30% OA	208/230	13.5	1	13.5
		460	6.1	1	6.1
		575	6.1	1	6.1
	100% OA	208/230	8.8	1	8.8
		460	4.0	1	4.0
		575	4.0	1	4.0
50	Economizer & 100% OA	208/230	13.5	2	27.0
		460	6.1	2	12.2
		575	6.1	2	12.2
	0-30% OA	208/230	13.5	1	13.5
		460	6.1	1	6.1
		575	6.1	1	6.1

Table 44: Rated Load Amps Per Compressor, Units with Fixed Speed Scroll Compressors—MPS 015–050

Size	Voltage	Comp #1	Comp #2	Comp #3	Comp #4
15	208/230	25.0	23.1	—	—
	460	12.2	12.2	—	—
	575	9.3	8.7	—	—
17	208/230	25.0	27.6	—	—
	460	12.2	13.1	—	—
	575	9.3	11.5	—	—
20	208/230	17.3	39.1	17.3	—
	460	9.6	18.6	9.6	—
	575	7.7	15.4	7.7	—
26	208/230	25.0	25.0	25.0	—
	460	12.2	18.6	12.2	—
	575	9.3	9.3	9.3	—
30	208/230	39.1	27.6	27.6	—
	460	18.6	13.1	13.1	—
	575	15.4	11.5	11.5	—
35	208/230	39.1	39.1	27.6	—
	460	18.6	18.6	13.1	—
	575	15.4	15.4	11.5	—
40	208/230	39.1	39.1	27.6	27.6
	460	18.6	18.6	13.1	13.1
	575	15.4	15.4	11.5	11.5
50	208/230	39.1	39.1	39.1	39.1
	460	18.6	18.6	18.6	18.6
	575	15.4	15.4	15.4	15.4

Table 45: Rated Load Amps Per Compressor, Units with Variable Speed Scroll Compressors—MPS 026–050

Size	Voltage	Comp #1	Comp #2	Comp #3	Comp #4
26	208/230	25.0	37.2/33.6	25.0	—
	460	12.2	18.2	12.2	—
	575	9.3	16.8	9.3	—
30	208/230	47.2/42.5	27.6	27.6	—
	460	22.9	13.1	13.1	—
	575	20.6	11.5	11.5	—
35	230	42.5	39.1	27.6	—
	460	22.9	18.6	13.1	—
	575	20.6	15.4	11.5	—
40	208/230	47.5/42.5	39.1	27.6	27.6
	460	22.9	18.6	13.1	13.1
	575	20.6	15.4	11.5	11.5
50	208/230	47.0/42.5	39.1	39.1	39.1
	460	22.9	18.6	18.6	18.6
	575	20.6	15.4	15.4	15.4

Supply Power Wiring

Table 46: Rated Load Amps—MPS 061–075

Model	Voltage	Circuit 1		Circuit 2	
		RLA/comp	Comp Qty	RLA/comp	Comp Qty
061	208-60-3	56.7	2	56.7	2
	230-60-3	51.3	2	51.3	2
	460-60-3	23.1	2	23.1	2
	575-60-3	19.9	2	19.9	2
070	208-60-3	36.8	3	36.8	3
	230-60-3	33.3	3	33.3	3
	460-60-3	17.9	3	17.9	3
	575-60-3	12.8	3	12.8	3
75	208-60-3	53.2	3	53.2	3
	230-60-3	48.1	3	48.1	3
	460-60-3	18.6	3	18.6	3
	575-60-3	14.7	3	14.7	3

Data Electric Heater Data

Table 47: MPS 020–050 Electric Heater Data

kW	Voltage	Amps
18	208	50
18	230	45
18	460	23
18	575	18
36	208	100
36	230	90
36	460	45
36	575	36
54	208	150
54	230	130
54	460	65
54	575	52
72	208	200
72	230	173
72	460	86
72	575	70
90	208	250
90	230	217
90	460	108
90	575	87
108	460	130
108	575	104

Table 48: MPS 061–075 Electric Heat Data

Model	208/60/3			240/60/3			480/60/3			600/60/3		
	kW	FLA	Stages	kW	FLA	Stages	kW	FLA	Stages	kW	FLA	Stages
100	74.7	207.4	4	99.5	239.4	4	99.5	119.7	4	99.5	95.7	4
160	119.7	332.0	4	159.2	383.0	4	159.2	191.5	4	159.2	153.2	4
200	—	—	—	—	—	—	199.0	239.4	4	199.0	191.5	4

The following formulas can be used to calculate Minimum circuit Ampacity (MCA) and Maximum Rated Overcurrent Protection Device (MROPD).

Cooling Only/Cooling with Gas Heat/Hot Water Heat

MCA = 1.25 x current draw of largest motor/compressor + current draw of the rest of the motors/compressors + 1 (controls).

MROPD = 2.25 x current draw of largest motor/compressor + current draw of the rest of motors/compressors + 1 (controls).

Elect. Heat (sizes 15–70 and size 75 with 160–200kW)

MCA = 1.25 x (supply fan motor amps + exhaust fan motor amps + transformer) + electric heat load.

MROPD = 2.25 (largest fan motor) + electric heat load + remaining fan motor + transformer.

Electric Heat (Size 75, 100 kW)

MCA = 1.25 x current draw of largest motor/compressor + current draw of the rest of the motors/compressors + 1 (controls).

MROPD = 2.25 x current draw of largest motor/compressor + current draw of the rest of motors/compressors + 1 (controls)

Engineering Guide Specifications

Part 1: General

1.01 Section Includes:

- A. Packaged rooftop air conditioners.

1.02 References

- A. AFBMA 9-Load Ratings and Fatigue Life for Ball Bearings.
- B. AMCA 99-Standards Handbook.
- C. AMCA 210-Laboratory Methods of Testing Fans for Rating Purposes.
- D. AMCA 300-Test Code for Sound Rating Air Moving Devices.
- E. AMCA 500-Test Methods for Louver, Dampers, and Shutters.
- F. ARI 410-Forced-Circulation Air-Cooling and Air-Heating Coils.
- G. ARI 430-Central-Station Air-Handling Units.
- H. ARI 435-Application of Central-Station Air-Handling Units.
 - I. IBC 2000 - International Building Code.
 - J. NEMA MG1-Motors and Generators.
 - K. National Electrical Code.
 - L. NFPA 70-National Fire Protection Agency.
 - M. SMACNA-HVAC Duct Construction Standards-Metal and Flexible.
 - N. UL 900-Test Performance of Air Filter Units.

1.03 SUBMITTALS

- A. Shop Drawings: Indicate assembly, unit dimensions, weight loading, required clearances, construction details, field connection details, electrical characteristics and connection requirements.
- B. Product Data:
 1. Provide literature that indicates dimensions, weights, capacities, ratings, fan performance, and electrical characteristics and connection requirements.
 2. Provide computer generated fan curves with specified operating point clearly plotted.
 3. Manufacturer's installation instructions.

1.04 Operation And Maintenance Data

- A. Maintenance Data: Provide instructions for installation, maintenance and service.

1.05 Qualifications

- A. Manufacturer: Company specializing in manufacturing the Products specified in this section with minimum five years documented experience, who issues complete catalog data on total product.
- B. Startup must be done by trained personnel experienced with rooftop equipment.
- C. Do not operate units for any purpose, temporary or permanent, until ductwork is clean, filters and remote controls are in place, bearings lubricated, and manufacturers' installation instructions have been followed.

1.06 Delivery, Storage, And Handling

- A. Deliver, store, protect and handle products to site.
- B. Accept products on site and inspect for damage.
- C. Store in clean dry place and protect from weather and construction traffic. Handle carefully to avoid damage to components, enclosures, and finish.

Part 2: Products

2.01 Manufacturers

- A. Basis of Design: Daikin Applied
 1. Daikin Applied.
 2. Trane.
 3. Carrier.
 4. York.
 5. AAON.

2.02 General Description

- A. Furnish as shown on plans, Daikin Applied Maverick Singlezone Heating and Cooling Unit(s) model MPS. Unit performance and electrical characteristics shall be per the job schedule.

- B. Configuration: Fabricate as detailed on prints and drawings:
 1. Return plenum/economizer section.
 2. Filter section.
 3. Cooling coil section.
 4. Supply fan section.
 5. Gas heating section.
 6. Electric heating section.
 7. Hot water heating section.
 8. Condensing unit section.
- C. The complete unit shall be cETLus/MEA listed.
- D. The burner and gas train for the unit furnace shall be cETLus approved.
- E. Each unit shall be specifically designed for outdoor rooftop application and include a weatherproof cabinet. Each unit shall be completely factory assembled and shipped in one piece. MPS packaged units shall be shipped fully charged with Refrigerant 410A and oil.
- F. The unit shall undergo a complete factory run test prior to shipment. The factory test shall include final balancing of the supply fan assemblies, a refrigeration circuit run test, a unit control system operations checkout, a unit refrigerant leak test and a final unit inspection.
- G. All units shall have decals and tags to indicate caution areas and aid unit service. Unit nameplates shall be fixed to the main control panel door. Electrical wiring diagrams shall be attached to the control panels. Installation, operating and maintenance bulletins and start-up forms shall be supplied with each unit.
- H. Performance: All scheduled capacities and face areas are minimum accepted values. All scheduled amps, kW, and HP are maximum accepted values that allow scheduled capacity to be met.
- I. Warranty: The manufacturer shall provide 12-month parts only warranty. Defective parts will be repaired or replaced during the warranty period at no charge. The warranty period shall commence at startup or six months after shipment, whichever occurs first.

2.03 Cabinet, Casing, And Frame

- A. Panel construction shall be double-wall construction for all panels. All floor panels shall have a solid galvanized steel inner liner on the air stream side of the unit to protect insulation during service and maintenance. Insulation shall be a minimum of 1" thick with an R-value of [4.0 on MPS 015–050 ton units] [6.5 on MPS 061–075 ton units], and shall be neoprene coated glass fiber. Panel design shall include no exposed insulation edges. Unit cabinet shall be designed to operate at total static pressures up to [5.0 on sizes 020–050] [6.5 on sizes 061–075] inches w.g.
- B. Double wall construction shall be the minimum design in all sections down stream of the cooling coil section. This shall include the fan, gas heat, and discharge plenum sections as a minimum.
- C. Exterior surfaces shall be constructed of painted galvanized steel, for aesthetics and long-term durability. Paint finish will include a base primer with a high-quality polyester resin topcoat. Finished, unabraded panel surfaces shall be exposed to an ASTM B117 salt spray environment and exhibit no visible red rust at a minimum of 3,000 hours exposure. Finished, abraded surfaces shall be tested per ASTM D1654, having a mean scribe creepage not exceeding 1/16" at 1,000 hours minimum exposure to an ASTM B117 salt spray environment. Measurements of results shall be quantified using ASTM D1654 in conjunction with ASTM D610 and ASTM D714 to evaluate blister and rust ratings.
- D. Service doors shall be provided on both sides of the fan section, coil section, economizer section, control panel, and the filter section in order to provide user access to unit components. All service access doors shall be mounted on multiple, stainless steel hinges and shall be secured by a latch system. Removable service panels secured by multiple mechanical fasteners are not acceptable.
- E. The unit base shall overhang the roof curb for positive water runoff and shall seat on the roof curb gasket to provide a positive, weathertight seal. Lifting brackets shall be provided on the unit base to accept cable or chain hooks for rigging the equipment.

2.04 Supply Fan

- A. Supply fan shall be a [SWSI airfoil centrifugal fan] [DWDI on sizes 061–075 with gas or electric heat]. The fan blade design shall be a double blade with the airfoil geometry, a backward inclined blade fan wheel design will not be acceptable. The fan wheel shall be Class II construction with steel fan blades welded to the back plate and end rim. The supply fan shall be mounted using solid-steel shafts and wheel hubs with mating keyways.

- B. The fan assembly shall have fixed pitched drives with a minimum of two belts. The drives shall be selected with a minimum diameter of 4 inches and a 1.2 service factor. The belts shall be of the grip-notch design.
- C. All fan assemblies shall be statically and dynamically balanced at the factory, including a final trim balance, prior to shipment. All fan assemblies shall employ solid steel fan shafts. Heavy-duty concentric locking pillow block type, self-aligning, grease lubricated ball bearings shall be used. Bearings shall be sized to provide a L-50 life at 250,000 hours. The entire fan assembly shall be isolated from the fan bulkhead and mounted on spring isolators [1" on sizes 015–050] [2" on sizes 061–075].
- D. Fan motors shall be heavy-duty 1800 rpm open drip-proof (ODP) type with grease lubricated ball bearings. Motors shall be premium efficiency. Motors shall be mounted on an adjustable base that provides for proper alignment and belt tension adjustment. Motors shall be suitable for use with a variable frequency drive.
- E. The supply fan shall be capable of airflow modulation from 30% to 100% of the scheduled designed airflow. The fan shall not operate in a state of surge at any point within the modulation range.

2.05 Exhaust Fan

- A. Exhaust fans shall be provided. Blades shall be constructed with fabricated steel and shall be securely attached to fan shafts. All exhaust fan assemblies shall be statically and dynamically balanced. Motors shall be permanently lubricated, heavy-duty type, carefully matched to the fan load. Ground and polished steel fan shafts shall be mounted in permanently lubricated and sealed ball bearings. Bearings shall be selected for a minimum (L10) life in excess of 100,000 hours at maximum cataloged operating speeds.
- B. The unit DDC controller shall provide building static pressure control. A factory mounted exhaust fan variable frequency drive shall provide proportional control of the exhaust fans from 25% to 80% of the supply air fan designed airflow. The field shall mount the required sensing tubing from the building to the factory mounted building static pressure sensor.

2.06 Variable Air Volume Control

- A. An electronic variable frequency drive shall be provided for the supply air fan. Each drive shall be factory installed in a conditioned cabinet. Drives shall meet UL Standard 95-5V. The completed unit assembly shall be listed by a recognized safety agency, such as ETL. Drives are to be accessible through a hinged door assembly. Mounting arrangements that expose drives to high temperature unfiltered ambient air are not acceptable.
- B. The unit manufacturer shall install all power and control wiring.
- C. The supply air fan drive output shall be controlled by the factory installed main unit control system and drive status and operating speed shall be monitored and displayed at the main unit control panel.

2.07 Electrical

- A. Unit wiring shall comply with NEC requirements and with all applicable UL standards. All electrical components shall be UL recognized where applicable. All wiring and electrical components provided with the unit shall be number and color-coded and labeled according to the electrical diagram provided for easy identification. The unit shall be provided with a factory wired weatherproof control panel. Unit shall have a single point power terminal block for main power connection. A terminal board shall be provided for low voltage control wiring. Branch short circuit protection, 115-volt control circuit transformer and fuse, system switches, and a high temperature sensor shall also be provided with the unit. Each compressor and condenser fan motor shall be furnished with contactors and inherent thermal overload protection. Supply fan motors shall have contactors and external overload protection. Knockouts shall be provided in the bottom of the main control panels for field wiring entrance.
- B. A single non-fused disconnect switch shall be provided for disconnecting electrical power at the unit. Disconnect switches shall be mounted internally to the control panel and operated by an externally mounted handle.
- C. A GFI receptacle shall be unit mounted. The receptacle will require a field power connection independent from the unit's main power block and/or disconnect.
- D. A GFI receptacle shall be unit mounted. The receptacle shall be powered by a factory installed and wired 120 V, 20 amp power supply. The power supply shall be wired to the line side of the unit's main disconnect, so the receptacle is powered when the main unit disconnect is off. This option shall include a GFI receptacle, transformer, and a branch circuit disconnect. The electrical circuit shall be complete with primary and secondary overload protection.
- E. A factory-installed phase monitor shall protect the unit from low voltage, phase imbalance and phase reversal [optional on size 061–075].

2.08 Cooling Section

- A. The cooling coil section shall be installed in a draw through configuration, upstream of the supply air fan. The coil section shall be complete with a factory piped cooling coil and an ASHRAE 62.1 compliant sloped drain pan.
- B. Direct expansion (DX) cooling coils shall be fabricated of seamless high efficiency copper tubing that is mechanically expanded into high efficiency aluminum plate fins. Coils shall be a multi-row, staggered tube design with a minimum of 4 rows and a maximum of 12 fins per inch. All units shall have two independent refrigerant circuits and shall use an interlaced coil circuiting that keeps the full coil face active at all load conditions. All coils shall be factory leak tested with high pressure air under water.
- C. [Optional] Direct expansion (DX) cooling coils shall be fabricated of seamless high efficiency copper tubing that is mechanically expanded into high efficiency aluminum plate fins. Coils shall be a multi-row, staggered tube design with a minimum of 6 rows for maximum dehumidification effect. All units shall have two independent refrigerant circuits and shall use an interlaced coil circuiting that keeps the full coil face active at all load conditions. All coils shall be factory leak tested with high pressure air under water.
- D. A stainless steel positively sloped drain pan shall be provided with the cooling coil. The drain pan shall extend beyond the leaving side of the coil. The drain pan shall have a minimum slope of 1/8" per foot to provide positive draining. The slope of the drain pan shall be in two directions and comply with ASHRAE Standard 62.1 The drain pan shall be connected to a threaded drain connection extending through the unit base.

2.09 Staged Gas Heating Section

- A. The rooftop unit shall include a natural gas heating section. The gas furnace design shall be one or more natural gas fired heating modules factory installed downstream of the supply air fan in the heat section. Each module shall have two stages of heating control. The heating module shall be a tubular design with in-shot gas burners. The heat exchanger tubes shall be constructed of 20 ga, G160, aluminized steel. The module shall have an induced draft fan that will maintain a negative pressure in the heat exchanger tubes for the removal of the flue gases.
- B. Each burner module shall have two flame roll-out safety protection switches and a high temperature limit switch that will shut the gas valve off upon detection of improper burner manifold operation. The induced draft fan shall have an airflow safety switch that will prevent the heating module from turning on in the event of no airflow in the flue chamber.
- C. The factory-installed DDC unit control system shall control the gas heat module. Field installed heating modules shall require a field ETL certification. The manufacturer's rooftop unit ETL certification shall cover the complete unit including the gas heating modules.
- D. The heating modules shall have a field installed kit for conversion of the unit to LP gas.

2.10 Modulating Gas Heating Section

- A. [015–050 Low Capacity] The rooftop unit shall include a natural gas heating section. The gas furnace design shall have a natural gas fired heating module factory installed downstream of the supply air fan in the heat section. The module shall be complete with furnace controller and control valve capable of modulating operation from 100% down to 28% of full fire capacity. The heating module shall be a tubular design with in-shot gas burners. The heat exchanger tubes shall be constructed of stainless steel. The module shall have an induced draft fan that will maintain a negative pressure in the heat exchanger tubes for the removal of the flue gases.

- B. [015–050 High Capacity] The rooftop unit shall include a natural gas heating section. The section design shall be two natural gas fired heating modules factory installed downstream of the supply air fan in the heat section. One module shall have two stages of capacity control. The other module shall be complete with furnace controller and control valve capable of modulating operation from 100% down to 14% of the unit’s total full fire capacity. The heating modules shall be a tubular design with in-shot gas burners. The heat exchanger tubes shall be constructed of stainless steel. The module shall have an induced draft fan that will maintain a negative pressure in the heat exchanger tubes for the removal of the flue gases.
- C. Each 015–050 size burner module shall have two flame roll-out safety protection switches and a high temperature limit switch that will shut the gas valve off upon detection of improper burner manifold operation. The induced draft fan shall have an airflow safety switch that will prevent the heating module from turning on in the event of no airflow in the flue chamber.
- D. Each 061–075 natural gas fired furnace shall be installed in the unit heat section. The heat exchanger shall include a type 321 stainless steel cylindrical primary combustion chamber, a type 321 stainless steel header, type 321 stainless steel secondary tubes and type 321 stainless steel turbulators. The heat exchanger shall have a condensate drain. Clean out of the primary heat exchanger and secondary tubes shall be accomplished without removing casing panels or passing soot through the supply air passages. The furnace section shall be positioned downstream of the supply air fan to maintain positive pressure around the heat exchanger.

The furnace will be supplied with a modulating forced draft burner. The burner shall be controlled for low fire start. The burner shall be capable of continuous modulation between 33% and 100% of rated capacity and shall operate efficiently at all firing rates.

The burner shall be specifically designed to burn natural gas and shall include a microprocessor based flame safeguard control, combustion air proving switch, pre-purge timer and spark ignition. The gas train shall include redundant gas valves, maximum 0.5psi pressure regulator, shutoff cock, pilot gas valve, pilot pressure regulator, and pilot cock.

- E. The burner shall be rated for operation and full modulation capability at inlet gas pressures down to 7.5 W.C.

Unit Size	Staged Heat	Modulating Heat
015–050	7–14" w.c.	10–14" w.c.
061–075	—	7.5–13.5" w.c.

- F. The factory-installed DDC unit control system shall control the gas heat module. Field installed heating modules shall require a field ETL certification. The manufacturer’s rooftop unit ETL certification shall cover the complete unit including the gas heating modules.

2.11 Electric Heating Section

- A. Heating coils shall be constructed of a low watt density, high nickel chromium alloy resistance wire, mechanically stacked and heli-arc welded to corrosion resistant terminals. A corrosion resistant heavy gauge rack shall support the elements. Safety controls shall include automatic reset high limit control with manual reset backup line break protection. Heating element branch circuits shall be fused to maximum of 48 Amps per NEC requirements.
- B. The electric heat section shall be positioned downstream of the supply air fan.
- C. Proof of airflow must be established any time the electric heat element is energized.
- D. The electric heat elements shall be controlled by the factory installed main unit DDC control system. The control system will have four distinct stages of heating on any unit over 25 tons. Each stage control contactor shall be a three pole contactor. When the stage control contactor is not energized, it must break all three phases of power input to the electric heater.
- E. The electrical power supply for the electric heater shall be from the rooftop unit control panel. Unit shall have a single point power supply connection. Independent supply power connection to the electric heater will not be accepted.
- F. All disconnects must be three pole to remove power from all incoming legs.

2.12 Hot Water Heating Section

- A. A [1] [2] row hot water heating coil shall be factory installed in the unit heat section. Coils shall be fabricated of seamless 5/8" diameter copper tubing that is mechanically expanded into high efficiency rippled and corrugated aluminum plate fins. All coil vents and drains shall be factory installed. The hot water heat section shall be installed downstream of the supply air fan. A factory-tested diffuser shall be used in order to provide air distribution across the coil.
- B. Hot water coil shall be fully cased to allow for easy replacement.
- C. Factory shall provide a field piping vestibule. The control valve shall be field supplied and installed in the unit heater vestibule. The control valve shall be capable of receiving a 2 - 10 VDC signal. Connection holes through the base of the unit in the field piping vestibule shall be cut and sealed by the field.
- D. All coil connections shall be copper, steel connections shall not be allowed in order to prevent dielectrics and corrosion.
- E. Fluid pressure drop shall conform to the mechanical schedule.
- F. Freeze protection by the DDC controller and use the discharge air sensor. DDC controller shall be capable of sending an alarm signal.
- G. Coil shall be factory leak tested with high pressure air under water.

2.13 Modulating Hot Gas Reheat Coil Section

- A. Unit shall be equipped with a hot gas reheat coil with hot gas coming from the unit condenser.
- B. The hot gas reheat option shall have a fully modulated control to allow for unit leaving air temperature control to +/- 2°.
- C. The modulating hot gas reheat systems shall allow for independent control of the cooling coil leaving air temperature and the reheat coil leaving air temperature. The cooling and reheat leaving air temperature setpoints shall be adjustable through the unit MicroTech controller.
- D. Hot gas coil shall be an all aluminum design. The aluminum tube shall be a micro channel design with high efficiency aluminum fins. Fins shall be brazed to the tubing for a direct bond. Each condenser coil shall be factory leak tested with high-pressure air under water.
- E. Hot gas coil shall be sized to allow for full condensing across the operation range of the unit. High temperature liquid shall be piped downstream of the unit's condenser coils into the liquid line.
- F. The refrigeration circuit shall not require receivers. The hot gas coil shall be used for refrigerant storage when the unit is not operation in a dehumidification or reheat mode.

Hot Gas Reheat Coil Section

- A. Unit shall be equipped with a hot gas reheat coil with hot gas coming from the unit condenser.
- B. Hot gas coil shall be an all aluminum design. The aluminum tube shall be a micro channel design with high efficiency aluminum fins. Fins shall be brazed to the tubing for a direct bond. Each condenser coil shall be factory leak tested with high-pressure air under water.
- C. Hot gas coil shall be sized to allow for full condensing across the operation range of the unit. High temperature liquid shall be piped downstream of the unit's condenser coils into the liquid line.
- D. The refrigeration circuit shall not require receivers. The hot gas coil shall be used for refrigerant storage when the unit is not operation in a dehumidification or reheat mode.

2.14 Filters

Draw-Through Filters

- A. Sizes 020–050 shall be provided with a draw-through filter section. The filter rack shall be designed to accept a 2" prefilter and a 4" final filter. The unit design shall have a hinged access door for the filter section. The manufacturer shall ship the rooftop unit with 2" MERV 8 construction filters. The contractor shall furnish and install, at building occupancy, the final set of filters per the contract documents.
- B. Size 061–075 ton units shall be provided with a draw-through filter section. The filter section shall be supplied complete with the filter rack as an integral part of the unit. The draw-through filter section shall be provided with [panel] [cartridge] filters.
- C. Panel filters on size 061–075 units shall be 2" thick AmericanAirFilter 30% efficient MERV 8 pleated panel filters. Filters shall be frame mounted and shall slide into galvanized steel racks contained within the unit. Filters shall be installed in an angular arrangement to maximize filter area and minimize filter face velocity. Filters shall be accessible from both sides of the filter section.
- D. Cartridge filters on size 061–075 ton units shall have [12" deep [60–65%] [90–95%] efficient, UL Std. 900, Class 1, AmericanAirFilter cartridge filters. 2" panel, 30% efficient MERV 8 pre-filters shall be included. Cartridge filters shall consist of filter media permanently attached to a metal frame and shall slide into a gasketed, extruded aluminum rack contained within the unit. The filter rack shall have secondary gasketed, hinged end panels to insure proper sealing. Filters shall be accessible from both sides of the filter section.

2.15 Outdoor/Return Air Section

- A. Sizes 015–050 shall be provided with an outdoor air economizer section. The 0 to 100% outside air economizer section shall include outdoor, return, and exhaust air dampers. The outdoor air hood shall be factory installed and constructed from galvanized steel finished with the same durable paint finish as the main unit. The hood shall include moisture eliminator filters to drain water away from the entering air stream. The outside and return air dampers shall be sized to handle 100% of the supply air volume. The dampers shall be opposed blade design. All dampers are low-leak with blade and side seals. Leakage rates are only 1.5 cfm/ft² of the damper area at 1" differential pressure. Leakage rate to be tested in accordance with AMCA Standard 500.
- B. Sizes 061–075 shall be provided with an outdoor air economizer section. The 0 to 100% outside air economizer section shall include outdoor, return, and exhaust air dampers. Outdoor air shall enter from both sides of the economizer section through horizontal, louvered intake panels complete with rain lip and bird screen. The floor of the outdoor air intakes shall provide for water drainage. The economizer section shall allow return air to enter from the [bottom] [back] of the unit.

The outside and return air dampers shall be sized to handle 100% of the supply air volume. The dampers shall be opposed sets of parallel blades, arranged vertically to converge the return air and outdoor air streams in multiple, circular mixing patterns. Daikin Applied UltraSeal™ low leak dampers shall be provided. All dampers are low-leak with blade and side seals. Leakage rates are only 1.5 cfm/ft² of the damper area at 1" differential pressure. Leakage rate to be tested in accordance with AMCA Standard 500. Damper blades shall be operated from multiple sets of linkages mounted on the leaving face of the dampers.

- C. A barometric exhaust damper shall be provided to exhaust air out of the back of the unit. A bird screen shall be provided to prevent infiltration of rain and foreign materials. Exhaust damper blades shall be lined with vinyl gasketing on contact edges.
- D. Control of the OA/RA dampers shall be by a factory installed direct coupled actuator. Damper actuator shall be of the modulating, spring return type. An adjustable dry bulb control shall be provided to sense the dry-bulb temperature of the outdoor air stream to determine if outdoor air is suitable for "free" cooling. If outdoor air is suitable for "free" cooling, the outdoor air dampers shall modulate in response to the unit's temperature control system.
- E. A return air plenum shall be provided with a 0 to 30% outdoor air hood. The hood shall allow outdoor air to enter at the back of the return air plenum. The outdoor air hood shall be factory installed and constructed from galvanized steel finished with the same durable paint finish as the main unit. The hood shall include moisture eliminator filters to drain water away from the entering air stream. The return air plenum shall allow return air to enter from the bottom of the unit. The outdoor air damper shall be controlled by a factory installed direct coupled actuator. The unit controller shall control the actuator to an outdoor air position setpoint that is adjustable from 0 to 30%. Upon unit shut down during unoccupied periods the outdoor air damper shall be power driven closed.
- F. Provide factory installed and tested, outdoor air monitor that controls outdoor air +/- 15% accuracy down to 40 cfm per ton.

2.16 100% Outdoor Section

- A. Unit shall be equipped with a low leak OA damper. OA shall enter the unit through the end of the unit and shall have hoods sized to prevent water carry over during inclement weather. Damper shall be controlled with a modulating, direct coupled actuator to allow for field adjustment of unit airflow.
- B. All dampers are low-leak with blade and side seals. Leakage rates are only 1.5 cfm/ft² of the damper area at 1" differential pressure. Energy Standard. Leakage rate to be tested in accordance with AMCA Standard 500. Damper blades shall be operated from multiple sets of linkages mounted on the leaving face of the dampers.

2.17 Condensing Section

- A. Condenser coils shall be an all aluminum design. The aluminum tube shall be a micro channel design with high efficiency aluminum fins. Fins shall be brazed to the tubing for a direct bond. Each condenser coil shall be factory leak tested with high-pressure air under water. Condenser coils shall be protected from incidental contact to coil fins by a coil guard. Coil guard shall be constructed of cross wire welded steel with PVC coating.
- B. Condenser fans shall be direct drive, axial type designed for low tip speed and vertical air discharge. Condenser fan rpm shall be 1140 rpm maximum. Fan blades shall be constructed of steel and riveted to a steel center hub. Condenser fan motors shall be heavy-duty, inherently protected, three-phase, non-reversing type with permanently lubricated ball bearing and integral rain shield.
- C. Each circuit shall have fan cycling of at least one condenser fan to maintain positive head pressure. An ambient thermostat shall prevent the refrigeration system from operating below [0°F on sizes 015–050] [45°F on sizes 061–075] [0°F on sizes 061–075 with VFD on condenser fan] [35°F on sizes 030–035, 0°F on sizes 040–050 with variable speed scroll compressor].
- D. Condenser coils shall be protected from hail damage as an integral part of the unit design. Hail guards shall be provided on all units with vertical mounted condenser coils.
- E. Each unit shall have multiple, heavy-duty scroll compressors. Each compressor shall be complete with gauge ports, crankcase heater, sight-glass, anti-slug protection, motor overload protection and a time delay to prevent short cycling and simultaneous starting of compressors following a power failure. Compressors shall be isolated with resilient rubber isolators to decrease noise transmission.
- F. Each unit shall have two independent refrigeration circuits. Each circuit shall be complete with a low pressure control, filter-drier, thermal expansion valve, and a manual reset high pressure safety switch. The thermal expansion valve shall be capable of modulation from 100% to 25% of its rated capacity. Sight-glasses shall be accessible for viewing without disrupting unit operation. Each circuit shall be dehydrated and factory charged with Refrigerant 410A and oil.
- G. **Variable Speed Scroll Compressor (N/A on all sizes)**
Each unit shall have multiple compliant fixed speed scroll compressors and one variable speed scroll compressor. All compressors shall be isolated with resilient rubber isolators to decrease noise transmission.

The lead compressor shall be driven by variable frequency drive to control compressor speed. The compressor speed shall dynamically vary to match the space load. The minimum unit capacity shall be 20% of full load. The variable speed scroll compressor motor shall be a brushless permanent magnet type, to provide higher efficiency at all speeds. Oil injection system shall be provided to ensure optimal efficiencies. Gearotor oil pump shall be provided for exceptional bearing lubrication at all compressor speed. Oil Strainer shall be provided to control the risk of system debris in the oil injection circuit. Each variable speed scroll compressor shall be engineered with an appropriate sized VFD to control compressor motor speed and to provide compressor protection functions. Crankcase heating shall be provided (via a DC holding current through the motor windings) to prevent refrigerant migration and mixing with crankcase oil when the compressor is not in operation. Current sensing, motor temperature sensing, and motor overload protection, a time delay to prevent short cycling and simultaneous starting of compressors following a power failure is provided.

Each fixed speed compressor shall include crankcase heater, sight-glass, current sensing and motor temperature sensing, motor overload protection and a time delay to prevent short cycling and simultaneous starting of compressors following a power failure.

2.18 Roof Curb

- A. A prefabricated 14-gauge galvanized steel, mounting curb shall be provided for field assembly on the roof decking prior to unit shipment.
- B. The size 015–050 roof curb shall be a full perimeter type with complete perimeter support of the air handling section and condensing section.
- C. The size 061–075 roof curb shall provide complete perimeter support of the air handling section and rail support of the condensing section. Supply and return opening duct frames shall be provided as part of the curb structure allowing duct connections to be made directly to the curb prior to unit arrival.
- D. The curb shall be a minimum of 14" high and include a nominal 2" x 4" wood nailing strip. Gasket shall be provided for field mounting between the unit base and roof curb.

2.19 Controls

- A. Provide a complete integrated microprocessor based Direct Digital Control (DDC) system to control all unit functions including temperature control, scheduling, monitoring, unit safety protection, including compressor minimum run and minimum OFF times, and diagnostics. This system shall consist of all required temperature sensors, pressure sensors, controller and keypad/display operator interface. All MCBs and sensors shall be factory mounted, wired and tested.

- B. The stand-alone DDC controllers shall not be dependent on communications with any on-site or remote PC or master control panel for proper unit operation. The microprocessor shall maintain existing set points and operate stand alone if the unit loses either direct connect or network communications. The microprocessor memory shall be protected from voltage fluctuations as well as any extended power failures. All factory and user set schedules and control points shall be maintained in nonvolatile memory. No settings shall be lost, even during extended power shutdowns.
- C. The DDC control system shall permit starting and stopping of the unit locally or remotely. The control system shall be capable of providing a remote alarm indication. The unit control system shall provide for outside air damper actuation, emergency shutdown, remote heat enable/disable, remote cool enable/disable, heat indication, cool indication, optimal start, and fan operation.
- D. All digital inputs and outputs shall be protected against damage from transients or incorrect voltages. All field wiring shall be terminated at a separate, clearly marked terminal strip.
- E. The DDC controller shall have a built-in time schedule. The schedule shall be programmable from the unit keypad interface. The schedule shall be maintained in nonvolatile memory to insure that it is not lost during a power failure. There shall be one start/stop per day and a separate holiday schedule. The controller shall accept up to sixteen holidays each with up to a 5-day duration. Each unit shall also have the ability to accept a time schedule via BAS network communications.
- F. The keypad interface shall allow convenient navigation and access to all control functions. The unit keypad/display character format shall be 4 lines x 20 characters. All control settings shall be password protected against unauthorized changes. For ease of service, the display format shall be English language readout. Coded formats with look-up tables will not be accepted. The user interaction with the display shall provide the following information as a minimum:
 - G. If the unit is to be programmed with a night setback or setup function, an optional space sensor shall be provided. Space sensors shall be available to support field selectable features. Sensor options shall include:
 - 1. Zone sensor with tenant override switch.
 - 2. Zone sensor with tenant override switch plus heating and cooling set point adjustment. (Space Comfort Control systems only).
 - H. The display shall provide the following information as required by selected unit options:
 - 1. Unit status showing stages or % capacity for cooling, heating, and economizer operation.
 - 2. Supply, return, outdoor, and space air temperature.
 - 3. Duct and building static pressure; the control contractor is responsible for providing and installing sensing tubes.
 - 4. Supply fan and return fan status and airflow verification.
 - 5. Supply and return VFD speed.
 - 6. Outside air damper position and economizer mode.
 - 7. Cooling and heating changeover status.
 - 8. Occupied and unoccupied.
 - 9. Date and time schedules.
 - 10. Up to 10 current alarms and 25 previous alarms with time and date.
 - 11. Dirty filter status.
 - 12. Morning warm-up or night setback status.
 - 13. System operating hours of the SAF, EAF, compressors, economizer, and heat.
 - I. The keypad shall provide the following set points as a minimum as required by selected unit options:
 - 1. Six control modes including off manual, auto, heat/cool, cool only, heat only, and fan only.
 - 2. Four occupancy modes including auto, occupied, unoccupied and bypass (tenant override with adjustable duration).
 - 3. Control changeover based on return air temperature, outdoor air temperature, or space temperature.
 - 4. Primary cooling and heating set point temperature based on supply or space temperature.
 - 5. Night setback and setup space temperature.

6. Cooling and heating control differential (or dead band).
 7. Cooling and heating supply temperature reset options based on one of the following: Return air temperature, outdoor air temperature, space temperature, airflow, or external (1–5 VDC) signal.
 8. Reset schedule temperature.
 9. High supply, low supply, and high return air temperature alarm limits.
 10. Ambient compressor and heat lockout temperatures.
 11. Compressor interstage timers duration.
 12. Duct and building static pressure.
 13. Minimum outdoor airflow reset based on external reset (1–5 VFD) percent of cfm capacity, and fixed outdoor damper position.
 14. Economizer changeover based on enthalpy, dry bulb or network signal.
 15. Current time and date.
 16. Occupied/unoccupied time schedules with allowances for holiday/event dates and duration.
 17. Two types of service modes including timers normal (all time delays) and timers fast (all time delays 20 seconds).
 18. Tenant override time.
- J. Open Communications Protocol—The unit control system shall have the ability to communicate to an independent Building Management System (BMS) through a direct [BACnet ethernet] [BACnet MSTP] [LonTalk] communication connection. The independent BMS system shall have access to [quantity from specification] “read only” variables and [quantity from specification] “read & write” variables. Communications shall not require field mounting of any additional sensors or devices at the unit. [The communications protocol shall be LonMark 3.4 certified under the [Discharge Air] [Space Comfort] functional profiles.]

The BMS system shall be capable of interacting with the individual rooftop controllers in the following ways:

1. Monitor controller inputs, outputs, set points, parameters and alarms.
2. Set controller set points and parameters.
3. Clear alarms.
4. Reset the cooling and heating discharge air temperature set point (VAV and CAV-DTC units).

5. Reset the duct static pressure set point (VAV units).
 6. Set the heat/cool changeover temperature (VAV and CAV-DTC units).
 7. Set the representative zone temperature (CAV-ZTC units).
- K. It will be the responsibility of the Systems Integrating Contractor to integrate the rooftop data into the BMS control logic and interface stations.

2.20 Energy Recovery Wheel

- A. The rooftop unit shall be provided with an AHRI certified rotary wheel air-to-air heat exchanger in a cassette frame complete with seals, drive motor and drive belt. The energy recovery wheel shall be an integral part of the rooftop unit with unitary construction and does not require field assembly. Bolt-on energy recovery units that require field assembly and section to section gasketing and sealing are not acceptable.
- B. The wheel capacity, air pressure drop and effectiveness shall be AHRI certified per AHRI Standard 1060. Thermal performance shall be certified by the manufacturer in accordance with ASHRAE Standard 84, Method of Testing Air-to-Air Heat Exchangers and AHRI Standard 1060, Rating Air-to-Air Heat Exchangers For Energy Recovery Ventilation Equipment.
- C. The rooftop unit shall be designed with a track so the entire energy recovery wheel cassette can slide out from the rooftop unit to facilitate cleaning.
- D. The unit shall have 2" Merv 7 filters for the outdoor air before the wheel to help keep the wheel clean and reduce maintenance. Filter access shall be by a hinged access door with ¼ turn latches.
- E. The wheel shall be wound continuously with one flat and one structured layer in an ideal parallel plate geometry providing laminar flow and minimum pressure drop-to-efficiency ratios. The matrix design shall have channels to reduce cross contamination between the outdoor air and the exhaust air. The layers shall be effectively captured in aluminum and stainless steel segment frames that provide a rigid and self-supporting matrix. All diameter and perimeter seals shall be provided as part of the cassette assembly and shall be factory set. Drive belt(s) of stretch urethane shall be provided for wheel rim drive without the need for external tensioners or adjustment.

- F. The total energy recovery wheel shall be coated with silica gel desiccant permanently bonded without the use of binders or adhesives, which may degrade desiccant performance. The substrate shall be lightweight polymer and shall not degrade nor require additional coatings for application in marine or coastal environments. Coated segments shall be washable with detergent or alkaline coil cleaner and water. Desiccant shall not dissolve nor deliquesce in the presence of water or high humidity.
- G. Wheels shall be provided with removable energy transfer matrix. Wheel frame construction shall be a welded hub, spoke and rim assembly of stainless, plated and/or coated steel and shall be self-supporting without matrix segments in place. Segments shall be removable without the use of tools to facilitate maintenance and cleaning.
- H. Wheel bearings shall be selected to provide an L-10 life in excess of 400,000 hours. Rim shall be continuous rolled stainless steel. Wheels shall be connected to the shaft by means of taper lock hubs.
- I. The exhaust air fan shall be a direct drive SWSI plenum fan. The exhaust fan shall be sized for the airflow requirements per the construction schedule. The unit controller shall control the exhaust fan to maintain building pressure. A VFD shall be provided for the exhaust fan motor or the exhaust fan motor shall be an ECM motor. The rooftop unit shall have single point electrical power connection and shall be ETL listed.
- J. The control of the energy recovery wheel shall be an integral part of the rooftop unit's DDC controller. The DDC controller shall have visibility of the outdoor air temperature, leaving wheel temperature, return air temperature, and exhaust air temperature. These temperatures shall be displayed at the rooftop units DDC controller LCD display. All of these temperatures shall be made available through the BACnet interface.
 1. [Optional] The rooftop unit with the energy recovery wheel shall incorporate the economizer operation. The energy recovery wheel shall have a bypass damper. When the unit is in the economizer mode of operation the energy recovery wheel shall stop and the bypass dampers shall be opened. The outdoor air shall be drawn through the bypass dampers to reduce the pressure drop of the outdoor airstream.
 2. [Optional] The rooftop unit DDC controller shall provide frost control for the energy recovery wheel. When a frost condition is encountered the unit controller shall stop the wheel. When in the frost control mode the wheel shall be jogged periodically and not be allowed to stay in the stationary position.
 3. [Optional] The rooftop unit DDC controller shall provide frost prevention for the energy recovery wheel. The DDC controller will start and stop the energy wheel to prevent the wheel from reaching a frost condition.
 4. [Optional] The rooftop unit DDC controller shall provide a VFD for frost prevention for the energy recovery wheel. The speed of the energy wheel shall be varied to prevent a frost condition on the wheel.



Daikin Applied Training and Development

Now that you have made an investment in modern, efficient Daikin Applied equipment, its care should be a high priority. For training information on all Daikin Applied HVAC products, please visit us at www.DaikinApplied.com and click on Training, or call 540-248-9646 and ask for the Training Department.

Warranty

All Daikin Applied equipment is sold pursuant to its standard terms and conditions of sale, including Limited Product Warranty. Consult your local Daikin Applied representative for warranty details. To find your local Daikin Applied representative, go to www.DaikinApplied.com.

Aftermarket Services

To find your local parts office, visit www.DaikinApplied.com or call 800-37PARTS (800-377-2787). To find your local service office, visit www.DaikinApplied.com or call 800-432-1342.

This document contains the most current product information as of this printing. For the most up-to-date product information, please go to www.DaikinApplied.com.

Products manufactured in an ISO Certified Facility.